

# Livestock housing

Modern management to ensure optimal health and welfare of farm animals



edited by:  
Andres Aland and Thomas Banhazi

## **Livestock housing**





# Livestock housing

**Modern management to ensure  
optimal health and welfare  
of farm animals**

**edited by:  
Andres Aland  
Thomas Banhazi**



*Wageningen Academic  
Publishers*

**Buy a print copy of this book at**

**[www.WageningenAcademic.com/livestockhousing](http://www.WageningenAcademic.com/livestockhousing)**

**ISBN: 978-90-8686-217-7**  
**e-ISBN: 978-90-8686-771-4**  
**DOI: 10.3920/978-90-8686-771-4**

**First published, 2013**

**© Wageningen Academic Publishers**  
**The Netherlands, 2013**

This work is subject to copyright. All rights are reserved, whether the whole or part of the material is concerned. Nothing from this publication may be translated, reproduced, stored in a computerised system or published in any form or in any manner, including electronic, mechanical, reprographic or photographic, without prior written permission from the publisher, Wageningen Academic Publishers, P.O. Box 220, 6700 AE Wageningen, the Netherlands,

[www.WageningenAcademic.com](http://www.WageningenAcademic.com)  
[copyright@WageningenAcademic.com](mailto:copyright@WageningenAcademic.com)

The individual contributions in this publication and any liabilities arising from them remain the responsibility of the authors.

The publisher is not responsible for possible damages, which could be a result of content derived from this publication.







## **Acknowledgements**

The guest editors would like to thank all the people for giving us their valuable help in the preparation process of this book. We especially would like to acknowledge the valuable contributions of numerous reviewers, who ensured that all chapter contributions are of the highest scientific quality while remaining practically relevant. To ensure the impartiality of the rigorous review process their names are kept confidential.



# Table of contents

Acknowledgements	7
Preface	17
<i>Andres Aland and Thomas Banhazi</i>	
<b>Part 1 – Historical introduction</b>	
1. A short history of livestock production	21
<i>J. Hartung</i>	
1.1 Introduction	21
1.2 Livestock production in the ancient times	21
1.3 Livestock production in the Middle Ages	24
1.4 The new age of livestock production	26
1.5 The development of livestock production since the 19 century	28
1.6 Livestock farming today and in future	30
1.7 Conclusions	32
Acknowledgement	32
References	33
<b>Part 2 – General aspects of livestock buildings</b>	
2. A review of the impact of housing on dairy cow behaviour, health and welfare	37
<i>C.J.C. Phillips, B. Beerda, U. Knierim, S. Waiblinger, L. Lidfors, C.C. Krohn, E. Canali, H. Valk, I. Veissier and H. Hopster</i>	
Abstract	37
2.1 Introduction	38
2.2. The effects of housing dairy cows on their opportunities to perform natural behaviour	39
2.3. Health and reproduction in relation to housing	44
2.4. Conclusions	48
Acknowledgements	48
References	48
3. A cow comfort monitoring scheme to increase the milk yield of a dairy farm	55
<i>F.J.C.M. van Eerdenburg, S. Vázquez-Flores, J. Saltijeral-Oaxaca and E.N. Sossidou</i>	
Abstract	55
3.1. Introduction	55
3.2. Materials and methods	56
3.3. Results	56
3.4. Discussion	58
Acknowledgements	60
References	60
Appendix. Score for cow comfort on the dairy farm	63

4. Lying and walking surfaces for cattle, pigs and poultry and their impact on health, behaviour and performance	75
<i>B.J. Lensink, E. Ofner-Schröck, M. Ventorp, P. Zappavigna, J. Flaba, H. Georg and D. Bizeray-Filoche</i>	
Abstract	75
4.1 Introduction	75
4.2 Lying and walking surfaces in cattle	76
4.3. Lying and walking surfaces for pigs	84
4.4. Lying and walking surfaces in poultry	87
4.5. Conclusion	88
References	89
5. Housing of sows during farrowing: a review on pen design, welfare and productivity	93
<i>L.J. Pedersen, J. Malmkvist and H.M.L. Andersen</i>	
Abstract	93
5.1 Background	93
5.2 Welfare consequences of the farrowing crate	94
5.3 Space for sow and piglets in farrowing crates	95
5.4 Piglet mortality in relation to housing	97
5.5 Design of farrowing pens for loose housed sows	100
5.6 Design of farrowing pens for loose housed sows	104
5.7 Conclusion	106
Acknowledgements	106
References	106
<b>Part 3 – Feed, water, bedding and waste management</b>	
6. The impact of feeding and drinking management, and bedding and waste management, on animal health, welfare and performance	115
<i>I. Ekesbo</i>	
Abstract	115
6.1 Introduction	115
6.2 The impact of feeding and drinking management on animal health, welfare and performance	115
6.3 The impact of bedding management and flooring on animal health, welfare and performance	125
6.4 The impact of waste management on animal health, welfare and performance	133
References	140
7. Factors influencing water temperature on farms and the effect of warm drinking water on pig growth	147
<i>T. Banhazi and D. Rutley</i>	
Abstract	147
7.1 Introduction	147
7.2 Materials and methods	148

7.3 Results and discussion	150
7.4 Conclusions	158
Acknowledgements	158
References	158
8. Eco-friendly and efficient management of solid animal manure	161
<i>S.G. Sommer</i>	
Abstract	161
8.1 Introduction	161
8.2 Solid manure characteristics	162
8.3 Transformation of organic matter	163
8.4 Removal of solid manure from animal houses	167
8.5 Solid manure store	171
8.6 Land application of manure	174
8.7 Modelling: methods to reduce greenhouse gas and NH <sub>3</sub> emissions by solid manure management	176
8.8 Discussion	179
8.9 Conclusions	180
References	180
<b>Part 4 – Ventilation and thermal environment</b>	
9. Housing designs that optimize an animal’s thermal environment	185
<i>L.D. Jacobson</i>	
References	187
10. Managing thermal stress in feedlot cattle: environment, animal susceptibility and management options from a US perspective	189
<i>T.M. Brown-Brandl</i>	
Abstract	189
10.1 Introduction	189
10.2 Economic impact of heat stress in feedlot cattle	189
10.3 Environmental conditions	190
10.4 Animal susceptibility	192
10.5 Animal management strategies	196
10.6 Conclusions	203
Disclaimer	203
References	203
11. The impact of ventilation and thermal environment on animal health, welfare and performance	209
<i>S.J. Hoff</i>	
Abstract	209
11.1 Introduction	209
11.2 Brief history of animal housing ventilation	210



11.3 Modern animal housing	212
11.4 Animal housing characteristics	212
11.5 Climate control and environmental stressor mitigation	215
11.6 Specific heat transfer mechanisms	215
11.7 The animal and its thermal environment	220
11.8 Accuracy of estimating heat loss	221
11.9 Summary and conclusions	233
References	234
12. Constructing better piggery buildings by identifying factors contributing to improved thermal control under hot climatic conditions	237
<i>T. Banhazi and D. Rutley</i>	
Abstract	237
12.1. Introduction	237
12.2. Materials and methods	238
12.3 Results	241
12.4 Discussion	250
12.5 Conclusion	254
Acknowledgements	254
References	254
<b>Part 5 – Airborne pollutants</b>	
13. Control of emissions from livestock buildings and the impact of aerial environment on health, welfare and performance of animals – a review	261
<i>G. Gustafsson, S. Nimmermark and K-H. Jeppsson</i>	
Abstract	261
13.1 Introduction	261
13.2 Emissions	267
13.3 Influences of factors in the building environments	267
13.4 Conclusions	274
References	274
14. Controlling the concentrations of airborne pollutants in three different livestock facilities	281
<i>T. Banhazi</i>	
Abstract	281
14.1 Introduction	281
14.2 Material and methods	283
14.3 Results and discussion	287
14.4 Conclusions	292
Acknowledgements	292
References	292

15. Environmental and management effects associated with improved production efficiency in a respiratory disease free pig herd in Australia	297
<i>T. Banhazi</i>	
Abstract	297
15.1 Introduction	297
15.2 Materials and methods	298
15.3 Results	302
15.4 Discussion	308
15.5 Conclusions	311
Acknowledgements	312
References	312
16. A proposed Livestock Burden Index (LBI) for airborne pollutants in livestock buildings	315
<i>J. Seedorf</i>	
Abstract	315
16.1 Introduction	315
16.2 Methodology	317
16.3 Demonstration of application and discussion	320
16.4 Conclusions	324
Acknowledgements	324
References	325
 <b>Part 6 – Hygiene and cleanliness</b>	
17. Aiming at building cleanliness to keep livestock healthy	331
<i>F. Madec</i>	
Abstract	331
17.1 Introduction	331
17.2 Cleanliness and health maintenance	332
17.3 Cleaning-disinfection of livestock buildings	345
17.4 Conclusion	349
References	349
18. Practical evaluation of cleaning methods that could be implemented in livestock buildings	355
<i>T. Banhazi and B. Santhanam</i>	
Abstract	355
18.1 Introduction	355
18.2 Brief literature review	355
18.3 Materials and methods	357
18.4 Results and discussion	362
18.5 Conclusions	373
Acknowledgements	374
References	374

19. Modelling and influencing hygiene conditions in Australian livestock buildings	377
<i>T. Banhazi</i>	
Abstract	377
19.1 Introduction	377
19.2 Materials and methods	379
19.3 Results and discussion	381
19.4 Conclusions	388
Acknowledgements	388
References	389

## **Part 7 – Technological tools for managing livestock facilities**

20. Towards an automatic dairy cattle welfare monitoring	393
<i>V. Poikalainen, E. Kokin, I. Veermäe and J. Praks</i>	
Abstract	393
20.1 Introduction	393
20.2 Concept of automatic cows' welfare evaluation	394
20.3 Essential animal-based parameters for automatic acquisition	395
20.4 Overview of specific modules for lameness estimation	397
20.5 Principal structure of an automatic welfare monitoring system	398
20.6 Concluding remarks	402
Acknowledgements	403
References	403
21. The sound makes the difference: the utility of real time sound analysis for health monitoring in pigs	407
<i>S. Ferrari, M. Silva, V. Exadaktylos, D. Berckmans and M. Guarino</i>	
Abstract	407
21.1 Introduction	407
21.2 Research and achieved results	408
21.3 Conclusions	416
References	416
22. The ease of movement: how automatic gait and posture analysis can contribute to early lameness detection in dairy cattle	419
<i>C. Bahr, A. Van Nuffel, S. Van Weyenberg and D. Berckmans</i>	
Abstract	419
22.1 Introduction – the problem of lameness in dairy production	419
22.2 Available methodologies to analyse the gait of dairy cattle	420
22.3 Two examples to approach automatic detection of lameness in moving dairy cows	421
22.4 The potential of automatic lameness detection systems	427
References	428

23. Lighting for laying hens: the effect of environmental factors on bird behaviour	431
<i>S. Gunnarsson</i>	
Abstract	431
23.1 Introduction	431
23.2 Animals, material and methods	433
23.3 Results	435
23.4 Discussion	437
23.5 Conclusion	438
References	438
24. They have seen the light: 3D light distribution and effects of light intensity on animal welfare in swine husbandry	441
<i>A. Costa, A. Van Brecht, M. Porro, D. Berckmans and M. Guarino</i>	
Abstract	441
24.1 Introduction: lighting standards to meet pig welfare guidelines	441
24.2 Materials and methods	443
24.3 Results and discussion	445
24.4 Conclusions	449
References	451
<b>Part 8 – Occupational and community health aspects of animal production</b>	
25. Challenges to occupational and community health and the environment in animal production and housing: a North American perspective	455
<i>K.J. Donham</i>	
Abstract	455
25.1 Introduction	455
25.2 Types of animal feeding operations and associated housing	456
25.3 Occupational health of swine producers and employees	457
25.4 Prevention	462
25.5 Community health issues	465
25.6 Environmental pollution concerns	470
25.7 Summary	472
References	474
Keyword index	483





## Preface

Sustainability has become an important keyword in connection with modern animal production. There is an expectation from society that animal products must originate from housing environments where both the health and welfare of livestock have neither been impaired nor endangered.

This book is written for all those who seek to optimise the health and welfare conditions of housed animals in commercial practice. We hope that animal scientists, veterinarians, agricultural engineers and other professional scientists in related areas, students and people, who work in different livestock industries, will recognise this comprehensive book as a useful tool for optimising the management of livestock and their environment.

The emphasis throughout the book is on livestock buildings and their key design elements that have to be managed correctly to create environmental conditions that will enhance the health and welfare of livestock as well as the health of farm workers and people living near farming operations. The appropriate design of livestock buildings is a fast-changing and ever-improving professional endeavour, and the stagnation of housing developments could compromise the welfare and the health of the different livestock species.

Contributions to this book have been solicited from specialists from around the world. The following key areas of housing management are reviewed in this book: analysis of prevailing housing systems; feeding and watering of livestock; thermal and aerial environment together with ventilation; light and noise-related issues; controlling emissions; the roles of bedding and waste management; maintaining cleanliness in livestock buildings; use of modern technological tools in the service of livestock management; challenges in regard to the occupational health and safety of farm staff and other closely related issues.

As a unique feature of this book, the main reviews are followed by two to five specific articles presenting information on current research. These articles give experts from around the world an opportunity to report on the results of the most recent studies related to the main reviews. These articles also give more freedom to authors to report on the outcomes of surveys or trials that might fall outside the normal limitations posed by journal or conference articles. Thus the research articles provide a unique forum for leading experts to report on specific aspects of the main topics reviewed in general terms by their peers.

*Andres Aland and Thomas Banhazi*



## **Part 1**

### **Historical introduction**



# 1. A short history of livestock production

*J. Hartung*

*Institute for Animal Hygiene, Welfare and Farm Animal Behaviour, University of Veterinary Medicine Hannover, Foundation, Bünteweg 17P, 30559 Hannover, Germany;  
Joerg.Hartung@tiho-hannover.de*

## 1.1 Introduction

The origin of livestock production dates back about 11,000 years ago (after the last glacial period) when man started to domesticate sheep. This is quite a short period compared to the beginning of the evolution of humanity that dates back about 14 million years ago. This means that humans and their humanlike ancestors survived for millions of years without domestic animals (Reed, 1984) eating plants (that were opportunistically collected) and animals (that were systematically hunted) as the most important food source. With the domestication of animals and the cultivation of plants (somewhat less than 11,000 years ago, also addressed as ‘the Neolithic revolution’), a fundamental change in the development of humanity happened (Benecke, 1994).

Taming and domestication (Mason, 1984) is also the story of a successful symbiosis between animal and humans which presumably started simply by recognising advantages for both. The animal received regularly food and protection from humans, and humans benefited from easier access to the animal and its valuable meat, bones and skins without the need for hunting. Later animals were domesticated for milk, wool, motion power, warfare, sport and prestige (Reed, 1984). During this continuing ‘co-operation’ over thousands of years; both animals and humans changed their living habits and the animals in particular their phenotype, reproductive, growing and production abilities while losing some of their cognitive skills that were not required in captivity any more (Herre und Röhrs, 1990). The authors report that the brain of domesticated animals weighs less (in pigs up to 33%) than that of their wild ancestors. This history of domesticated animals can be divided into several time periods or ‘ages’ of flowing development mostly influenced by humans introducing new technologies in feed production, security, breeding and housing.

## 1.2 Livestock production in the ancient times

The first evidence of a domestic animal (i.e. dog), is dated between 14,000 and 12,000 years ago (Turnbull and Reed, 1974), and the earliest known typical (as we define it in most parts of the world) domestic food animals were sheep somewhat less than 11,000 years ago. We have little, if any, evidence that the cultivation of plants began earlier than 9,000 years ago.

For quite a long period of time, the relation between man and its environment, including plants and animals was a loose coexistence, which became more and more intensive when people settled and were able to increase plant production with increasing crop yield. Different from all other animals, humans did not adapt themselves purely to their environment, but started to ‘use’ the environment to their purposes (Zeuner, 1963). During the early times humans were a pure ‘food-gatherer’ (Palaeolithic period, approx. 14,000 to 12,000 years B.C.). This is the time when



probably the dog became the first animal to live permanently with man helping with guarding, defence and hunting (Turnbull and Reed, 1974). Later (Mesolithic period, approx. 9,000 years B.C.) humans relied more and more on hunting, fishing and collecting shell-fish, grubs, fruit and wild vegetables. This time lasted for several thousand years again during which humans did not influence their natural environment to any noticeable degree (Zeuner, 1963). This changed in the Neolithic period (from about 8,000 to approx. 3,000 years B.C.) and definitively with the advent of the Bronze Age (starting between 3,500 and 2,500 years B.C.) when more systematic farming for food production was developed. These developments took many generations and long time-periods.

The earliest traces of farming are typically found in the Middle East region where ceramics could be dated back to more than 8,000 years B.C. The Bronze Age also started 500 to 1000 years earlier in the Middle East than in North Africa, followed by South, East and Middle Europe. These developments were probably also substantially influenced by the globally changing climate in the post-glacial times to Subboreal (approx. 3,800 to 500 B.C., Benecke, 1994) and Subatlantic (since about 500 B.C. till today) with moderate temperatures and sufficient rainfall allowing settlements to develop with plant and animal production. There are numerous practices known from ancient Egypt in taming and domesticating of various animal species including sheep, goat, cattle (Zeuner, 1963) as the Egyptians left pictures of standard animal husbandry practices (Reed, 1984). Beef cattle were kept indoors with hand feeding and stalls were equipped with drainage for urine (Figure 1.1, after Benecke, 1994).



Figure 1.1. Wooden model of a beef cattle house in ancient Egypt, tomb of Mektire, 11<sup>th</sup> dynasty, 2134-1991 B.C. From: Benecke (1994) (after H.W. Müller, 1970) modified (photo in Department for History of Veterinary Medicine and Domesticated Animals. In: Roemer- und Pelizaeus-Museum Hildesheim, Egypt collection, Germany).

## 1. A short history of livestock production

The high standard of horse husbandry is illustrated in Figure 1.2 showing an ancient Greek stable for 6 horses found in Sicily providing drainage in the floor, individual feed troughs, slits for halter-straps and ventilation openings above the troughs (from Klimmer, 1924). Evidently, housing standards for horses in ancient Greece were not much different from what we provide for horses today.

During the time of the Roman Iron Age and the migration period (1<sup>st</sup> to 6<sup>th</sup> century AD) food supply in Middle Europe and South Scandinavia was predominantly based on crop and animal production (Benecke, 1994). Reports and archaeological findings indicate that the dominating farmed animal was cattle (56%) followed by pig (28%) and sheep/goat (16%) (Benecke, 1994). The distribution of species on the farms was dependent on region and living conditions. Benecke (1994) reports that unlike in the inland areas; sheep was dominating the Dutch coastal regions. His explanation is that sheep were protected by the salty and dry soil conditions from contracting sheep liver fluke because these conditions hampered significantly the development of *Galba truncatula*, the alternate host of sheep liver fluke, compared to the inland sweet water regions. Thus, sheep thrived in the coastal areas.

In Germanic settlements along the River Weser reconstructions of farm buildings gave indication about the development of farms and the number of housed animals in that region (Benecke, 1994, cit. Ennen and Janssen, 1979). While in the 1<sup>st</sup> century B.C., five farms with a grand total of 98 cattle (in 54 in-house pens) were identified; these numbers increased in the 1<sup>st</sup> century AD to 8 farms with 176 cattle (in 98 pens). In the 2<sup>nd</sup> century numbers further increased to 19 farms with 377 cattle (in 218 pens) and in the 3<sup>rd</sup> century to 19 farms with 443 cattle in 267 pens. With increasing animal farming the importance of hunting decreased considerably in the regions around the North and Baltic Sea. From bone findings, it is known that hunting of wild animals contributed only 0.5% of all nutritional intakes together with fish that played a considerable role in the diet of humans especially in coastal regions. However, inland the proportion of hunted animals in the diet could rise to about 5% depending on region (Benecke, 1994).

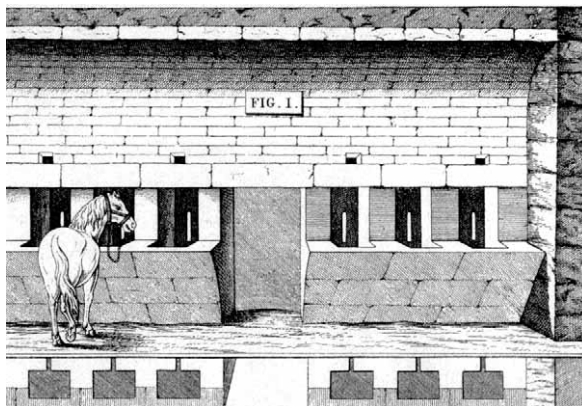

Figure 1.2. Horse stable in Sicily with drains in the floor, individual feed troughs, slits for halter-straps and ventilation openings above the troughs (from Klimmer, 1924).

Interestingly prices reported from that time showed that chicken were the most valuable livestock. Under the rule of Emperor Diocletian (245-316 AD) a pair of chicken used to cost around 60 denarii, a pair of pigeons 24, a pound of pork 12 to 24, while beef, mutton and goat were the cheapest meat with about 8 denarii per pound (Benecke, 1994). The high value of chicken may have been also the reason for relatively large flock sizes.

The Roman writers Varro and Columella (1<sup>st</sup> century AD) (in Benecke, 1994) described poultry houses for 200 birds. The houses consisted of three different parts, which were connected by a service room for the animal attendants. The houses were illuminated by natural light through wooden windows with willow branch nettings and equipped with elevated perches and nests made of fibre baskets mounted along the walls with landing spaces in front of the nests. Openings in the wall allowed birds to use the outdoor area, which was protected by a wall and a net against predators 'by foot' and from the air. Columella recommended the provision of sand and ash for dust bathing in some part of these areas protected by a roof. He gave advice to farmers, urging them to provide sufficient space for animals like sheep, goat, mare and foal when kept indoors and protect them from cold in winter. He also advised ancient livestock producers to build stables with perforated floors for draining urine and faeces, so conditions in livestock buildings can be kept dry.

Pigs were kept predominantly outdoors most of the year (Benecke, 2003). Shelters were used only in wintertime or for sensitive animals like pregnant sows. Columella (in Benecke, 2003) reports that pregnant sows were kept indoors in separate pens made of wood. The walls were 1.2 m high. A bar at the entrance of the pen was high enough to allow the sow to walk in and out, e.g. for foraging while the piglets could not go across the bar. Similar systems are recently discussed in modern animal production in order to improve animal welfare and avoid suffering of sows in the farrowing crates used typically on modern farms. It is interesting to note that thousands of years ago the advice given to farmers were quite similar to the advice given to modern livestock producers.

### **1.3 Livestock production in the Middle Ages**

The husbandry and management systems used in Europe during the Middle Age did not differ much from the earlier centuries. Pasture farming continued (Benecke *et al.*, 2003). Cattle, sheep, pigs and other livestock were kept predominantly outdoors and had to forage for food on the fields, fallow land, meadows or in the forest close to the villages. However, changes happened gradually and parallel to political, sociological and technical developments. In the early Middle Age (6<sup>th</sup> to 11<sup>th</sup> century) large proportion of the population were engaged in agriculture. Around 1500 AD, it was still 80% of the population (Falkenberg and Hammer, 2006) that were directly involved in food production.

Christianisation progressed and the erection of feudal systems supported the spread of agriculture. However, these forces also supported the development of towns and trade (Falkenberg and Hammer, 2006). More and more land was cultivated. Between the 8<sup>th</sup> and the 13<sup>th</sup> century, the area of arable land doubled from about 3 to 5% to about 6 to 10% (Poprawka, U., personal communication). By abandoning 'two-field' use of the land (i.e. simple rotation between fallow and

## 1. A short history of livestock production

cultivated portions of the land) and the introducing the so called three-field rotation; the amount of fallow land was reduced from 50 to 33% and the efficiency of food production was dramatically increased (Poprawka, U., personal communication). Numerous technical improvements were also introduced like iron horse shoes, which enabled the horses to pull carriages and loads 4-times heavier than before (Poprawka, U., personal communication). The village blacksmiths became important professionals and their skills and knowledge formed later the basis of horse medicine (Giese, 1994). As an example, the University of Veterinary Medicine in Hannover was founded in 1778 as 'Rossarzneischule' (school for horse medicine) by King George III, King of Great Britain and Elector of Hannover. Many more inventions were introduced in practice like iron-enforced wheels for carriages, iron armoured ploughs which all helped to increase the efficiency of agricultural production. As a result, between the 7<sup>th</sup> and the 14<sup>th</sup> century the population in Western Europe rose from about 21 to about 71 million (Falkenberg and Hammer, 2006). Unfortunately, this development was decelerated by some hunger crises and plagues waves (Black Death).

The consumption of meat enjoyed increasing popularity in the Middle Ages. There are reports from France and Sicily providing average consumption figures per person and year. The highest consumption was reported for a peer in the province of Auvergne consuming about 100 kg meat. In the town of Tours the meat consumption reached 43 kg while in Carpentras the consumption was with 23 kg only half (Falkenberg and Hammer, 2006). Even in Sicily (where fish also contributed significantly to the menu) as much as 15 to 20 kg of meat was consumed per person (Falkenberg and Hammer, 2006). These figures are very significant events by modern standards.

In the course of the centuries; pork became more and more popular in many parts of Central Europe while in the North Sea and Baltic region sheep and cattle were dominating the menus (Benecke, 2003; Falkenberg and Hammer, 2006). For example, it has been documented that Emperor Charles the Great (742-814) gave order that pork and pork products should always be available on his farms (Brandsch, 1990) and the Earl of Angoulene in France apparently offered 120 pigs (roasted pork) to his guests during a banquet (Falkenberg and Hammer, 2006). From pig skeletons found in regions from the Baltic Sea, Pomerania, central Poland and Silesia it can be concluded that in the High Middle Ages (11<sup>th</sup> to 13<sup>th</sup> century) about 50% of the domesticated animals on farms were pigs (Benecke, 1994). However, these pigs looked quite different from our pig breeds today and resembled much their wild ancestors. Usually swineherds guarded the pigs of a village. Particularly in autumn, the pigs were driven to nearby forests and fed with wild acorns. A famous painting of Albrecht Dürer shows a swineherd with his dogs and the horn which he blows in the evening to gather the herd before returning to the village (Figure 1.3). These swineherds were also responsible for maintaining the health of the pigs (Falkenberg and Hammer, 2006). This might have been the starting point of 'swine veterinary medicine'. In some regions, the pigs carried bells so they could be located easily and the noise of the bells would also protect them from predators (Rinesch, 2001).

Housing of animals in the Middle Ages was mostly reserved for farrowing sows or for other livestock in wintertime when feed supply was limited outdoors. Regularly in autumn, numerous animals were slaughtered (1) to ensure sufficient food supply for the family and (2) to reduce the number of animals, which had to be housed and fed during the cold season. However, with



Figure 1.3. *The prodigal son as swineherd* (Albrecht Dürer 1471-1528).

the growing demand for meat and the increasing crop production, the space for pigs and cattle foraging in fields and forests became limited and animals were increasingly kept indoors over longer periods (Falkenberg and Hammer, 2006). It was reported that herds of 150 pigs were kept on some farms (Czerwinski, 1964, in Falkenberg and Hammer, 2006). However, pigs were not only kept on farms but also in towns where they were used as waste converters and many bakers for example kept pigs in the backyard and fed them with the leftover of wheat, flour and bran (Falkenberg and Hammer, 2006).

#### 1.4 The new age of livestock production

Animal farming did not change very much between the end of the Middle Ages and the 17<sup>th</sup> century. Its development was always closely related to the progress and productivity of plants production. Three-field rotation continued as the most important production system. Only in some areas like Silesia and Saxony four-field and five-field production systems were introduced in order to reduce the amount of fallow land (Seidl, 1995). Consequently, less pasture was available for livestock production and farm animals were pushed back in favour of cultivation of cereals, beets, cabbage and other fruits (Seidl, 1995). There was no specific animal feed production or indoor housing during the summer. Animals were fed according to grazing rights in summer



and the farmers tried to nurse the livestock through the winter on rather poor diets (Seidl, 1995) such as foliage and small twigs. The low prices of meat compared to cereals did not provide any incentive to invest in the intensification of livestock production (Seidl, 1995). Comberg (1984) gives an example of the development and relation of the prices for rye and meat (relative figures are shown) between 1740 and 1806 in the town of Berlin (Table 1.1).

The transformation of animal farming towards higher productivity happened only when crop rotation was introduced in agriculture, starting first in England (Seidl, 1995). This system of growing a different crop on the field every year, used the land more efficiently and opened the way for systematic fodder production or specific pastures for grazing (Seidl, 1995). Depending on the farm management and the quality of the land; animals could be kept indoors or on specially prepared pastures in summer. In the United Kingdom, Adam Smith (1776, in Comberg, 1984) was quoted saying: ‘a grain field of moderate fruitfulness produces a larger amount of food for the population than the best pasture of the same size.’ There were even proposals to abandon animal farming completely which was however not possible because farm animals were desperately needed as draught animals and their manure as fertilizer in crop production (Comberg, 1984). All these discussions and developments opened the way for non-grazing (intensive) animal production systems. Albrecht Thaer (1752-1828), one of the most influential advocates (Klein, 1969) of non-grazing animal production systems gave five advantageous reasons (Seidl, 1995):

1. reduce the demand for land as opposed to pastoral farming;
2. the manure can be prepared and stored indoor and than can be used in a directed way as fertilizer;
3. the cultivation of fodder in the system of crop rotation avoids idle fallow land;
4. livestock can be provided with sufficient and nutritive feed throughout the year;
5. animal health is not negatively affected when the animals have temporarily access to a free-range area (paddock).

However, others criticised the so-called ‘all-year non-grazing systems.’ Walz (1867, in Seidl, 1995) recommends to rotate grazing on different pastures and he points out that cows gave more milk when kept on meadows. Settegast (1878, in Seidl, 1995) refers to the situation in England where indoor keeping of cows during summer was not successful. Interestingly he calls for scientific research to clarify the relative excellence of grazing as compared to non-grazing systems.

*Table 1.1. Comparison of prices for rye and meat between 1740 and 1806.<sup>1</sup>*

Year	Price of rye	Price of meat
1740	100	100
1780	125	120
1790	120	124
1806	300	254

<sup>1</sup> Figures are related to prices in 1740 = 100. No currency given, relative numbers.

## **1.5 The development of livestock production since the 19<sup>th</sup> century**

With the introduction of modern science in agriculture from the middle of the 18<sup>th</sup> century, scientists started to systematically explore opportunities for further production increases in both plant and animal production. This was necessary because of the increasing demand for food for an increasingly urbanised European population. The scientists tried to understand the relationships between soil, plant, weather and fertilisation and recognised the importance of good nutrition and appropriate housing for farmed animals. Examples are Albrecht Daniel Thaer (1752-1828) or Adam Smith (1723-1790). Johann Christian Polycarp Erxleben (1744-1777), Professor at the University of Göttingen, wrote about the importance of adequate stocking densities. He argued that livestock species should not be housed in primitive shelters. He recognised that in overstocked animal houses the air is polluted with high concentrations of noxious gases generated by animals and the manure. He argued that it is better to have barns with high ceilings and with openings for ventilation. This may decrease the temperature in the house, which is not detrimental for sheep and cattle, but will improve air quality. He also recommended that animals need to be provided with day light in barns which improves their health and welfare (citations from Comberg, 1984). These recommendations (while not earth-shattering by current standards) clearly demonstrate that agriculture scientists tried to apply the rules of natural science in animal farming.

The 18<sup>th</sup> century was the time of devastating waves of rinderpest in Europe. Around the year 1765 millions of cattle died, for example in the Netherlands 395,000, in the East Friesian region 116,277 and in Denmark 255,000 (Nussbag, 1954). Between 1754 and 1755 about 70,000 cattle died only in the English counties of Nottingham and Cheshire. The government decided to kill all sick and suspected animals – 80,000 in total. This drastic measure stopped the disease and the infectious agent died out for a long period in the United Kingdom (Nussbag, 1954). This was the origin of the eradication policy for similar plagues even today. The large plague put veterinary medicine in the focus and many Veterinary Schools were founded across Europe, e.g. in Lyon 1761, Alfort (close to Paris) 1764, Vienna 1765, Hannover 1778 and London (Royal Veterinary College) in 1791.

In the following years, the number of livestock rose continuously. In 1800 about 10 million cattle were counted in the area of Germany (German Empire). This number rose in 1913 to nearly 21 million, and the pig population increased from 3.8 to 25 million during this period (Comberg, 1984). In 1950 the numbers of cattle and pigs on the area of then West-Germany reached about 11 million and nearly 12 million, respectively. In the following years livestock production fundamentally changed with the advent of intensification. The number of dairy cattle decreased to today 3.5 million with very high milk production and pig and poultry production increased. This steep increase of pig production is demonstrated as an example in Figure 1.4 showing the number of pigs kept in a district of only 800 km<sup>2</sup> in the northwest of Germany which today belongs to the most productive and prosperous rural areas in Germany.

This 'pig curve' mirrors the political and sociological developments over a period of 150 years, indicating the steady increase from the second half of the 19<sup>th</sup> century. The boost in pig numbers around the 1890's coincides with a strong boost of economy. The slight depression in pig numbers

## 1. A short history of livestock production

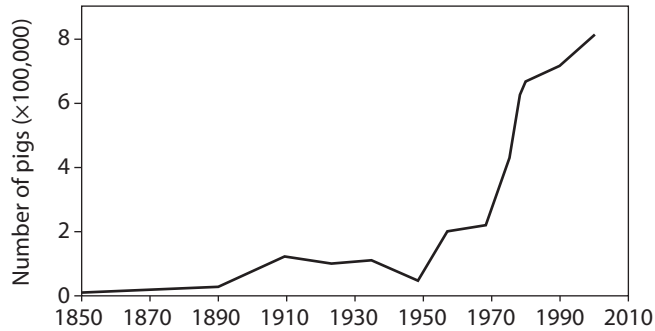

Figure 1.4. Development of pig production in a district in the northwest of Germany, since 1852 (area approx. 800 km<sup>2</sup>) (after Klön and Windhorst, 2001).

caused by the first world war and the deep recess after the second world war followed by a steep recovery can all be seen on the graph. The strongest increase can be observed from about 1970 when new and intensive husbandry and production methods were introduced, slowing down in recent years (Bäuerle and Tamásy, 2012). This is also reflected in the world meat market which rose by a factor of four between 1961 and 2005 from 60 million tons to 240 and expecting a steady increase in the future ([www.fao.org](http://www.fao.org)). The same applies to poultry production (Figure 1.5) which came from a low level and rose by a factor of more than ten. Poultry meat showed the highest growth during the last 35 years (Windhorst, 2006). At the same time the number of poultry farmers dropped from nearly 3.5 million to a few 100,000, e.g. in Germany (Klön and Windhorst, 2001). Actual figures show that the shrinking of the number of farms is continuing. Between 2007 and 2010 about 22,300 German farmers gave up (ADR, 2012) most of them renting out their land to bigger farms. In spite of shrinking farm numbers in Europe, the number of farm animals reached a new world wide high with 68.8 billion poultry, 11.8 billion ruminants (cattle, sheep, goats) and 1.5 billion pigs in 2010<sup>1</sup>.

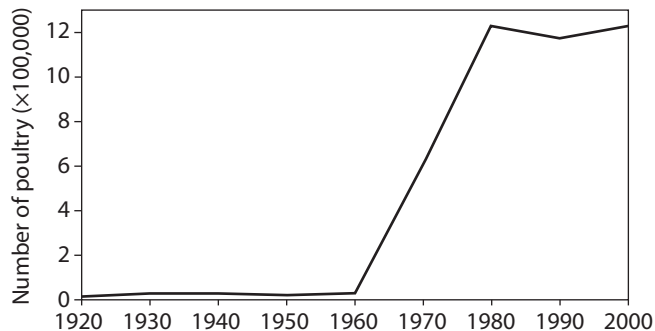

Figure 1.5. Development of poultry production in one district in Northwest Germany, since 1920 (area ~800 km<sup>2</sup>) (after Klön and Windhorst, 2001).

<sup>1</sup> [www.statista.com/statistics/182114/global-stock-of-domestic-and-farm-animals-2010](http://www.statista.com/statistics/182114/global-stock-of-domestic-and-farm-animals-2010).



## **1.6 Livestock farming today and in future**

The development of animal production in recent decades can be characterised by intensification and specialisation (Hartung, 2000).

Intensification means indoor animal housing all year round ('non-grazing'), high animal densities, a high degree of mechanisation and automation (e.g. in feeding, water supply, manure removal and ventilation), a low labour requirement and often a small air volume in relation to the number of animals in the housing unit. In the European Agreement on the Protection of Animals in Animal Farming this is defined as follows: 'modern intensive animal farming systems are systems in which mainly technical facilities are used that are primarily operated automatically and in which the animals largely depend on the care and supply of man.'

Specialisation means that only one animal species, specially bred for the purpose, is kept in specialised buildings on the farm. The consumers often have problems recognizing this animal production as the general population still largely associate farming with traditional concepts of a farm on which several animal species, from dairy cows to hens, are kept. The catchword 'animal factories' then spreads quickly and complaints are voiced that animals are simply considered as 'animal machines' (Harrison, 1964) under purely commercial conditions. In general terms, 'specialised intensive animal husbandry' is often interpreted as 'mass animal farming' with all its negative connotations. On the other hand, consumers readily take advantage of the economic benefits created by recent developments in animal farming as in some parts of continental Europe, one kg of pork can be purchased ready for just a few Euros.

In some regions of Europe, like the North-West Germany, southern parts of the Netherlands and in the north of France this intensive animal production is so concentrated that it can cause environmental pollution via odours, ammonia, dust, micro-organisms and bio-aerosol emissions, triggering complaints from neighbouring residents (Hartung and Wathes, 2001).

Another characteristic of this intensive animal production is that ever fewer persons are employed in this sector. Therefore, the complex work procedures used in modern livestock production are not known or increasingly misunderstood by the general population and thus animal production practices are losing popular support. As an example, in the year 1900 an average German household had to spend about 57% of its income on food, but currently food expenditure has been reduced to 14% (Statista, 2012). For the first time in human history, Europeans do not need to worry about sufficient food supply. The concerns of the public are increasingly directed to other subjects like the welfare of the animals, the safety of the food products and environmental pollution. For example, recent reports demonstrate that significant quantities of antibiotics are used to aid animal production in many European countries (Grave *et al.*, 2010). An actual survey unveiled that in 2011 about 1,734 tons of antibiotics were applied in animal farming in Germany ([www.bvl.bund.de](http://www.bvl.bund.de)). Thus, consumers are calling for a sustainable livestock production that will enhance animal welfare, food safety without jeopardising environmental sustainability (Hartung, 2000).

## 1. A short history of livestock production

Originally, the term ‘sustainability’ was used to mean a management principle in forestry, that ensured that the volume of timber harvested would not exceed the volume that can be re-grown on a renewable basis (Altieri, 1994). In principle, sustainability can also be applied to animal farming. However, that also means that the livestock producers have to meet the demands and expectations of the consumer and the society. It is no longer enough to offer sufficient and cheap food. Ethical aspects of livestock farming gained more and more attention. To reconcile the ‘split’ between livestock producers and the society is an important task for agriculture professionals currently.

The different and interconnected aspects of modern animal production are represented in Figure 1.6. It is quite clear that modern animal production practices should improve animal health and welfare. The presently still widely used ‘man-made production environments’ (Wathes, 1993) must be replaced by systems which meet the requirements of the animals and satisfy their behavioural needs. When looking back in history, it is astonishing to see that the legislation implemented by the European Union to protect the welfare of laying hens in intensive production actually resemble closely the recommendations that were written up in the first century AD (see Columella).

Animal production will be successful in the future and will succeed in reconciling the different requirements and social demands placed upon it, such as the maintenance of a high level of animal health and welfare, consumer safety and environmental protection. Loose housing systems for cows and free range systems for laying hens are being introduced. Unrestricted farrowing crates for sows are under investigation in several countries (Fels *et al.*, 2012). The future of animal production in Europe will depend very much on the cooperation between all parties involved such as farmers, agricultural scientists, engineers, veterinarians, retailers and consumers. When these parties will develop an understanding of each other and the important economical constraints of

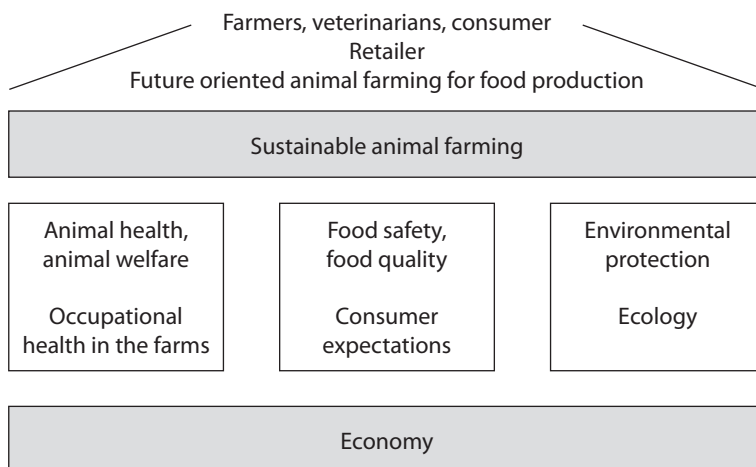

Figure 1.6. Scheme of a future oriented sustainable livestock production (after Hartung, 2012).

animal farming (which forms the base of any production), then collaboration will deliver benefits to farmers, consumers, the environment and will improve the well-being of farmed animals.

## **1.7 Conclusions**

This chapter reviewed the developments of animal farming from the ancient days until present times, mainly concentrating on the Central European region. It has been established that humanity survived for many millennia by hunting and gathering food without farmed animals. Only with the beginning of domestication some 14,000 years ago animals and man started to live in closer association. First sheep and dogs were domesticated. With progress in systematic plant selection settlements were founded and more animal species were domesticated. Horses for transport and warfare became indispensable parts of human life. The growing human population was nourished increasingly by cereals, which could be harvested and stored. Eating meat was typical for aristocrats and rich people. For a long time farm animals were insufficiently fed and poorly housed particularly in winter, which reduced their efficiency and importance for the survival of people. Only with the introduction of new management techniques like crop rotation and organised harvest, the storage of fodder became a possibility. The availability of food and feed all over the year formed the basis of the growth of the human population. The number of farm animals increased continuously over the centuries to feed the workers in the factories of the industrialised world. With increasing income, the consumption of meat also increased. The highest increase in farmed animals occurred between 1950s and 1980s coinciding with the advent of intensive livestock production. Particularly pig and poultry production became independent of the surrounding land because of feed imports from other parts of the world. Large farming enterprises with many 1000 of cattle, 10,000 of pigs and 100,000 of poultry became the norm in animal production. This intensification of production made meat, milk and eggs so cheap that everybody in Europe could afford it easily. The cost of nutrition for an average German household dropped from about 57% in 1900 to about 14% today. An increasing number of people feel that these low prices are achieved on the expense of the welfare of the animals, the quality of the environment and by using significant quantities antibiotics in order to keep animals healthy in large numbers.

In order to feed a fast growing world population it is necessary to find the balance and ensure a sustainable future for livestock production which will guarantee high standard of welfare for animals, safe food for humanity, a clean environment for all to enjoy and sufficient income for the livestock producer.

## **Acknowledgement**

The author thanks Prof. Dr. J. Schäffer, Department for History of Veterinary Medicine and Domesticated Animals of the University of Veterinary Medicine Hannover for his help providing historical pictures and Prof. Dr. Thomas Banhazi for his careful review and help with the manuscript.

### References

- ADR-Informationen, 2012. Nr. 38/12 Arbeitsgemeinschaft Deutscher Rinderzüchter e.V., Bonn, Germany.
- Altieri, M.A., 1994. Biodiversity and pest management in agroecosystems. Hayworth Press, New York, NY, USA.
- Bäuerle, H. and Tamásy, C., 2012. Regionale Konzentrationen der Nutztierhaltung in Deutschland. Mitteilungen – issue 79. Institut für Strukturforchung und Planung in agrarischen Intensivgebieten (ISPA). Universität Vechta., Vechta, Germany.
- Benecke, N., 1994. Der Mensch und seine Haustiere. Konrad Theiss Verlag GmbH und Co., Stuttgart, Germany.
- Benecke, N., 2003. Haustierhaltung. In: Benecke, N., Donat, P., Gringmuth-Dallmer, E. and Willerding, U. (eds.) Frühgeschichte der Landwirtschaft in Deutschland. Beier & Beran. Archäologische Fachliteratur, Langenweißbach, Germany.
- Benecke, N., Donat, P., Gringmuth-Dallmer, E., Willerding, U. (eds.), 2003. Frühgeschichte der Landwirtschaft in Deutschland. Beier & Beran. Archäologische Fachliteratur, Langenweißbach, Germany.
- Brandsch, H., 1990. Die Landgüterordnung und seine Haustiere. Theiss-Verlag, Stuttgart, Germany.
- Czerwinski, H.J., 1964. Zur Entwicklung der Landwirtschaft des Kreises Wismar, 1550-1970. Diss. Universität Rostock, Rostock, Germany.
- Columella, 1972. De re rustica. Aus dem Lateinischen übersetzt, eingeführt und erläutert von K. Ahrens. Schriften zur Geschichte und Kultur der Antike 4. Berlin, Germany.
- Comberg, G., 1984. Die deutsche Tierzucht im 19. und 20. Jahrhundert. Verlag Eugen Ulmer, Stuttgart, Germany.
- Ennen, E. and Janssen, W., 1979. Deutsche Agrargeschichte: Vom Neolithikum bis zur Schwelle des Industriezeitalters. Steiner, Wiesbaden, Germany.
- Falkenberg, H. and Hammer, H., 2006. Zur Geschichte und Kultur der Schweinezucht und Haltung. 2. Mitteilung: Schweinezucht und -haltung in Europa im Mittelalter. Züchtungskunde 78(4): 291-308.
- Fels, M., Hoy, S. and Hartung, J., 2012. Influence of origin litter on social rank, argonistic behaviour and growth performance of piglets after weaning. Applied Animal Behaviour Science 139: 225-232.
- Giese, C., 1994. Mensch und Tier im Mittelalter. Tierärztliche Praxis 22: 103-110.
- Grave, K., Torren-Edo, J. and Mackay, D., 2010. Comparison of the sales of veterinary antibacterial agents between 10 European countries. Journal of Antimicrobial Chemotherapy 65: 2037-2040.
- Harrison, R., 1964. Animal machines. The new factory farming industry. Vincent Stuart Publishers, London, UK.
- Hartung, J., 2000. Sustainable animal production/Nachhaltige Tierproduktion in the 21. Century. In: Proc. 7. Forum Animal Nutrition, BASF Aktiengesellschaft, Ludwigshafen, Germany, pp. 16-38.
- Hartung, J. and Wathes, C.M., 2001. Livestock farming and the environment, Sonderheft 226, Landbauforschung Völkenrode, Braunschweig, Germany, 56 pp.
- Hartung, J., 2012. Tierwohl – ein Teil der Nachhaltigkeit in der Nutztierhaltung? Proceedings 'Nachhaltigkeitsindikatoren für die Landwirtschaft: Bestimmung und Eignung' – Schwerpunkt Tierische Erzeugung, 124. VDLUFA-Kongress, Passau, 18.-21.09.12, VDLUFA-Schriftenreihe 68: 97-108.
- Herre, W. and Röhrs, M., 1990. Haustiere – zoologisch gesehen. 2. Auflage. Gustav Fischer Verlag, Stuttgart, Germany.
- Klein, E., 1969. Geschichte der deutschen Landwirtschaft. Verlag Eugen Ulmer, Stuttgart, Germany.
- Klimmer, M., 1924. Gesundheitspflege der landwirtschaftlichen Nutztiere. 4. Auflage. Paul Parey, Berlin, Germany.

## J. Hartung

- Klon, W. and Windhorst, H.W., 2001. Das agrarische Intensivgebiet Süddoldenburg. Entwicklungen. Strukturen. Probleme. Perspektiven. Vechnaer Materialien zum Geographieunterricht (VMG), issue 2. 3<sup>rd</sup> new edition. Vechna, Germany.
- Mason, I.L., 1984. Evolution of domesticated animals. Longman, New York, NY, USA, p. 452.
- Müller, H.W., 1970. Ägyptische Kunst. Frankfurt am Main, Germany.
- Nussbag, W., 1954. Hygiene der Haustiere. S. Hirzel Verlag, Leipzig, Germany.
- Reed, C.A., 1984. The beginnings of animal domestication. In: Mason, I.L. (ed.) Evolution of domesticated animals. Longman, New York, NY, USA, p. 1-6.
- Rinesch, P., 2001. Beiträge zu den Haltungsbedingungen von Nutztieren im süddeutsch-österreichischen Raum des Spätmittelalters. Schweizer Archiv für Tierheilkunde 143: 11-18.
- Seidl, A., 1995. Deutsche Agrargeschichte. SFW. Band 3. Fachhochschule Weihenstephan, Freising, Germany.
- Settegest, H., 1878. Die Thierzucht, Band 1 und 2. 4. Auflage. Korn, Breslau, Germany.
- Smith, A., 1776. An inquiry into the nature and causes of the wealth of natives. 2<sup>nd</sup> volume. London, UK.
- Statista, 2012. Statistisches Bundesamt, private Haushalte im Inland 1900-2010, Deutschland.
- Turnbull, P.F. and Reed, C.A., 1974. The fauna from the terminal Pleistocene of Palegawra cave, a Zarzian occupation site in northeastern Iraq. Fieldiana Anthropology 63(3): 81-146.
- Walz, G., 1867. Landwirtschaftliche Betriebslehre. Cotta Verlag, Stuttgart, Germany.
- Wathes, C.M., 1993. Animals in man's environment: a question of interest. In: Proc. 4<sup>th</sup> Internat. Symp., University of Warwick, UK, 6-9 July 1993, Suppl. ASAE, 1255-1266.
- Zeuner, F.E., 1963. A history of domesticated animals. Hutchinson & Co., London, UK.

## **Part 2**

### **General aspects of livestock buildings**



## 2. A review of the impact of housing on dairy cow behaviour, health and welfare

C.J.C. Phillips<sup>1</sup>, B. Beerda<sup>2</sup>, U. Knierim<sup>3</sup>, S. Waiblinger<sup>4</sup>, L. Lidfors<sup>5</sup>, C.C. Krohn<sup>6</sup>, E. Canali<sup>7</sup>, H. Valk<sup>8</sup>, I. Veissier<sup>9</sup> and H. Hopster<sup>10</sup>

Centre for Animal Welfare and Ethics, School of Veterinary Science, University of Queensland, Gatton 4343, QLD, Australia; <sup>2</sup>Adaptation Physiology Group, Department of Animal Sciences, Wageningen University, P.O. Box 338, 6700 AH Wageningen, the Netherlands; <sup>3</sup>Farm Animal Behaviour and Husbandry Section, University of Kassel, Nordbahnhofstraße 1a, 37213 Witzenhausen, Germany; <sup>4</sup>Institute of Animal Husbandry and Animal Welfare, University of Veterinary Medicine, Veterinärplatz 1, 1210 Wien, Austria; <sup>5</sup>Department of Animal Environment and Health, Swedish University of Agricultural Sciences, P.O. Box 234, 532 23 Skara, Sweden; <sup>6</sup>Department of Animal Health and Welfare, Danish Institute of Agricultural Sciences, Research Centre Foulum, P.O. Box 50, 8830 Tjele, Denmark; <sup>7</sup>Istituto di Zootecnica, Facoltà di Medicina Veterinaria, Università degli Studi di Milano, Via Celoria 10, 20133 Milan, Italy; <sup>8</sup>Division ID TNO Animal Nutrition, Institute for Animal Science and Health, P.O. Box 65, 8233 AB Lelystad, the Netherlands; <sup>9</sup>INRA URH-ACS Centre de Clermont-Ferrand/Theix, 63122 Saint-Genes-Champanelle, France; <sup>10</sup>Animal Sciences Group (ASG), Wageningen UR Livestock Research, Edelhertweg 15, 8219 PH Lelystad, the Netherlands; [c.phillips@uq.edu.au](mailto:c.phillips@uq.edu.au)

### Abstract

Housing dairy cows offers the possibility to control many aspects of their lives, including accurate rationing, which is especially important for high yielding cows, and rapid health care. In addition, some parasitic diseases are largely controlled by removing cows from pasture. However, housing cows is associated with an increased prevalence of several serious diseases, e.g. mastitis and lameness. In housing systems cows can less readily synchronise their behaviour with other cows, maintain adequate personal space and express oestrus behaviour, compared to cows at pasture. Soft ground and space at pasture facilitate natural locomotion, lying down/standing up motions and resting, without the behavioural abnormalities that may occur inside cubicle houses. Although an inability to perform natural behaviour often impairs health and welfare in housed cows, this is not always the case, and so the precise welfare implications of housing with regards to some of the different types of (natural) behaviour remain tentative. The present findings suggest that dairy cow production based on intensively housed cows is less desirable from the perspective of animal behaviour and health, and hence welfare. However, increasingly larger and more productive dairy herds are utilising intensive housing systems because they facilitate mechanised management systems and a reduction in labour requirements, and the negative implications for welfare are worthy of detailed consideration.

**Keywords:** buildings, cattle, dairy farming systems, grazing, housing



## 2.1 Introduction

For centuries dairy cows were kept close to, or in, houses to produce milk for the occupants and for sale nearby. In the 19<sup>th</sup> and early 20<sup>th</sup> century improved opportunities for milk transport and processing allowed dairy cows in developed parts of the world to be predominantly kept on pastureland away from cities. A temperate climate and moderate to high rainfall areas were favoured so that grass could be easily grown without the need to conserve feed, except for some hay for feeding in winter when the grass growth declined. In the latter part of the 20<sup>th</sup> century the development of improved techniques for harvesting and conserving grass in the form of silage, together with increased availability of high quality supplements and increasing demand for milk and milk products gave farmers the incentive to keep cows indoors for longer periods. Concurrently, the introduction of milking parlours, which enabled farmers to keep their cows in loose housing systems instead of tied in stalls, facilitated the development of housing systems in which cattle could be mechanically fed. These developments provided more flexibility in their feeding, better health management and control over productivity; and they were part of the intensification of the dairy farming industry, which paralleled that in the pig and poultry industries at this time.

In the early stages of intensification cows were mainly kept tied in stalls, but this has rapidly declined in most large scale systems, in favour of loose housing of cows indoors. The provision of a place for cows to lie down in loose housing can either be in cubicles (free stalls) or deep straw bedding. The latter is preferable for the cows' welfare because of better comfort, health and hygiene for the cows, as evidenced by lower mortality (odds ratios: loose housing with deep bedding 0.79, cubicles 1.00 and tie stalls 1.04, Thomsen *et al.*, 2006). Tie stalls have been associated with many welfare problems: leg injuries, stiffness in rising, collisions whilst lying down and reluctance to move lying position regularly, trampled teats, stress caused by the use of electronic cow trainers and performance of stereotypic behaviours, usually tongue rolling. However, as they require more labour per cow for feeding and milking, there is a greater opportunity for the herdsman to observe welfare problems in individual cows. The introduction of milking parlours referred to above enabled farmers to increase herd size without increasing labour input, as a result of the adoption of loose housing and mechanized feeding.

More recently the development of fully automatic milking systems (AMS), without an attendant milker, has further enabled labour input to be reduced. AMS works best with permanently housed cows, and they may be difficult to manage when cows are grazing a long distance from the farm buildings. Increasing number of cows per farm and difficulties in adequately feeding high yielding cows at pasture is also encouraging farmers to retain cows in housing systems (Van den Pol-van Dasselaar *et al.*, 2002). In a recent Dutch survey 75% of farms with less than 80 cows pastured their cows during summer, but only 40% of farms with more than 160 cows did this (Hopster and Zijlstra, 2011).

The annual duration and type of housing for dairy cows has important consequences for their behaviour, health and welfare, and in this chapter these are explored, with particular reference to the ability of the housing systems to support the natural behaviour of dairy cows. We do not attempt to address all aspects of dairy cow behaviour and health in relation to housing, but focus

## 2. A review of the impact of housing on dairy cow behaviour, health and welfare

on the aspects that are most relevant to welfare, and compare them with the cows' situation on pasture. Further details of comparisons between cubicle houses, tie-stalls and straw yards are provided elsewhere (Singh *et al.*, 1994; Webster, 2002).

### 2.2. The effects of housing dairy cows on their opportunities to perform natural behaviour

#### 2.2.1. Foraging and ruminating

Placing dairy cows in a house usually means that farmers offer conserved feed, so that they do not have to cut and carry fresh food to the cows every day. If the cows were at pasture they would typically graze for 6-12 hours per 24 hours, depending on factors such as nutrient requirements and availability, ingestion speed, weather conditions and competition for food (Coffey *et al.*, 1992). The grazing activity is crepuscular, especially in cattle with low nutrient requirements (Gonyou and Stricklin, 1984; Phillips, 2002), leading to a high degree of synchronicity in feeding behaviour. By contrast housed cows forage, i.e. search for and ingest food, for much less time than grazing cows, typically only around 4 hours per 24 hours (Phillips, 2002; Wierenga and Hopster, 1990). This is because search and prehension times are shorter and bite size is larger (Phillips, 2002). Feed tossing is an abnormal behaviour that occurs when loose housed cows are fed a conserved feed diet (Albright and Arave, 1997). Another abnormal oral behaviour, tongue rolling occurs when housed cattle are offered limited feed, especially in combination with limited movement opportunities, e.g. when tethered (Redbo and Nordblad, 1997). This is best prevented by allowing cows access to pasture for at least a short period each day. Intersucking, i.e. sucking on the teat of another cow and drinking milk, occurs occasionally in loose housing, and it can partly be related to the feeding system (Lidfors and Isberg, 2003). Self-sucking may occur in tied cows, but is less common than intersucking (Lidfors and Isberg, 2003). It has been suggested that in many situations the relatively large amount of time that housed cows spend foraging and ruminating compared to non-ruminants, about 12 hours per day, both satisfies their needs in relation to food intake and prevents boredom (Houpt, 1987).

A significant difference between foraging indoors and on pasture is that in the latter feeding takes place during a slow forward movement. This makes it easier for cows to reach the ground with their muzzles and with their forelegs in the stepping position. In housing systems, cows are constrained behind a static vertical barrier and push forwards to reach food in front of them. Troughs are sometimes raised 10 to 20 cm above ground level to allow the cows to feed with their forelegs in the necessary perpendicular position at the trough or feeding barrier. If the feeding table is not raised sufficiently the load on the shoulder and forelegs is greater and the animals may become lame and develop shoulder lesions (Waiblinger *et al.*, 2001). The different feeding situation of housed cattle also means that they are generally less active than grazing cattle (Schofield *et al.*, 1991; Krohn *et al.*, 1992), which may reduce their physical condition and the ease of lying down movements (Krohn and Munksgaard, 1993). It may also reduce claw health.

In some extensive grazing situations, cows have access to a selection of herbs and grass species, whereas feed offered indoors provides little or no opportunity for selection, depending on the ingredients and method of preparation. Although the mean intake of a group of cows

fed individually is similar to that of cows in a loose housing system (Broadbent *et al.*, 1970), individually-fed cows have little opportunity for selection. Similarly if feed is offered as a complete diet (Total Mixed Ration, TMR), although there is good control by the farmer of mean dietary intake, cows have reduced possibility to select according to individual needs, which may be possible on pasture. There is, however, evidence of avoidance of long, fibrous particles and preferential consumption of high quality elements in the mix (De Vries *et al.*, 2005; Leonardi and Armento, 2007). Cows at pasture are at risk of consuming poisonous plants, but may also learn to avoid these, whereas their provision in the form of conserved forage may not alert cows to their toxic nature.

Cattle normally spend 4-8 hours per 24 hours ruminating (Wierenga and Hopster, 1990), which is an important activity for the proper digestion of the food. Any limitation to rumination times can similarly jeopardise the metabolic processes in a dairy cow. As rumination is carried out mostly whilst lying, an absence of opportunity for comfortable lying may also effect rumination times (Chaplin *et al.*, 2000). Conditions at pasture are usually favourable in this regard.

### **2.2.2. Thermoregulatory behaviour**

Housing potentially provides protection from aversive climatic conditions (Legrand *et al.*, 2009), but depending on housing quality it may also exacerbate extremes. For instance, some buildings with low metallic roofs may increase indoor temperatures compared with ambient temperature, potentially creating heat stress in cows. Cows may be unable to recuperate from low temperatures by gaining radiant heat from the daytime sun. In cold conditions cows increase their absorption of solar radiation by exposing as much of their body as possible to the sun's rays, standing at right angles to it (Arnold and Dudzinsky, 1978). However, with their large surface area to volume ratio, high rate of rumen fermentation and milk production, cows have a large heat output, which usually makes them more susceptible to heat than cold stress. In unadapted animals, ambient temperatures above 22 °C are associated with production losses and increased somatic cell counts, especially in high yielding animals (Hogeveen *et al.*, 2001). In response to heat, cows show increased water intake and respiratory frequency, decreased food intake, milk production and reproduction (Silanikove, 2000). At ambient temperatures above 24 °C, milk temperatures of high yielding animals increase (Moreira da Silva, 1986), providing evidence of physiological stress. Cattle can sometimes seek shade at pasture to mitigate high temperatures (Goodwin *et al.*, 1997), but the recent intensification of pasture management has left many pastures without hedges, trees and other forms of shelter from solar radiation.

Given the opportunity, cows prefer to stay inside if rainfall increases the loss of body heat in cold conditions (Krötzel and Hauser, 1997); in warm conditions they readily go outside in rainfall (Vandenheede *et al.*, 1994). In extreme latitudes, particularly in Canada and north-east Europe, cows in uninsulated buildings could potentially be subjected to cold stress. Under such conditions cows will increase rumination activity, reticulorumen motility and rate of passage of digesta, resulting in a less efficient digestion but increased intake and heat production. In most conditions, the internal temperature of an uninsulated building is at least 3-6 °C above ambient temperature and wind chill is diminished, hence the thermal conditions for cows are unlikely to fall below their lower critical temperature (approximately -20 °C). If it does, cows will shiver and huddle

## 2. A review of the impact of housing on dairy cow behaviour, health and welfare

to maintain core body temperature. However, there is a much greater risk to cows that are sick and not eating normally. Having large amounts of dry bedding is beneficial for dairy cows, but if the bedding is wet cows will avoid lying on it at low temperatures, as they would increase heat loss compared to when they are standing. In Canada cold temperatures can reduce claw blood circulation sufficiently to increase subclinical laminitis (Vermunt, 1990). The temperature of the drinking water has a significant impact on the extent of thermal stress experienced by cows. Cows drink approximately five times their milk yield daily, and the water temperature can be increased by insulating water pipes and running them around the ceiling of the building. If cows are exposed to cold temperatures over several weeks, their coat will thicken and they will increase the depth of their subcutaneous fat layer. Insulating a building and reducing ventilation may conserve heat, but will also increase the concentration of noxious gases, especially ammonia and carbon dioxide, and airborne pathogens.

### 2.2.3. Social behaviour

#### *Behaviour synchronisation*

Cows are gregarious animals that synchronise their behaviour, in particular foraging and resting (Metz and Wierenga, 1987). Behaviour is more synchronised at pasture than in houses (Krohn *et al.*, 1992), where there is limited space availability and greater competition for lying and eating places (Wierenga *et al.*, 1985). Low ranking animals are affected most by such competition and are likely to engage in essential behaviours, such as feeding, at times when high ranking animals are resting, in particular at night. Increased synchronisation of grazing cows could also be an anti-predator strategy, and there is evidence of increased vigilance in small groups of cows at pasture (Rind and Phillips, 1999). Poor synchronisation of behaviour in housed situations reflects a deviation from preferred behaviour patterns and may be indicative of reduced welfare. In such situations, it may be more difficult for stockpersons to spot 'deviant' or abnormal behaviour and to provide proper health care.

#### *Personal space*

Cows experience a conflict between two motivations, first to seek the safety of their herd and second to avoid inter-species aggression. The preferred distance between animals depends on the degree of familiarity between the animals, with the smallest distances being between animals that were raised together, and the behavioural context. The type of cow, and particularly the presence of horns, may affect inter-individual distance, but to date there have been insufficient studies to determine this with any certainty. In loose-housing systems cows are forced to be closer to one another (<1 m) than generally observed at pasture ( $\geq 14$  m, Rind and Phillips, 1999). Often cubicles for Friesian cows are only 110-120 cm wide and space for eating only 65 cm if all animals feed at once. With increasing number of cubicles available cows increase their personal space (Wierenga *et al.*, 1985), often leaving empty cubicles between them. Inadequate cubicle provision decreases lying times and increases agonistic interactions (Friend *et al.*, 1977) and consequently is associated with more lameness (Rouha-Mülleder *et al.*, 2009). Similarly, a restricted number of feeding places increases the number of agonistic interactions and decreases synchronicity (Metz and Mekking, 1984; Huzzey *et al.*, 2006). High stocking densities increase stress (Beneke

*et al.*, 1983) and particularly restrict the movements of low ranking cows, for example if they are obstructed by high ranking animals as they leave their cubicle (Metz and Mekking, 1984).

### *Grooming behaviour*

Grooming others, allogrooming, is a form of social licking that is typically directed towards parts of the body, such as the head, neck, shoulder (Sambraus, 1969), back and tail (Sato *et al.*, 1991) that are difficult for the animal to reach. Both selfgrooming and allogrooming are usually considered signs of good health (Albright and Arave, 1997), but if increased, may also be signs of understimulation or social conflict (Knierim and Winckler, 2009). Heart rate measurements suggest that social licking has a calming effect on receivers (Sato and Kuroda, 1993; Laister *et al.*, 2011), and it is thought to strengthen bonds between animals (Sato *et al.*, 1993). Releasing tied cows regularly to exercise encourages licking behaviour of herdmates that could not otherwise be reached when the cows are tied (Loberg *et al.*, 2004).

### *Agonistic behaviour*

Agonistic behaviour includes overt aggression, but also more subtle behaviours, such as giving other animals priority of movement (Bouissou *et al.*, 2001). Low ranking animals typically respond to threats by making way with their head in a low position and averted from the dominant animal. When threats do not achieve the desired appeasement movements, dominant cows may strike the rump of their opponent with their head if dehorned or use the tip of their horns against the body of other cows. Actual fights, which typically involve animals of similar rank, vary in length, but most (80%) confrontations are settled within one minute (Bouissou, 1974). The incidence of agonistic behaviour increases with herd size and decreases with living space (Kondo *et al.*, 1989; Rind and Phillips, 1999). The limited living space in houses increases the number of encounters and reduces the opportunities for subordinate cows to avoid higher ranking conspecifics, compared to pasture (Wierenga, 1984; Miller and Wood-Gush, 1991). At pasture feeding and drinking are usually not associated with agonistic interactions, whereas in houses the feeding and drinking areas attract the most agonistic encounters. If present, concentrate stations are the site of many social interactions (Wierenga, 1984). Agonistic interactions that take place on concrete floors result more often in cows slipping and falling than on earth (Sommer, 1985) and this increases the risk of lameness (Webb and Nilsson, 1983). Thus in cubicle houses significant social unrest and consequently increased risks of injuries impair the welfare of dairy cows, compared with pasture-based feeding.

## **2.2.4. Locomotion and resting**

### *Locomotion*

Locomotion is necessary to provide access to, for example, water, food, herd mates and safety. Cows at pasture may walk 1-13 km per day depending, for example, on the size of the pasture (Arnold and Dudzinski, 1978), the grazing system (Walker *et al.*, 1985) and the location of water sources. Estimates for the daily walking distance of cows in loose-housing systems vary from 300-900 m (Kempkens, 1989) to 2-4 km (Schofield *et al.*, 1991), with a large variation between

## 2. A review of the impact of housing on dairy cow behaviour, health and welfare

cows, e.g. 200 to 2,500 m (Kempkens and Boxberger, 1987). Exercise stimulates muscle and bone growth during development and in general promotes locomotor function. Cows that receive exercise on a daily basis are more agile than cows in tie-stalls (Gustafson and Magnussen, 1996), and have fewer calving-related diseases, mastitis and leg problems (Gustafson, 1993).

Tied cows exhibit significantly increased locomotion (rebound behaviour) once they enter a paddock (Loberg *et al.*, 2004; Veissier *et al.*, 2008), demonstrating that they were thwarted from performing adequate exercise inside. Cows kept in cubicle houses with slatted floors move with less flexibility in their hock and elbow joints than those walking at pasture (Herlin, 1994). On solid concrete cows typically walk slowly and have their attention focussed on the floor (Sommer, 1985). In cubicle houses with concrete floors cows move stiffly and with restraint, especially if there is deep slurry (Phillips and Morris, 2000). In passageways, Albutt and Dumelow (1987) showed that cows slip more when they walk on concrete than on earth, but if the slurry is deep it stabilises the cows' leg action (Phillips and Morris, 2000). Slippery floors cause reduced and abnormal locomotion, reduced lying times and abnormal lying down and standing up motions (Albutt and Dumelow, 1987; Herlin, 1994; Sommer, 1985). Dairy cows prefer both standing and walking on rubber floors (Telezhenko *et al.*, 2007). Low intensity lighting also impairs walking in cubicle houses, and cows avoid poorly lit passageways (Phillips *et al.*, 2001). Buildings that support exercise are important for the welfare of cows, but the minimal amount of exercise required is not yet known.

The restricted locomotion and resting by cows in cubicle houses adversely affect cows' health (Chaplin *et al.*, 2000; Gustafson, 1993; Gustafson and Magnussen, 1996). By comparison, pasture allows unobstructed locomotion, fluid lying down and natural standing up motions and comfortable resting (Sonck *et al.*, 1999; Krohn and Munksgaard, 1993).

### *Standing up and lying down*

Neck and head rails in cubicles force cows to back out when standing up and prevent them from going too far into the cubicle, thus ensuring that faeces are deposited in the alley rather than on the bed of the cubicle. Often, in the process of lying down or standing up, the natural motions of the cows and the distribution of their weight are obstructed by these rails. This may result in unwanted loading of the legs and abnormal behaviour, such as getting up with the front legs first (Lidfors, 1989). Problems occur especially for large animals and / or when the design of cubicles does not meet recommended standards (e.g. CIGR, 1994). Cubicles that have high quality deep straw or sand bedding, flexible separations and sufficient dimensions with respect to width, length, neck rail distance and height, and space for forward head movement when rising, provide the most comfort (Veissier *et al.*, 2004). Cows' comfort level may be indicated by the time taken to lie down (Herlin, 1997; Lidfors, 1989; Plesch *et al.*, 2010), which is longer on concrete floor than at pasture, and reduced by soft cubicle bedding (Herlin, 1997). Abnormal lying down and standing up motions cause injuries and may be considered as signs of reduced comfort, i.e. welfare, in themselves.



### *Resting*

The length of time that cows spend lying may indicate their satisfaction with the lying area provided. Cows lie for longer and stand less in cubicles with rubber mats than on concrete floors bedded with sawdust (Sonck *et al.*, 1999). Cows prefer bedding that is soft and large cubicles (Fulwider and Palmer, 2004). Having more than one cubicle per cow will allow some cows to use adjacent empty cubicles to stretch their legs in a laterally recumbent position, which is common in cows at pasture (Andreae *et al.*, 1985). Both of these characteristics, softness and space, are constrained in standard cubicles, with the result that welfare whilst lying is worse than when the cow is at pasture. This explains why cows given the choice between resting inside in cubicles or outside on grass tend to choose the latter, and why at pasture they spend more time lying than they do in cubicles (Krohn and Munksgaard, 1993; Legrand *et al.*, 2009).

#### **2.2.5. Reproductive behaviour**

Cows on hard, moist and slippery floors move cautiously and exhibit less oestrus behaviour (Webb and Nilsson, 1983). Limited space may also cause cows in cubicle houses to reduce the expression of oestrus behaviour (Britt *et al.*, 1986; Vailes and Britt, 1990). Whether this impairs welfare is unclear, but it may signal welfare problems that are related to obstructed locomotion. Cows on earth floors show more mounting and standing reflexes, as well as a longer period of oestrus behaviour, than those on concrete floors (Britt *et al.*, 1986). Even when the latter are dry and rough cows will show limited homosexual mounting (Vailes and Britt, 1990).

### **2.3. Health and reproduction in relation to housing**

#### **2.3.1. Locomotor apparatus**

Housing has the potential to reduce the health of the locomotor apparatus and hence is associated with more lameness than in grazing systems (Greenough *et al.*, 1981; Hernandez-Mendo *et al.*, 2007). However, the latter can have high levels of lameness if cows are forced to walk too fast over rough hard core tracks, causing frequent loss of balance and injuries (Greenough *et al.*, 1981), which is most likely when they are being collected from the fields for milking.

Within the different housing systems there is considerable variation in lameness susceptibility. For example, lameness is more common in loose housing than in tie stalls (+200-300% for white line disease, +50% for haemorrhaging, +50% for sole ulcers, Kujala *et al.*, 2009, 2010), particularly if the stalls are without rubber mats. Although some research has suggested a preventive effect of heel wear in loose housing (Kujala *et al.*, 2010), the exposure to floors that are wet, slippery and rough, together with increased cow interactions, increases stresses on the hoof, potentially leading to lameness. In extreme cold conditions floors covered with frozen water or slurry are major hazards for cows, which are likely to slip and cause injury to hoof or supporting ligaments. Another major risk factor for lameness in loose housing systems is slatted floors, probably due to uneven pressure on the claws and a high occurrence of defective slats (Dippel *et al.*, 2009b; Rouha-Mülleder *et al.*, 2009). Floor scrapers can help to reduce lameness on slatted floors, in particular interdigital dermatitis, heel erosion and digital dermatitis (Somers *et al.*, 2003), in part

## 2. A review of the impact of housing on dairy cow behaviour, health and welfare

by creating a drier surface. High incidences of infective claw diseases, such as footrot (*Dermatitis interdigitalis*) and Italian footrot (*Dermatitis digitalis*), are also associated with housing (Smits *et al.*, 1992). In Holland the incidence of Italian footrot has increased with greater use of cubicle systems, as the disease rarely occurs in cows in straw yards (Somers *et al.*, 2001). Features commonly found in cubicle houses (small/hard cubicles and slippery, hard and slurry-covered floors) facilitate injuries, locomotion problems and lameness (Phillips, 1990; Smits *et al.*, 1992; Singh *et al.*, 1994; Somers *et al.*, 2001; Dippel *et al.*, 2009a,b; Rouha-Mülleder *et al.*, 2009). After the cows have been transferred from pasture into houses, locomotor problems become more frequent (Boelling and Pollott, 1998), but this may also happen if the transition is reversed and the cows are allowed outside only during the daytime. For cows inside overnight, the regular immersion of hooves in slurry will soften the claws and make them vulnerable to wear and injury (Phillips, 1990).

The rails and hard floors of cubicles can cause significant injuries to cows' feet (Singh *et al.*, 1994). Soft rubber mats or mattresses in cubicles are often used by farmers to avoid adding bedding to the cubicle, but lead to more injuries and skin lesions on the legs of cows compared to cubicles with a high quality straw bedding (e.g. a straw dung mattress) (Wechsler *et al.*, 2000). There are more skin lesions, subcutaneous swellings or swollen hocks in cubicles with rubber mats and, to a lesser extent, mattresses, than in a straw yard (Livesey *et al.*, 1998). Sand, however, provides a comfortable bedding and low risk of mastitis (van Gastelen, 2011). The hardness of the floor is the key factor, with more skin lesions, swellings and injuries in tied cows on hard than soft bedding. High yielding cows are increasingly large and angular, making them more vulnerable to leg injuries on hard lying surfaces. Daily access to pasture for several hours can sometimes reduce lameness and hock lesions, even increasing longevity as a result (Wiederkehr *et al.*, 2001). Taken as a whole, conditions in cubicle houses are likely to facilitate injuries, locomotion problems and lameness in dairy cows. Such conditions may be painful and typically last for one month (Phillips, 1990), seriously reducing cow welfare.

### 2.3.2. Udder health

#### *Mastitis*

The incidence of high somatic cell counts in milk, a potential sign of mammary gland inflammation, is increased in cows that are kept permanently indoors (Goldberg *et al.*, 1992), whereas grazing is generally associated with reduced incidence of mastitis (Washburn *et al.*, 2002). At pasture, infection pressure is low and teat injuries, which facilitate the entrance of bacteria, are less likely to occur (Goldberg *et al.*, 1992). An epidemiological study in Sweden showed that mastitis occurred at a higher incidence during housing than during the time at pasture, and there was a decreased incidence in loose-housed cows when compared to tied cows (Bendixen *et al.*, 1988a), which experience more tramped teats (Bendixen *et al.*, 1988b). An exception is summer mastitis transmitted by head flies (*Hydrotea irritans*) that typically live outside near trees and bushes. However, adequate preventive measures exist and the increased incidence of the mastitis that is transmitted by head flies during grazing does not counter the overall positive effect of grazing on udder health.



Mastitis incidence is also a function of cleanliness of the environment. A Canadian survey found 27 cases of mastitis/100 cow years in tie stalls, compared with just 19 for loose housing, which is easier to clean mechanically (Olde Riekerink *et al.*, 2008). The bacteria involved are more likely to be of environmental origin in loose housing, such as *Escherichia coli* types, because of the increased potential for the udder to contact faeces, whereas in tie stalls the transmissible *Staphylococcus aureus* and *Streptococci* are more common, with infection being usually passed between cows by the use of common cleaning cloths.

### **2.3.3. Metabolic disorders**

Metabolic disorders are strongly influenced by diet, which is in turn usually affected by the type of housing. The supply of a constant well-balanced diet for high-yielding dairy cows is more difficult to realise when cows are at pasture than when they are kept inside. In particular housing reduces the prevalence of many mineral imbalances, due to an increased ability to maintain a sufficient intake of potentially deficient elements, for example calcium and magnesium (Mg) through supplementation (Underwood and Suttle, 1999). Hypomagnesaemia from Mg deficiency or reduced Mg absorption is typically caused by spring grass consumption with high contents of potassium (K) or crude protein. The risk of bloat is high when cows graze swards with young, leafy legumes such as white clover (Phillips *et al.*, 1996), but conserved forage can reduce this risk.

Many adverse effects of young, leafy pasture on the health of high yielding dairy cows can be avoided if forage supplements are provided (Phillips, 1988). The use of fertilisers and the consumption of pasture grass in an early growing stage results in food with a relatively high protein to carbohydrate ratio, compared with consumption of silage or hay. Small fractions of carbohydrates that, in addition, are readily degradable, accelerate the passage of food through the rumen. This reduces the microbial mass in the rumen and the utilisation of nitrogen. High intake of nitrate in combination with low intake of carbohydrates can impair the conversion of nitrate into ammonia and raise levels of nitrite (NO<sup>2-</sup>) in the rumen and blood. At high concentrations NO<sup>2-</sup> interferes with the transport of oxygen, the vitamin A and iodine (I) metabolism, and it can lead to abortion (Whitehead, 1995). There are some specific risks to feeding conserved forage in housing systems. In silage, micro-organisms, mycotoxins and excess acidity are examples of forage-specific hazards to animal health (Wilkinson, 1999).

### **2.3.4. Infectious diseases and parasites**

Parasites such as gastro-intestinal worms, lung worms and sheep liver fluke (*Fasciola hepatica*) are less common in housed cows than those at pasture (Borgsteede and Burg van der, 1982). Such parasites may cause significant loss of body condition and milk production in cows that have not acquired immunity at a young age, and they are usually acquired through consumption of contaminated pasture. However, they may also be acquired through contact with faeces, which is more likely in housed cows than those at pasture (Whistance *et al.*, 2007). This increases the risk of serious infections (Longhurst *et al.*, 2000). At pasture there is a greater risk of contact with faeces if the pastures are grazed intensively (Hutchings and Harris, 1997). In housed cows, faecal deposits are more easily avoided in straw bedded yards than cubicle housing (Whistance *et al.*, 2011).

## 2. A review of the impact of housing on dairy cow behaviour, health and welfare

Silage from pastures that were recently grazed by cows may also be contaminated with pathogens (Wilkinson, 1999). Paratuberculosis, for example, can spread amongst cows through the faeces of rabbits and other wild animals (Hutchings and Harris, 1997; Daniels *et al.*, 2001). Bovine tuberculosis is suspected of being spread through badger excreta in the British Isles, which may be deposited in TMR when badgers enter buildings to feed (Phillips *et al.*, 2003). Neosporosis, which can endanger pregnancy, is transmitted via the faeces of dogs (Solen, 2002).

If cows acquire immunity at a young age and are prevented from grazing on highly contaminated pastures, the risk of serious health problems caused by pasture parasites is small. Infectious diseases, e.g. bovine tuberculosis, Infectious Bovine Rhinotracheitis (IBR), Bovine Virus Diarrhoea (BVD) and paratuberculosis, can theoretically be transmitted to contiguous farms by cow to cow contact across fence lines, or in the case of *Salmonella* and neosporosis, via water in ditches. However, these risks have not been confirmed epidemiologically (Schaik van *et al.*, 1998). Cows in housing systems are kept at higher stocking density than grazing cows, thereby increasing the propensity to acquire diseases through droplet infection. The greatest health risk for housed cows is of a build-up of micro-organism loads in houses that are continuously stocked and without sunlight and desiccation to kill micro-organisms.

### 2.3.5. Environmental pollution

Inside buildings poor ventilation may lead to harmful levels of volatile substances, such as ammonia and sulphur compounds, especially during the mixing of slurry. High concentrations of microbes and dust particles inside closed houses may cause respiratory problems. At pasture dairy cows are more likely to be exposed to localised environmental pollution problems, such as lead poisoning. Drinking water from streams that are contaminated by sewage may cause infection problems (Meijer *et al.*, 1999; Phillips *et al.*, 2003). In the case of industrial accidents, such as radioactivity leaks, contaminated grass may be ingested by the cows before preventive actions can be taken.

### 2.3.6. Reproduction and partus related disorders

Some research reported higher fertilisation rates for grazing than for permanently housed cows (Rehn *et al.*, 2000), though others have not been able to confirm this (Phillips, 1990; Washburn *et al.*, 2002). The consumption of young pasture grass can lead to a surplus of rumen degradable protein that is cleared with an energy cost that could impair fertility (Butler, 1998). Protein metabolism also increases blood urea concentration, and this has been hypothesised to lower prostaglandin production and impairs LH binding to its receptors in the ovaries. Thereby it is believed to reduce ovarian activity. However, at present, there is no clear evidence that grazing promotes such problems.

In an epidemiological study with tied and loose-housed cows, Swedish Red cows in loose-housing had a lower incidence of parturient paresis than permanently housed tied cows, but no such difference was found in Swedish Friesian cows (Bendixen *et al.*, 1987b). Also, loose-housed cows had a lower incidence of retained placenta and dystocia than tied cows (Bendixen *et al.*, 1986, 1987a). Reproductive success may be reduced in crowded housing (Alban and Agger, 1996), for

example, by reducing the expression of oestrus behaviour or increasing lameness (Collick *et al.*, 1989; Arguez-Rodriguez *et al.*, 1997). Slippery floors may also cause cows in cubicle houses to suppress the expression of oestrus behaviour (Britt *et al.*, 1986; Vailes and Britt, 1990).

## **2.4. Conclusions**

The housing of dairy cows varies greatly between farms, from housing for just a small period of the day or year in order to provide supplements, to permanent housing in order to closely control the cows' diet and/or movement. In other cases the location or weather makes grazing systems difficult to manage. Increasing farm size and milk output is favouring housed systems, but there are major implications for cow health and behaviour, both key components of welfare. A comparison of housing systems generally favours deep straw housing, rather than cubicles or tie stalls, for most aspects of welfare. The knowledge about housing systems has increased significantly in recent years, and this review should encourage farmers to adopt improved systems for their dairy cows in future, including grazing in conjunction with housing where appropriate and possible.

## **Acknowledgements**

A workshop in the 2002 meeting of the International Society of Applied Ethology formed the basis for this chapter. The assistance of the Dutch Ministry of Agriculture Nature and Fisheries and the Dairy Industry (Productschap Zuivel) and Fred H.M. Borgsteede is appreciated.

## **References**

- Alban, L. and Agger, J.F., 1996. Welfare in Danish herds. *Acta Veterinariae Scandinavica* 37: 65-77.
- Albright, J.L. and Arave, C.W., 1997. *The Behaviour of Cattle*. CAB International, Wallingford, UK, 306 pp.
- Albutt, R.W. and Dumelow, J., 1987. An online computer technique for measuring foot movement of cattle to assess the skid resistance of various floor surfaces. In: Wierenga, H.K. and Peterse, D.J. (eds.) *Cattle Housing Systems, Lameness and Behaviour*. Martinus Nijhoff Publishers, Dordrecht, the Netherlands, pp. 56-62.
- Andrae, U., Beneke, B. and Schmidt, D., 1985. Ethologische Erhebungen über Raumbedarf und Raumnutzung bei Jungrindern und Milchkühen. (Ethological enquiries on space requirement and use by young cattle and dairy cows: in German) *Landbauforschung Völkenrode* 75: 58-84.
- Arguez-Rodriguez, F.J., Hird, D.W., Hernandez de Anda, J., Read, D.H. and Rodriguez-Lainz, A., 1997. Papillomatous digital dermatitis on a commercial dairy farm in Mexicali, Mexico: Incidence and effect on reproduction and milk production. *Preventive Veterinary Medicine* 32: 275-286.
- Arnold, G.W. and Dudzinski, M.L., 1978. *Ethology of Free Ranging Domestic Animals*. Elsevier Scientific Publishing Company, Shers, Amsterdam, pp. 198.
- Bendixen, P.H., Vilson, B. Ekesbo, I. and Åstrand, D.B., 1986. Disease frequency in Swedish dairy cows I. Dystocia. *Preventive Veterinary Medicine* 4: 307-316.
- Bendixen, P.H., Vilson, B. and Ekesbo, I., 1987a. Disease frequency in dairy cows in Sweden II. Retained placenta. *Preventive Veterinary Medicine* 4: 377-387.
- Bendixen, P.H., Vilson, B. Ekesbo, I. and Åstrand, D.B., 1987b. Disease frequency in dairy cows in Sweden III. Parturient paresis. *Preventive Veterinary Medicine* 5: 87-97.

## 2. A review of the impact of housing on dairy cow behaviour, health and welfare

- Bendixen, P.H., Vilson, B., Ekesbo, I. and Åstrand, D.B., 1988a. Disease frequency in dairy cows in Sweden V. Mastitis. *Preventive Veterinary Medicine* 5: 263-274.
- Bendixen, P.H., Vilson, B., Ekesbo, I. and Åstrand, D.B., 1988b. Disease frequency in dairy cows in Sweden VI. Tramped teat. *Preventive Veterinary Medicine* 6: 17-25.
- Beneke, B., Ladewig, J., Andreae, U. and Smidt, D., 1983. Physiologische und Ethologische Merkmale bei Belastungssituationen von Rindern. (Physiological and ethological parameters in cattle that are challenged: in German). In: *Aktuelle Arbeiten zur artgemäßen Tierhaltung*, KTBL-Schrift 299, Darmstadt, Germany, pp. 32-45.
- Boelling, D. and Pollott, G.E., 1998. Locomotion, lameness, hoof and leg traits in cattle I. Phenotypic influences and relationships. *Livestock Production Science* 54: 193-203.
- Borgsteede, F.H.M. and Van der Burg, W.P.J., 1982. Worm burdens in cows II. An analysis of the population of nematodes in the abomasa of adult dairy cows. *Veterinary Parasitology* 10: 323-330.
- Bouissou, M.F., 1974. Etablissement des relations de dominance-soumission chez les bovines domestiques. I. Nature et évolution des interactions sociales. *Annales de Biologie Animale, Biochimie et Biophysique* 14: 383-410.
- Bouissou, M.F., Boissy, A., Le Neindre, P. and Veissier, I., 2001. The bovines among other bovids: social structure of wild bovines. In: Keeling, L. and Gonyou, H. (eds.) *Social Behavior in Farm Animals*, CAB International, Wallingford, UK, pp. 113-145.
- Britt, J.H. Scott, R.G. Armstrong, J.D. and Whitacre, M.D., 1986. Determinants of estrous behavior in lactating Holstein cows. *Journal of Dairy Science* 69: 2195-2202.
- Broadbent, P.J. McIntosh, J.A.R. and Spence, A., 1970. The evaluation of a device for feeding group-housed animals individually. *Animal Production* 12: 245-252.
- Butler, W.R., 1998. Review: Effect of protein nutrition on ovarian and uterine physiology in dairy cattle. *Journal of Dairy Science* 81: 2533-2539.
- Chaplin, S.J., Tierney, G., Stockwell, C., Logue, D.N. and Kelly, M., 2000. An evaluation of mattresses and mats in two dairy units. *Applied Animal Behaviour Science* 66: 263-272.
- CIGR, 1994. Design recommendations dairy cow housing. Section II: Working group no 14 cattle housing. ADAS Bridgets Dairy Research Centre Farm Buildings Research Team.
- Coffey, K.P., Moyer, J.L., Brazle, F.K. and Lomas, L.W., 1992. Amount and diurnal distribution of grazing time by stocker cattle under different tall fescue management strategies. *Applied Animal Behaviour Science* 33: 121-135.
- Collick, D.W. Ward, W.R. and Dobson, H., 1989. Associations between types of lameness and fertility. *Veterinary Record* 125: 103-106.
- Daniels, M.J. Ball, N. Hutchings, M.R. and Greig, A., 2001. The grazing response of cattle to pasture contaminated with rabbit faeces and the implications for the transmission of paratuberculosis. *The Veterinary Journal* 161: 306-313.
- De Vries, T.J., Von Keyserlingk, M.A.G. and Beauchemin, K.A., 2005. Frequency of feed delivery affects the behavior of lactating dairy cows. *Journal of Dairy Science* 88: 3553-3562
- Dippel, S., Dolezal, M., Brenninkmeyer, C., Brinkmann, J., March, S., Knierim, U. and Winckler, C., 2009a. Risk factors for lameness in freestall-housed dairy cows across two breeds, farming systems, and countries. *Journal of Dairy Science* 92: 5476-5486
- Dippel, S., Dolezal, M., Brenninkmeyer, C., Brinkmann, J., March, S., Knierim, U. and Winckler, C., 2009b. Risk factors for lameness in cubicle housed Austrian Simmental dairy cows. *Preventive Veterinary Medicine* 90: 102-112

- Friend, T.H., Polan, C.E. and McGilliard, M.L., 1977. Free stall and free bunk requirements relative to behaviour, production and individual feed intake in dairy cows. *Journal of Dairy Science* 60: 108-116.
- Fulwider, W.K. and Palmer, R.W., 2004. Use of impact testing to predict softness, cow preference, and hardening over time of stall bases. *Journal of Dairy Science* 87: 3080-3088
- Goldberg, J.J. Wildman, E.E. Pankey, J.W. Kunkel, J.R. Howard, D.B. and Murphy, B.M., 1992. The influence of intensively managed rotational grazing, traditional continuous grazing and confinement housing on bulk tank milk quality and udder health. *Journal of Dairy Science* 75: 96-104.
- Gonyou, H.W. and Stricklin, W.R., 1984. Diurnal behavior patterns of feedlot bulls during winter and spring in northern latitudes. *Journal of Animal Science* 58: 1075-1083.
- Goodwin, P.J., Gaughan, T.A., Schoorl, T.A. Young, B.A. and Hall, A., 1997. Shade type selection by Holstein-Friesian dairy cows. In: Bottcher, R.W. and Hoff, S.J. (eds.) *Livestock Environment V, Vol. II*, ASEA, Michigan, USA, pp. 915-921.
- Greenough, P.R. MacCallum, F.J. and Weaver, A.D., 1981. *Lameness in Cattle*. 2<sup>nd</sup> edition, edited by Weaver, A.D. Wright Scientifica, John Wright & Sons Ltd, Bristol, UK.
- Gustafson, G.M., 1993. Effect of daily exercise on the health of tied dairy cows. *Preventive Veterinary Medicine* 17: 209-223.
- Gustafson, G.M. and Magnussen, L.E., 1996. Effect of daily exercise on the getting up and lying down behaviour of tied dairy cows. *Preventive Veterinary Medicine* 25: 27-36.
- Herlin, A.H., 1994. Effects of tie-stalls or cubicles on dairy cows in grazing or permanent housing situations. Studies on behaviour, locomotion, hygiene, health and performance. Report 228, University of Uppsala, Sweden.
- Herlin, A.H., 1997. Comparison of lying area surfaces for dairy cows by preference, hygiene and lying down behaviour. *Swedish Journal of Agricultural Research* 27: 189-196.
- Hernandez-Mendo, O., Keyserlingk, M.A.G. von, Veira, D.M. and Weary, D.M., 2007. Effects of pasture on lameness in dairy cows. *Journal of Dairy Science* 90: 1209-1214.
- Hogeveen, H. Poelarends, J.J. Sampimon, O.C. and Miltenburg, H.D., 2001. Heat stress in a mild climate: Dutch experiences. Proceedings of the Workshop on Robotic Milking and Heat Stress, 20 Nov, Wageningen University Social Sciences, Wageningen, the Netherlands.
- Hopster, H. and Zijlstra, J.T., 2011. Koudmerken, actualisatie van het gebruik van koudmerken op Nederlandse melkvee bedrijven. Report by Lectoraat Welzijn van Dieren, Hogeschool Van Hall Larenstein, Leeuwarden, the Netherlands. Available at: <http://www.dierenwelzijnsweb.nl>.
- Houpt, K.A., 1987. Abnormal behaviour. In: Price, E.O. (ed.) *The veterinary clinics of north America: farm animal behavior*. Vol. 3(2), W. B. Saunders Company, Philadelphia, PA, USA, pp. 357-367.
- Huzzey, J.M., DeVries, T.J., Valois, P. and Keyserlingk, M.A.G., 2006. Stocking density and feed barrier design affect the feeding and social behavior of dairy cattle. *Journal of Dairy Science*, 89: 126-133.
- Hutchings, M.R. and Harris, S., 1997. Effects of farm management practices on cattle grazing behaviour and the potential for transmission of bovine tuberculosis from badgers to cattle. *The Veterinary Journal* 153: 149-162.
- Kempkens, K., 1989. Der Einfluss von Kraftfutterabruffütterung und Grundfutturvorrage auf das Verhalten von Kühen im Liegeboxenlaufstall. (The influences of feeding procedures on the behaviour of cows in cubicle houses: in German) Diss. Techn. Univ. München, Germany.
- Kempkens, K. and Boxberger, J., 1987. Locomotion of cattle in loose housing systems. In: Wierenga, H.K. and Peterse, D.J. (eds.) *Cattle Housing Systems, Lameness and Behaviour*. Martinus Nijhoff Publishers, Dordrecht, the Netherlands, pp. 107-118.

## 2. A review of the impact of housing on dairy cow behaviour, health and welfare

- Kondo, S. Sekine, J. Okubo, M. and Asahida, Y., 1989. The effect of group size and space allowance on the agonistic and spacing behavior of cattle. *Applied Animal Behaviour Science* 24: 127-135.
- Knierim, U. and Winckler, C., 2009. On-farm welfare assessment in cattle: validity, reliability and feasibility issues and future perspectives with special regard to the Welfare Quality® approach. *Animal Welfare* 18, 451-458
- Krötzel, H. and Hauser, R., 1997. Ethologische Grundlagen zum Platzbedarf, zur Gestaltung und zum Betrieb von Laufhöfen bei Kühen im Laufstall. (Principles of ethology with regards to space requirement, design and operation of walking yards: in German) *Agrartechnische Forschung* 3: 141-150.
- Krohn, C.C. and Munksgaard, L., 1993. Behaviour of dairy cows kept in extensive (loose housing/pasture) or intensive (tie stall) environments. II. Lying and lying-down behaviour. *Applied Animal Behaviour Science* 37: 1-16.
- Krohn, C.C., Munksgaard, L. and Jonasen, B., 1992. Behaviour of dairy cows kept in extensive (loose housing/pasture) or intensive (tie stall) environments 1. Experimental procedure, facilities, time budgets – diurnal and seasonal conditions. *Applied Animal Behaviour Science* 34: 37-47.
- Kujala, M., Dohoo, I.R. and Soveri, T., 2010. White-line disease and haemorrhages in hooves of Finnish dairy cattle. *Preventive Veterinary Medicine* 94: 18-27.
- Kujala, M., Dohoo, I.R., Laakso, M., Schnier, C. and Soveri, T., 2009. Sole ulcers in Finnish dairy cattle. *Preventive Veterinary Medicine* 89: 227-236.
- Laister, S., Stockinger, B., Regner, A.M., Zenger, K., Knierim, U. and Winckler, C., 2011. Social licking in dairy cattle – effects on heart rate in performers and receivers. *Applied Animal Behaviour Science* 130: 81-90
- Legrand, A.L., Von Keyserlingk, M.A.G. and Weary, D.M., 2009. Preference and usage of pasture versus free-stall housing by lactating dairy cattle. *Journal of Dairy Science* 92: 3651-3658
- Leonardi, C. and Armentano, L.E., 2007. Feed selection by dairy cows fed individually in a tie-stall or as a group in a free-stall barn. *Journal of Dairy Science* 90: 2386-2389.
- Lidfors, L., 1989. The use of getting up and lying down movements in the evaluation of cattle environments. *Veterinary Research Communications* 13: 307-324.
- Lidfors, L. and Isberg, L., 2003. Intersucking in dairy cattle – review and questionnaire. *Applied Animal Behaviour Science* 80: 207-231.
- Livesey, C.T., Johnston, A.M., Marsh, C., May, S.A. and Metcalf, J.A., 1998. The occurrence of hock injuries in primiparous Holstein cows in straw yards and cubicles with either butyl rubber mats or mattresses. *Proceedings of the 10<sup>th</sup> Symposium on Lameness in Ruminants, Lucerne, Switzerland.*
- Loberg, J., Telezhenko, E., Bergsten, C. and Lidfors, L., 2004. Behaviour and claw health in tied dairy cows with varying access to exercise in an outdoor paddock. *Applied Animal Behaviour Science* 89:, 1-16.
- Longhurst, R.D. O' Connor, M.B. Bremner, K. and Matthews L., 2000. Animal constraints to pasture treated with farm dairy effluent: preference under grazing and issues of faecal contamination. *New Zealand Journal of Agricultural Research* 43: 501-507.
- Meijer, G.A.L., De Bree, J. Wagenaar, J.A. and Spoelstra, S.F., 1999. Sewerage overflows put production and fertility of dairy cows at risk. *Journal of Environmental Quality* 28: 1381-1383.
- Metz, J.H.M. and Mekking, P., 1984. Crowding phenomena in dairy cows as related to available idling space in a cubicle housing system. *Applied Animal Behaviour Science* 12: 63-78.
- Metz, J.H.M. and Wierenga, H.K., 1987. Behavioural criteria for the design of housing systems for cattle. In: Wierenga, H.K. and Peterse, D.J. (eds.) *Cattle housing systems, lameness and behaviour.* Martinus Nijhoff Publishers, Dordrecht, the Netherlands, pp. 14-25.



- Miller, K. and Wood-Gush, D.G.M., 1991. Some effects of housing on the social behaviour of dairy cows. *Animal Production* 53: 271-278.
- Moreira da Silva, 1986. The influence of environmental and cow variables on body (milk) temperature of grazing dairy cows. Instituut voor Veelteeltkundig Onderzoek, VOS-nr. 188.
- Olde Riekerink, R.G., Barkema, M.H.W. Kelton, D.F. and Scholl D.T., 2008. Incidence rate of clinical mastitis on Canadian dairy farms. *Journal of Dairy Science* 91: 1366-1377.
- Phillips, C.J.C. Foster, C.R.W. Morris, P. and Teverson, R., 2003. The transmission of *M. bovis* infection to cattle. *Research in Veterinary Science* 74: 1-15.
- Phillips, C.J.C., 1988. The use of conserved forage as a supplement for grazing dairy cows. *Grass and Forage Science* 43: 215-230.
- Phillips, C.J.C., 1990. Adverse effects on reproductive performance and lameness of feeding grazing dairy cows partially on silage indoors. *Journal of Agricultural Science* 115: 253-258.
- Phillips, C.J.C., 2002. *Cattle Behaviour and Welfare*. 2<sup>nd</sup> edition, Blackwell Scientific Ltd, Oxford UK. 264 pp.
- Phillips, C.J.C. James, N. and Murray-Evans, J. P., 1996. Effect of forage supplements on the incidence of bloat in dairy cows grazing a high clover pasture. *Veterinary Record* 139: 162-165.
- Phillips, C.J.C. and Morris, I. D., 2000. The locomotion of dairy cows on concrete floors that are dry, wet or covered with a slurry of excreta. *Journal of Dairy Science* 83: 1767-1772.
- Phillips, C.J.C. Morris, I.D. and Lomas, C.A., 2001. A novel operant conditioning test to determine whether dairy cows dislike passageways that are dark or covered with slurry. *Animal Welfare* 10: 65-72.
- Plesch, G., Broerens, N., Laister, S., Winckler, C. and Knierim, U., 2010. Reliability and feasibility of selected measures concerning resting behaviour for the on farm welfare assessment in dairy cows. *Applied Animal Behaviour Science* 126: 19-26
- Rouha-Mülleder, C., Iben, C., Wagner, E., Laaha, G., Troxler, J. and Waiblinger, S., 2009: Relative importance of factors influencing the prevalence of lameness in Austrian cubicle loose-housed dairy cows. *Preventive Veterinary Medicine* 92: 123-133.
- Redbo, I. and Nordblad, A., 1997. Stereotypies in heifers are affected by feeding regime. *Applied Animal Behaviour Science* 53: 193-202.
- Rehn, H., Berglund, B., Phillipsson, J., Emanuelson, U. and Tengroth, G., 2000. Breed and management interaction for production and reproduction in Swedish dairy cows. *Acta Agriculturae Scandinavica* 50: 137-145.
- Rind, M.I. and Phillips, C.J.C., 1999. The effects of group size on the ingestive and social behaviour of grazing dairy cows. *Animal Science* 68: 589-596.
- Sambras, H.H., 1969. Das soziale Lecken des Rindes. (Social licking in cattle: in German). *Zeitschrift für Tierpsychologie* 26: 805-810.
- Sato, S. and Kuroda, K., 1993. Behavioural characteristics of artificially reared calves. *Animal Science Technology* 64: 593-598.
- Sato, S. Sako, S. and Maeda, A., 1991. Social licking patterns in cattle (*Bos taurus*): influence of environmental and social factors. *Applied Animal Behaviour Science* 32: 3-12.
- Sato, S. Tarumizu, K. and Hatae, K., 1993. The influence of social factors on allogrooming in cows. *Applied Animal Behaviour Science* 38: 235-244.
- Schaik van, G. Dijkhuizen, A.A. Huirne, R.B.M. Schukken, Y.H. Nielen, M. and Hage, H.J, 1998. Risk factors for existence of bovine herpes virus 1 antibodies on non-vaccinating Dutch dairy farms. *Preventive Veterinary Medicine* 34: 125-136.

## 2. A review of the impact of housing on dairy cow behaviour, health and welfare

- Schofield, S.A., Phillips, C.J.C. and Owens, A.R., 1991. Variation in the milk production, activity rate and electrical impedance of cervical mucus over the oestrous period of dairy cows. *Animal Reproduction Science* 24: 231-248.
- Silanikove, N., 2000. Effects of heat stress on the welfare of extensively managed domestic ruminants. *Livestock Production Science* 67:1-18.
- Singh, S.S. Ward, W.R. Hughes, J.W. Lautenbach, K. and Murray, R.D., 1994. Behaviour of dairy cows in a straw yard in relation to lameness. *Veterinary Record* 135: 251-253.
- Smits, M.C.J. Frankena, K. Metz, J.H.M. and Noordhuizen, J.P.T.M., 1992. Prevalence of digital disorders in permanent housing dairy cows. *Livestock Production Science* 32: 231-244.
- Solen, J., 2002. Hond verspreider van neospora. (The spreading of Neosporosis by dogs). *Overijssels dagblad*, 03-04-02 [in Dutch].
- Somers, J.G., C.J. Noordhuizen-Stassen, E.N. Frankena, K. and Metz, J.H.M., 2001. Epidemiological study on claw disorders in dairy cattle: impact of floor systems. In: *Proceedings of the 12<sup>th</sup> Int. Symposium on Lameness in Ruminants*, 9-13 January 2002, Orlando, Florida, USA, pp. 350-354.
- Somers, J.G., Frankena, K., Noordhuizen-Stassen, E.N. and Metz, J.H.M., 2003. Prevalence of claw disorders in Dutch dairy cows exposed to several floor systems. *Journal of Dairy Science* 86: 2082-2093.
- Sommer, T., 1985. Untersuchungen zur Tiergerechtigkeit praxisüblicher Gestaltung von Laufflächen für Milchvieh im Boxenlaufstall. (Research into the animal welfare implications of cubicle house floors for dairy cattle: in German) *Liz. Arbeit, Zool. Institut, Bern, Switzerland*.
- Sonck, B., Daelemans, J. and Langenakens, J., 1999. Preference test for free stall surface material for dairy cows. *Proceedings of the ASAE Ann. Int. Meeting*, July 18-21, Toronto, Canada. Paper no. 994011.
- Telezhenko, E., Lidfors, L. and Bergsten, C., 2007. Dairy cows' preferences for soft or hard flooring when standing or walking. *Journal of Dairy Science* 90: 3716-3724.
- Thomsen, P.T. Kjeldsen, A.M. Sorensen, J.T. Houe, H. and Ersboll, A.K., 2006. Herd-level risk factors for the mortality of cows in Danish dairy herds. *Veterinary Record* 158: 622-626.
- Underwood, E.J. and Suttle, N.F., 1999. *The Mineral Nutrition of Livestock*. CABI Publishing, Wallingford, UK.
- Vailes, L.D. and Britt, J.H., 1990. Influence of footing surface on mounting and other sexual behaviors of estrual Holstein cows. *Journal of Animal Science* 68: 2333-2339.
- Van den Pol-Van Dasselaar, Corr, W.J., Hopster, H., Van Laarhoven, G.C.P.M. and Rougoor C.W., 2002. Belang van weidegang (Importance of grazing: in Dutch). *Praktijk Rapport Rundvee 14*, Animal Science Group, Wageningen UR Livestock Research, Lelystad, the Netherlands.
- Van Gastelen, S., Westerlaan, B., Houwers D.J. and Van Eerdenburg, F.J., 2011. A study on cow comfort and risk for lameness and mastitis in relation to different types of bedding materials. *Journal of Dairy Science* 94: 4878-4888.
- Vandehede, M., Shehi, R., Nicks, B., Canart, B., Dufrasne, I., Biston, R., and Lecomte, P., 1994. Influence de la pluie sur l'utilisation d'un abri par des taurillons au pâturage. *Annales de Medecine Veterinaire*, 138: 91-94.
- Veissier, I., Capdeville, J. and Delval, E., 2004. Cubicle housing systems for cattle: the comfort of dairy cows depends on cubicle adjustment. *Journal of Animal Science* 82: 3321-3337.
- Veissier, I., Andanson, S., Dubroeuq, H. and Pomiès, D., 2008. The motivation of cows to walk as thwarted by tethering. *Journal of Animal Science* 86: 2723-2729.
- Vermunt, J., 1990. Lesions and structural characteristics of the claws of dairy heifers in two management systems. Ph. D. Thesis, University of Saskatchewan, Canada, p. 332.



- Waiblinger, S., Reichmann, V., Troxler, J., Dreiseitl, H., Haller, J. and Windischbauer, G., 2001. Einfluß eines Vorrückfressgitters auf Druckbelastungen und Schäden an den Schultern von Milchkühen. Institut für Agrartechnik der Universität Hohenheim, p. 462-465.
- Walker, J.W. Heitschmidt, R.K. and Dowhower, S.L., 1985. Evaluation of pedometers for measuring distance travelled by cattle on two grazing systems. *Journal of Range Management* 38: 90-93.
- Washburn, S.P. White, S.L. Green, J.T. and Benson, G.A., 2002. Reproduction, mastitis and body condition of seasonally calved holstein and jersey cows in confinement or pasture systems. *Journal of Dairy Science* 85: 105-111.
- Webb, N.G. and Nilsson, C., 1983. Flooring and injury – an overview. *Current Topics in Veterinary Medicine, and Animal Science*, Martinus Nijhoff, The Hague, the Netherlands, pp. 226-261.
- Webster, A.J., 2002. Effects of housing practices on the development of foot lesions in dairy heifers in early lactation. *Veterinary Record* 151: 9-12.
- Wechsler, B. Schaub, J. Friedli, K. and Hauser, R., 2000. Behaviour and leg injuries in dairy cows kept in cubicle systems with straw bedding or soft lying mats. *Applied Animal Behaviour Science* 69: 189-197.
- Whistance, L.D. Arney, D.R. Sinclair, L.A. and Phillips, C.J.C., 2007. Defecation behaviour of dairy cows housed in straw yards or cubicle systems. *Applied Animal Behaviour Science* 105: 14-25.
- Whistance, L.D. Arney, D.R. Sinclair, L.A. and Phillips, C.J.C., 2011. Eliminative behaviour of dairy cows at pasture. *Applied Animal Behaviour Science* 130: 73-80.
- Whitehead, D., 1995. *Grassland Nitrogen*. CAB International, Wallingford, UK.
- Wiederkehr, T. Friedli, K. Wechsler, B., 2001. Einfluss von regelm.,áigem Auslauf auf das Vorkommen und den Schweregrad von Sprunggelenkssch.,den bei Milchvieh im Anbindestall (The effect of repeated exercise on incidences and severity of hock injuries of dairy cattle in tie-stalls: in German). In: *Aktuelle Arbeiten zur artgemáßen Tierhaltung 2000*. KTBL-Schrift 403, Darmstadt, Germany, pp. 163-170
- Wierenga, H.K., 1984. The social behaviour of dairy cows: some differences between pasture and cubicle system. In: Unshelm, J. Putten van, G. Zeeb, K. (eds.) *Proceedings of the International Congress on Applied Ethology*, Kiel, Germany, pp. 135-138.
- Wierenga, H.K. and Hopster, H., 1990. The significance of cubicles for the behaviour of dairy cows. *Applied Animal Behaviour Science* 26: 309-337.
- Wierenga, H.K., Metz, J.H.M. and Hopster, H., 1985. The effect of extra space on the behaviour of dairy cows kept in a cubicle house. In: Zayan, R. (ed.) *Social space for domestic animals*. Martinus Nijhoff, Dordrecht, the Netherlands, pp. 160-170.
- Wilkinson, J.M., 1999. Silage and animal health. *Natural Toxins* 7: 221-232.

### 3. A cow comfort monitoring scheme to increase the milk yield of a dairy farm

F.J.C.M. van Eerdenburg<sup>1</sup>, S. Vázquez-Flores<sup>2</sup>, J. Saltijeral-Oaxaca<sup>3</sup> and E.N. Sossidou<sup>4</sup>

<sup>1</sup>Dept Farm Animal Health, Fac. Veterinary Medicine, Utrecht University, Yalelaan 7, 3584 CL Utrecht, the Netherlands; <sup>2</sup>Escuela de Biotecnología, Industrias Alimentarias y Agronomía (ESIABA), Tecnológico de Monterrey, campus Querétaro, Epigmenio González No. 500 San Pablo, Querétaro, Querétaro, CP 76220, México; <sup>3</sup>Universidad Autónoma Metropolitana, Departamento de Producción Agrícola y Animal, Calzada del hueso 1100, Col. Villa Quietud, Coyoacan, DF CP 0496, México; <sup>4</sup>Veterinary Research Institute, National Agricultural Research Foundation, P.O. Box 60272, 57001 Thessaloniki, Greece; [F.J.C.M.vaneerdenburg@uu.nl](mailto:F.J.C.M.vaneerdenburg@uu.nl)

#### Abstract

A scoring system for dairy cow comfort in free stall barns is developed that results in a single score for each farm. It consists of animal based parameters as well as environmental aspects, having a variable weight for all parameters, depending on their score. This system has been tested on dairy farms in the Netherlands, Mexico and Greece with a positive correlation between the scores and milk yield. Furthermore, there was a correlation of 0.84 with the Welfare Quality® Assessment Protocol for cattle in the Greek farms.

**Keywords:** dairy cattle, husbandry, animal welfare, management, welfare assessment

#### 3.1. Introduction

Cow comfort receives substantial attention in modern dairy farming. In recent years, there has been substantial criticism regarding the welfare of dairy cattle in intensive production systems. Nonetheless, many farmers continuously try to provide their cows with a comfortable environment in order to increase production without diminishing their health status. A great effort has been made in the past decades to improve cow facilities by introducing technology that has also sustainability benefits (Cozzi *et al.*, 2008; Maga and Murray, 2010). One of the challenges is the understanding of these improvements and changes in animal welfare and the overall impact in a cow's life (Botreau *et al.*, 2007). Up to date, there is no report about the relation between the general level of cow comfort and milk yield (Van Eerdenburg *et al.*, 2009). There have been studies with different approaches, for instance: animal behaviour, physiology, anatomy, health and immunity (McGlone, 2001), or based on facilities and environment (Barnett, 2007; Bewley and Jackson-Smith, 2001). Emphasis has been made on production related parameters such as lameness, water consumption and nutrition (Booth *et al.*, 2004; Botreau *et al.*, 2007; Von Keyserlingk *et al.*, 2009). The health status is a major concern, it can be influenced by the cow-comfort level, but it is also of key importance for the well-being of a cow (Von Keyserlingk *et al.*, 2009). Milk yield is objectively measurable in an easy way, that is why it could be correlated to body condition scoring (Bewley and Schutz, 2008; Roche *et al.*, 2009). Cow comfort, however, is not as easy to assess if one wants an overall score (Fraser, 2003). In the design of a scoring system for cow comfort, several approaches can be chosen (Botreau *et al.*, 2007; Main *et al.*, 2004). One

can look at the cows individually or as a herd, at one moment or over a certain time period, and one can include the environment as well. Furthermore, the time needed for the assessment should not be too long, in order to be applied as a tool in herd management programs. In this chapter, a cow comfort monitoring system is presented that provides an overall score for cow comfort and its relationship with milk yield is determined.

### 3.2. Materials and methods

The scoring system that has been developed is listed and explained in the appendix. The complete scoring system was tested regarding cow, environment and health parameters. Farms were assessed in three countries: the Netherlands (48), Mexico (55) and Greece (36). All the assessments were performed by trained investigators.

In the analysis, the level of milk production was correlated with the total score and with each chapter (Pearson correlation in SPSS 16.0). Because of the different climatic conditions in Mexico, Greece and the Netherlands, the data from each country were treated separately.

#### 3.2.1 Comparison with Welfare Quality Assessment

In order to compare the newly developed system with the Welfare Quality Assessment, the final results of both scoring systems were correlated after conversion to a scale from 1 to 4 (Table 3.1).

### 3.3. Results

The results are presented in Figures 3.1 to 3.3. Mexican and Greek farms scored higher than the Dutch farms:  $227 \pm 57$  and  $216 \pm 97$  vs.  $135 \pm 117$  points resp. (Mean  $\pm$  SD). There was a substantial variation between farms as represented by the SD. The Dutch farms had a correlation of 0.34 ( $P < 0.02$ ) between the number of points scored and the 305 day milk yield (Figure 3.2). Without the health related items the correlation was even higher ( $r = 0.40$ ;  $P < 0.01$ ). A similar trend was observed for the Greek farms in the correlation between milk yield and total score ( $r = 0.31$ ;  $P < 0.08$ ). The Mexican farms had a larger variation and a lower correlation ( $r = 0.13$ ;  $P = 0.35$ ).

The combined health factors were positively correlated with the combined other scored items on the Dutch and Greek farms ( $r = 0.70$ ;  $P < 0.001$ ,  $r = 0.72$ ;  $P < 0.001$ ). On the Mexican farms these were not correlated.

Table 3.1. Total scores converted to a scale from 1 to 4.

	Overall welfare	Total score
1	Not classified	<150
2	Acceptable	150-250
3	Enhanced	250-350
4	Excellent	>350

### 3. A cow comfort monitoring scheme to increase the milk yield of a dairy farm

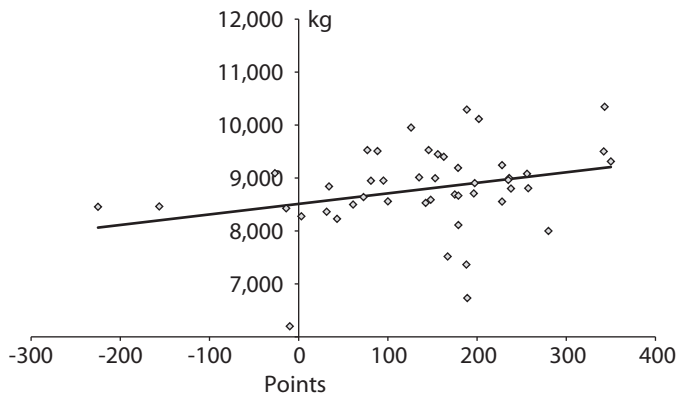

Figure 3.1. Results of 48 farms in the Netherlands. The milk yield (305 day rolling herd average) was correlated with the cow comfort score ( $r=0.34$ ;  $P<0.02$ ).

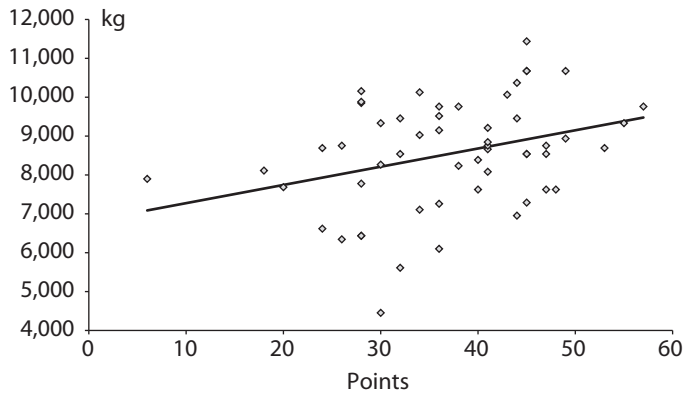

Figure 3.2. Correlation between free stall comfort and milk yield in the Mexican farms ( $r=0.33$ ;  $P<0.02$ ).

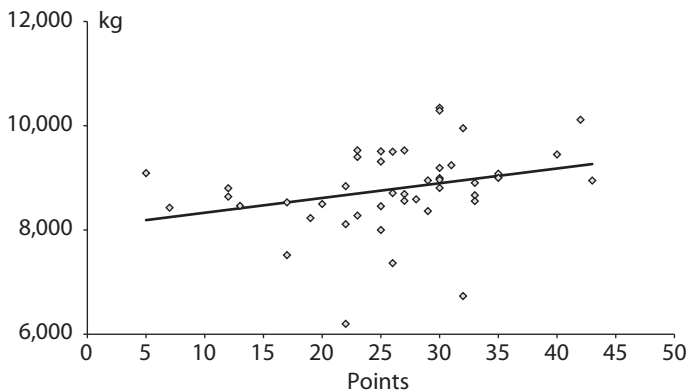

Figure 3.3. Correlation between floor comfort and milk yield in the Dutch farms ( $r=0.29$ ;  $P<0.05$ ).

Several chapters in the scoring system did have a significant correlation with the milk yield level. Examples are presented in Figure 3.2 to 3.3.

Remarkably, the health status of the farms had no correlation with production in the Mexican farms and a low, not significant one, in the Dutch and Greek farms ( $r=0.03$ ;  $P=0.82$  and  $r=0.21$ ;  $P=0.30$ ,  $r=0.27$ ;  $P=0.34$  resp.).

The execution of both systems differed substantially. The cow comfort score system concentrated particularly on the environment of the cow, and the Welfare Quality® protocol examined the condition of many individual cows. This meant that there was a substantial difference in time needed to examine the farms. For instance, by the cow comfort score system more cows are watched at the same time by which an average score is recorded, like cleanliness of the cows. With the Welfare Quality® protocol a substantial percentage of the cows is checked individually, the cleanliness of the lower hind legs, hind quarters and udder is noted by which an average is calculated. But as both systems were used more often, the execution went faster. Nevertheless, time needed for examining differed enormously. On a farm with 100 cows, applying the cow comfort score system lasted an hour and a half, applying the Welfare Quality® protocol took almost 7 hours. The results of both systems had a correlation of 0.84 ( $P<0.01$ ). Scores achieved by the individual farms using the cow comfort score system varied from 55 to 330 points. The overall assessment of the farms with the welfare quality protocol varied from not classified to enhanced. Standing idle was also correlated with the total score of the Welfare Quality protocol ( $r=0.87$ ;  $P<0.01$ ). The item standing idle had a correlation with the total score of the scoring system as well. In the Mexican farms it was 0.43 ( $P<0.01$ ), for the Dutch farms  $r=0.39$  ( $P<0.01$ ) and for the Greek farms 0.42 ( $P<0.01$ ). Without the health related items the correlations were 0.57, 0.50 and 0.53 ( $P<0.001$ ) respectively.

### **3.4. Discussion**

Since there was no general scoring system reported for cow-comfort so far, it had to be developed from scratch. However, after using and adjusting the system in the ambulatory clinic of the Veterinary Faculty of Utrecht for more than two years, it was decided to start the present study. It is a system with limitations, but in the current form these seemed minimal.

The fact that the Mexican and Greek farms scored higher than the Dutch farms ( $227\pm57$  and  $216\pm97$  vs.  $135\pm117$  points) (Mean  $\pm$  SD), can be explained by the fact that the Mexican and Greek farms were selected on the basis that they had to keep records of all diseases and production data. Only the ‘better’ farmers do so, whereas the Dutch farms were selected completely random.

The combined health parameters were not correlated with the milk yield level at the farms, in Mexico, Greece and the Netherlands. This is surprising because it was expected that these would have a substantial impact (Erb *et al.*, 1985; Firat, 1993; Jones *et al.*, 1984). An explanation for this result is not available yet. However, considering the fact that many farmers do not keep proper health records, the value of the obtained data could be disputed. The farmers were asked about the health data of their cows, but when they had no decent records, they gave the figures out of their memory and that was not very reliable. Others might consider it sensitive information and

### 3. A cow comfort monitoring scheme to increase the milk yield of a dairy farm

not be eager to share it. So for this reason, in future studies, one might skip a number of health parameters and only use the ones that can be obtained by the observers themselves.

Cows are highly motivated to maintain lying times of 12 to 13 h/day (Jensen *et al.*, 2005). Lying time can, therefore, be a good indicator for animal welfare or cow comfort (Fregonesi and Leaver, 2001), but it takes a major time investment to measure it. It is therefore that in this system is chosen to evaluate the conditions that are required for lying and known to promote lying in cattle. This is much more practical. Overcrowding is one of the known factors that will reduce lying time (Fregonesi *et al.*, 2007). A comfortable bedding will increase lying time (Herlin, 1997; Hodgson, 1986; Manninen *et al.*, 2002; Palmer and Wagner-Storch, 2003; Rushen *et al.*, 2001; Tucker *et al.*, 2003), but also the size of the free stalls and type of divider are of importance (Gaworski *et al.*, 2003; House *et al.*, 2003; Irish and Merrill, 1986; Lundeen, 2003; McFarland, 2002, 2003; Tillie, 1986; Tucker and Weary, 2001; Tucker *et al.*, 2004, 2005; Weary and Tazskun, 2000). An indication for the lying time can be derived from the number of cows standing idle. This is, however, depending on the time of the day and other factors as well. During lying the blood flow through the udder is 25 to 50% higher and this will result in a higher milk yield (Metcalf *et al.*, 1992). In the present study, a positive correlation was observed between the free stall parameters and milk yield (Figure 3.3).

The scoring system was used by many persons and on many farms. After a short training, all observers could evaluate a farm in less than 1 hour, if the farmer had the historical health data ready. So it is a system that can be implemented in the routine of herd health consultants. Because it is numerical, one can compare the comfort level between farms worldwide. The Welfare Quality® system takes about 1 day for 1 farm and does not result in a numerical score, which makes it more complicated to use in comparative studies. Despite the duration difference in execution, the results of both systems had a correlation of 0.84 ( $P < 0.01$ ). One could save more time by just counting the number of cows standing idle, which is also known as the cow comfort index as proposed by Cook *et al.* (2005). The correlations with the total score were not that high, however. But with the Welfare Quality system it was 0.87 ( $P < 0.01$ ). The extra information obtained by executing the entire protocol of that system is thus costing a great deal of time.

It is important to realize that negative scores weigh more than positive ones, conveying strength to this system. Other systems that evaluate animal welfare status, such as the Animal Needs Index (Ofner *et al.*, 2003) and Welfare Quality®, weigh certain parameters more than others, but never depending on the score of that parameter. However, if a certain aspect of welfare, e.g. food, is negatively scored, this implies that there is a need for that particular aspect. If an animal is hungry, food is the main thing that occupies his/her mind at that moment. The search for food is dominating other needs, like proper bedding or social contact. With a full belly, proper bedding and social contact become, relatively, more important. If a cow has mastitis, she will feel bad. Having access to pasture is less important then since the animal just wants to get rid of the disease. It is therefore that in the presented system a minimum score needs to be acquired for each chapter. If the minimum score is not reached, the difference between the score for that chapter and the minimum is subtracted from the total. This characteristic will allow for this parameter to stand out in comparison with the total score. The use of this scoring system in three different countries, in a wide variety of farms, demonstrate that the scoring system is reproducible and user

friendly in order to assess the welfare status of the cows on a dairy farm. The practical execution of the cow comfort scoring system is substantially less time consuming and easier to perform than the Welfare Quality® assessment protocol.

## **Acknowledgements**

The authors wish to thank all farmers that cooperated in the studies, all the students that participated and specifically: Ilse Baars, Charlotte Eeckelaar, Lenny van Erp, Moniek van Gastel, Aukje Geurtsen, Ingrid Pulles, Monique Tellekamp, Astrid Vriens, and Margriet Wagenaar.

## **References**

- Barnett, J.L., 2007. Effects of confinement and research needs to underpin welfare standards. *Journal of Veterinary Behavior: Clinical Applications and Research* 2: 213-218.
- Bewley, J.P.R. and Jackson-Smith, D.B., 2001. A comparison of free-stall barns used by modernized Wisconsin dairies. *Journal of Dairy Science* 84: 528-541.
- Bewley, J.M. and Schutz, M.M., 2008. Review: an interdisciplinary review of body condition scoring for dairy cattle. *The Professional Animal Scientist* 24: 507-529.
- Booth, C., Warnick, L.D., Gröhn, Y., Maizon, D.O., Guard, C.L. and Janseen, D., 2004. Effect of lameness on culling in dairy cows. *Journal of Dairy Science* 87: 4115-4122.
- Botreau, R., Butterworth, B.M., Perny, A., Bracke, M.B.M., Capdeville, J. and Veissier, I., 2007. Aggregation of measures to produce an overall assessment of animal welfare. Part 1: a review of existing methods. *Animal* 1: 1179-1187.
- Cozzi, G., Brscic, M. and Gottardo, F., 2008. Animal Welfare as a pillar of a sustainable farm animal production. *Acta Agricultura Slovenica (supl. 2)*: 23-31.
- Chastain, J., 2000. Lighting in freestall barns. Dairy housing and equipment systems. PALS. Camp Hill, PA, USA, pp. 115-130.
- Cook, N.B., Bennett, T.B. and Nordlund, K.V., 2005. Monitoring indices of cow comfort in free-stall-housed dairy herds. *Journal of Dairy Science* 88: 3876-3885.
- Dahl, G.E., Buchanan B.A. and Tucker, H.A., 2000. Photoperiodic effects on dairy cattle: a review. *Journal of Dairy Science* 83(4): 885-893.
- Erb, H.N., Smith, R.D., Oltenacu, P.A., Guard, C.L., Hillman, R.B., Powers, P.A., Smith, M.C. and White, M.E., 1985. Path model of reproductive disorders and performance, milk fever, mastitis, milk yield, and culling in Holstein cows. *Journal of Dairy Science* 68: 3337-3349.
- Firat, M.Z., 1993. An investigation into the effects of clinical mastitis on milk yield in dairy cows. *Livestock Production Science* 36: 311-321.
- Fraser, D., 2003. Assessing animal welfare at the farm and group level: the interplay of science and values. *Animal Welfare* 12: 433-443.
- Fregonesi, J., Tucker, C.B. and Weary, D.M., 2007. Overstocking reduces lying time in dairy cows. *Journal of Dairy Science* 90: 3349-3354.
- Fregonesi, J.A. and Leaver, J.D., 2001. Behaviour, performance and health indicators of welfare for dairy cows housed in strawyard or cubicle systems. *Livestock Production Science* 68: 205-216.
- Gaworski, M.A., Tucker, C.B., Weary, D.M. and Swift, M.L., 2003. Effects of stall design on dairy cattle behaviour. Fifth International Dairy Housing Conference, Forth Worth, Texas, USA, American Society of Agricultural Engineers. pp 139-146.

### 3. A cow comfort monitoring scheme to increase the milk yield of a dairy farm

- Grandin, T., 1997. Adapting bovine behavior to improve performance. In: Kennelly, E.J. (ed.) *Advances in Dairy Technology*. Western Canadian Dairy Seminar, University of Alberta, Alberta, Canada. 9: 365-379.
- Hall, S., Vince, M.A., Shilito-Walser, E. and Garson, P.J., 1988. Vocalisations of the Chillingham cattle. *Behavior* 104: 78-104.
- Herlin, A., 1997. Comparison of lying area surfaces for dairy cows by preference, hygiene and lying down behaviour. *Swedish Journal of Agricultural Research* 27: 189-196.
- Hodgson, A.S., 1986. Surface materials for free stalls. Dairy freestall housing symposium. Northeast Regional Agricultural Engineering Service, Harrisburg, PA, USA.
- House, H.K., Rodenburg, J. and Lang, B.R., 2003. The effect of neck rail and mounting rail position on cow behavior. Fifth International Dairy Housing Conference, Fort Worth, Texas, USA, American Society of Agricultural Engineers. pp 147-154.
- Irish, W.W. and Merrill, W.G., 1986. Design parameters for freestalls. Dairy Freestall Housing Symposium, Northeast Regional Agricultural Engineering Service, Harrisburg, PA, USA.
- Jensen, M.B., Pedersen, L.J. and Munksgaard, L., 2005. The effect of reward duration on demand functions for rest in dairy heifers and lying requirements as measured by demand functions. *Applied Animal Behavior Science* 90: 207-217.
- Jones, G.M., Pearson, R.E., Clabaugh, G.A. and Heald, C.W., 1984. Relationships between somatic cell counts and milk production. *Journal of Dairy Science* 67: 1823-1831.
- Kadzere, C., Murphy, M.R., Silanikove, N. and Maltz, E., 2002. Heat stress in lactating dairy cows: a review. *Livestock Production Science* 77: 59-91.
- Lange, J.L., Thorne, P.S. and Kullman, G.J., 1997. Determinants of viable bioaerosol concentrations in dairy barns *Annals Agricultural and Environmental Medicine* 4: 187-194.
- Lundeen, T., 2003. Measures of cow comfort may improve with facility design. *Feedstuffs*(June 9): 8.
- Maga, E.A. and Murray, J.D., 2010. Welfare applications of genetically engineered animals for use in agriculture. *Journal of Animal Science* 88: 1588-1591.
- Main, D.C.J., Whay, H.R., Hovi, M. and Webster, A.J.F., 2004. Bristol welfare assurance programme: animal based assessment tool for farm animal welfare certification. Bristol Welfare Assurance Programme. University of Bristol, UK.
- Manninen, E., De Passille, A.M., Rushen, J., Norring, M. and Saloniemi, H., 2002. Preferences of dairy cows kept in unheated buildings for different kind of cubicle flooring. *Applied Animal Behavior Science* 75: 281-292.
- McFarland, D.F. and Graves, R.E., 1995. A case study with dairy cattle: freestalls. *Animal behavior and the design of livestock and poultry systems*. Indianapolis, Indiana, USA, Northeast Regional Agricultural Engineering Service. Vol. 84: 277-293.
- McFarland, D. F., 2002. Comfortable free stalls: what's the secret? *Hoards Dairyman* August 10: 516.
- McFarland, D.F., 2003. Freestall design: cow recommended refinements. Fifth International Dairy Housing Conference, Fort Worth, Texas, USA, American Society of Agricultural Engineers.
- McGlone, J.J., 2001. Farm animal welfare in the context of other society issues: toward sustainable systems. *Livestock Production Science* 72: 75-81.
- Metcalf, J.A., Roberts, S.J. and Sutton, J.D., 1992. Variations in blood flow to and from the bovine mammary gland measured using transit time ultrasound and dye dilution. *Research in Veterinary Science* 53: 59-63.



- Ofner, E., Amon, T., Lins, M. and Amon, B., 2003. Correlations between the results of animal welfare assessments by the TGI 35 L Austrian animal needs index and health and behavioural parameters of cattle. *Animal Welfare* 12: 571-578.
- Palmer, R.W. and Wagner-Storch, A.M., 2003. Cow preference for different freestall bases in pens with different stocking rates. Fifth International Dairy Housing Conference, Fort Worth, Texas, USA, American Society of Agricultural Engineers.
- Roche, J.R., Friggens, N.C. Kay, J.K., Fisher, M.W., Stafford, K.J., Berry, D.P., 2009. Invited review: Body condition score and its association with dairy cow productivity, health, and welfare. *Journal of Dairy Science* 92: 5769-5801.
- Rushen, J., De Passille, A.M.B. Haley, D.B., Manninen, E. and Saloniemi, H., 2001. Using behavioural indicators and injury scores to assess the effect of stall flooring on cow comfort. In: Stowell, R.R., Bucklin, R. and Bottcher, M., (eds.) 6<sup>th</sup> Int Symp Livestock Environment, American Society of Agricultural Engineers Louisville, KY, USA, pp. 716-723.
- Tillie, M., 1986. Design of free stall partitions and the welfare of animals. Dairy Freestall Housing Symposium, Northeast Regional Agricultural Engineering Service, Harrisburg, PA, USA.
- Tucker, C.B. and Weary, D.M., 2001. Cow comfort and free-stall design. Ontario Dairy Symposium, Toronto, Canada.
- Tucker, C.B., Weary, D.M. and Fraser, D., 2003. Effects of three types of free-stall surfaces on preferences and stall usage by dairy cows. *Journal of Dairy Science* 86(2): 521-529.
- Tucker, C.B., Weary, D.M. and Fraser, D., 2004. Free-stall dimensions: effects on preference and stall usage. *Journal of Dairy Science* 87: 1208-1216.
- Tucker, C.B., Weary, D.M. and Fraser, D., 2005. Influence of neck-rail placement on free-stall preference, use, and cleanliness. *Journal of Dairy Science* 88: 2730-2737.
- Van Eerdenburg, F.J.C.M., Plekkenpol, S.J., Saltijeral-Oaxaca, J. and Vázquez Flores, S., 2009. Aumento de la producción láctea mejorando el bienestar de la vaca y reduciendo el estrés calórico. XXXVII Jornadas Uruguayas de Buiatría Paysandú, Uruguay, pp 34-43.
- Veissier, I., Capdeville, J. and Delval, E., 2004. Cubicle housing systems for cattle: comfort of dairy cows depends on cubicle adjustment. *Journal of Animal Science* 82: 3321-3337.
- Von Keyserlingk, M.A.G., Rushen, J., De Passillé, A.M. and Weary, D.M., 2009. Invited review: the welfare of dairy cattle – key concepts and the role of science. *Journal of Dairy Science* 92: 4101-4111.
- Weary, D. M. and Tazskun, I., 2000. Hock lesions and free-stall design. *Journal of Dairy Science* 83: 697-702.
- Wheeler, E., Graves, R.E., Zajackowski, J.L., Tyson J.T., McFarland, D.F., Richie, P., 2001. Protocol for determination of environmental parameters in animal housing. In: Stowell, R.R., Bucklin, R. and Bottcher, M. (eds.) 6<sup>th</sup> Int. symposium on Livestock Environment, American Society of Agricultural Engineers, Louisville, KY, USA., pp. 359-366.

### 3. A cow comfort monitoring scheme to increase the milk yield of a dairy farm

#### Appendix. Score for cow comfort on the dairy farm<sup>2</sup>

This scoring system is specifically designed for barns with free stalls. Table 3.A1 summarizes the various items of interest for cow comfort at farm level, on dairy farms, with the number of points that can be acquired. Indications for the points can be found in the explanation. If the range is e.g. 0-15 points, all numbers of points in between can be given as well. The points can be summed per chapter and totalled for the entire farm. If the minimum score for a chapter is not reached, the difference between the score and the minimum needs to be subtracted from the score. (Example: if for the chapter *General* a total of 8 points is scored, 2 points need to be subtracted, because the minimum score is 10. The score for *General* will thus be 6). The scoring should be done at least one hour before or after milking, when the cows are at rest.

Table 3.A1. Scoring system for comfort of dairy cows.

	Minimum	Maximum
General	10	20
- Percentage of cows standing idle		0 (-100)
- Fear behaviour		5
- Stretching when raising from cubicle		3
- Tail is hanging straight and relaxed		3
- Bellowing		4
- Cows lying in walkways		5 (-10)
- Noise (environmental)		0 (-5)
Light	10	25
- Sufficient light in the barn		10
- Period of light		15
Ventilation	30	50
- It smells fresh (between the animals)		5
- Cobwebs		10
- Condense / mold		10
- Barn temperature		10
- Dead spaces		5
- Draft		10
Cubicles / free stalls	40	70
- Cows are clean		5
- Bedding is made of inorganic material		5
- Bedding is soft		10 (-10)
- Bedding is clean and dry		10
- Stall surface is under a slight angle		5
- Bedding is flat		5 (-5)

<sup>2</sup> An Excel sheet with formulas can be obtained via email: [F.J.C.M.vanEerdenburg@uu.nl](mailto:F.J.C.M.vanEerdenburg@uu.nl).

	Minimum	Maximum
- Neck rail		5
- Lunge space		10
- Stall dimensions		10
- Brisket board		5
- Number		0 (-10)
Floor	20	45
- Slipperiness		10
- Loose / unequal slats		10
- Rubber		10
- Walking		10
- Cleanliness		5
Feeding fence	6	15
- Headlocks		5
- Height		3
- Number of places		7
- Contamination		(-3)
Concentrate dispenser	0	7
- Number		5
- Type		2
Water	15	25
- Number of places		10
- Type of waterer		5
- Cleanliness		5
- Temperature		5
Waiting room and milking parlour	2	5
- Behaviour		3
- Time		2
Walkways and alleys	3	5
- Width of the alley behind the feeding fence		2 (-2)
- Width other walkways		2
- Sufficient passages		1
Miscellaneous	10	40
- Maternity pen		3
- Sick bay		2
- Access to pasture / outside paddock		20
- Is there a mechanical brush?		15
Animal health + feeding	100	200
- Hair		5
- Lameness		25 (-25)
- Hocks		20 (-60)
- Carpus		20 (-60)
- Claws		20
- Mastitis		15 (-15)

### 3. A cow comfort monitoring scheme to increase the milk yield of a dairy farm

---

	Minimum	Maximum
- Abomasal displacement		10 (-15)
- Filling of the rumen		5 (-10)
- Milking fever		5 (-10)
- Acetonaemia (ketosis)		5 (-15)
- BCS		15
- Fat %		15
- Fertility		25 (-10)
- Calving		15

---

#### **Explanation**

If the range, given after the item title, is e.g. 0-15 points, all numbers of points in between can be given as well. The numbers presented below are indications and other values can be used if the situation does not match the descriptions given. The scoring was based on available reports and experience of the authors and was evaluated extensively in practice over four years.

#### **General**

- Percentage of cows standing idle (-100-0 points)  
Cows should only be standing when they eat or drink and should be lying down after eating. Therefore, the number of cows standing in walkways or in their cubicles is, a good 'comfort-indicator' (Cook *et al.*, 2005). Cows that are waiting in front of the concentrate dispenser, however, are not standing idle, they wait. Count this parameter as the first thing to do when you enter the barn. For each percentage of cows that are standing idle during a quiet period of the day (i.e. >1 h before or after milking): -1 point
- Fear behaviour (0-5 points)  
Cows show you when they are treated well by the farmer. If the cows remain quiet when you enter the barn, make no sudden movements when you get closer and if they do not look scared: give 3 points. For scared animals: 0 points. If the animals approach you quickly (curiously): 5 points.
- Stretching when rising from cubicle (0-3 points)  
If a cow lies comfortably, she will stretch before she leaves the cubicle. If she does so: 3 points; otherwise: 0 points. Wait for spontaneously rising cows.
- Tail is hanging straight and relaxed (0-3 points)  
Stressed cows do not have a relaxed tail. Excited animals can keep their tail straight up, but this can be seen as an expression of very positive welfare. There can be a lot of moving tails due to flies. This is impairing the comfort of the cows. If >90% of the cows have a relaxed, straight tail: 3 points. When you see this in 80-90% of the animals: 2 points, otherwise: 0 points.
- Bellowing (0-4 points)  
Vocalizations are not common among cows and represent unrest (Hall *et al.*, 1988). Animals in oestrus or with cystic ovarian follicle condition will bellow often. When there are no such

cows present or there are less than twice per 30 min: 4 points; twice per 30 min: 2 points, if there is more bellowing than two times per 30 min: 0 points.

- Cows lying in walkways (-10-5 points)  
Cows should not lie in the walkways. If they do not: 5 points. If there are around 1% of the cows doing so: 0 points; 5% or more: -10 points.
- Noise (-5-0 points)  
Cows do not like noise in their environment (Grandin, 1997). If there is a lot of noise from tractors, shouting, etc. give: -5 points. Some noise: -3 points. Quiet situation: 0 points.

### *Light*

- Sufficient light in the barn (0-10 points)  
One should be able to read a newspaper easily anywhere in the barn (Chastain, 2000). When the light intensity is measured it should be >100 lux. If so: 10 points. When there is a moderate level of intensity, or not >100 lux in all places: 5 points. When the level is low or there is bad sight in several places: 0 points.
- Period of light (0-15 points)  
When the photoperiod is long, cows feel better and produce more milk (Dahl *et al.*, 2000). However, rest is also important for cattle. A period of darkness (lights out) needs to be included in the daily routine as well (Dahl *et al.*, 2000). Therefore, if the period of light is >21 h: 0 points; 20 h: 2 points; 19 h: 5 points; 18 h: 7 points, 17 h: 10 points; 16 h: 15 points; 15 h: 12 points; 14 h: 8 points; 13 h: 5 points; 12 h: 3 points; 11 h: 2 points and ≤10 h: 0 points.

### *Ventilation*

- It smells fresh (0-5 points)  
It should not smell like NH<sub>3</sub>, H<sub>2</sub>S, or other toxic gasses inside the stables (Kangas *et al.*, 1987). If the smell is strong: 0 points; not so fresh: 2 points. When there is a fresh, pleasant air: 5 points. This is a parameter for air quality around the animals, so it should be measured there and not before the feeding fence (Wheeler *et al.*, 2001).
- Cobwebs (0-10 points)  
Cobwebs are seen at places with low airflow. If there are many cobwebs visible: 0 points; a few: 5 points; rare or none: 10 points.
- Condense/mold (0-10 points)  
Water condensation along the ceiling or wall is an indication that the relative humidity is too high. If this occurs often, fungi will start to grow on the ceiling and walls. A high humidity causes difficulties for thermoregulation (Kadzere *et al.*, 2002) and increases the risk for droplet infections (Lange *et al.*, 1997). If you see heavy condensation or mold growth: 0 points; Dry, clean walls and ceilings: 10 points.
- Barn temperature (0-10 points)  
The barn temperature is important for cows. However, it is a complicated feature to score. The temperature varies during the day and season, and cows adapt to high temperatures if they are in a hot environment for a prolonged period of time (or their entire life). It is, therefore, impossible to give a fixed number or ratio for the scoring system to use worldwide. The barn

### 3. A cow comfort monitoring scheme to increase the milk yield of a dairy farm

temperature also reflects the result and quality of the ventilation. Guidelines for the scoring are presented below.

- For moderate and cool climate zones (e.g. the Netherlands or Scandinavian countries):  
During summer the barn should be cooler than outside:  
Difference is 1-5 °C: 5 points; >5 °C: 10 points. If the barn temperature is 25-30 °C, subtract 1-5 points; >30 °C, subtract 5-10 points.  
In winter there should not be a big difference between inside and outside:  
Difference is 0-2 °C: 10 points; 2-5 °C: 5 points; >5 °C: 0 points.
- For hot climate zones (e.g. Mexico or Israel):  
If cows have access to shade during the day: 5 points. If there is cooling equipment: 1-5 points more, depending on the number and quality of the cooling system. If cows are suffering from heat stress: -5 points.
- Dead spaces (0-5 points)  
There should not be places in the barn that are not or poorly ventilated. If there are a number of dead spaces: 0 points; with a very small one or none: 5 points.
- Drop of cold air/draft (0-10 points)  
There shouldn't be any draft or drop of cold air in the barn, as this will stress the cows. If there is a lot of draft: 0 points; only in a corner or small part of the barn: 5 points; nowhere: 10 points.

#### *Free stalls/cubicles*

- Cows are clean (0-5 points):  
From clean to dirty: give 5-0 points.
- Bedding is made of inorganic material (0-5 points):  
If the bedding is made of sand or another inorganic, draining, non-absorbing, material: 5 points, else 0. Concrete is also inorganic, but not draining, so: 0 points.
- Bedding is soft (10 points (or -10))  
Perform the knee test (McFarland and Graves, 1995). Good result: 10 points; moderate: 5 points; painful 0 points. If there is no bedding (i.e. hard concrete) do not perform a knee test! -10 points.
- Bedding is clean/dry (0-10 points)  
Cows do not like a wet surface to lie on (Fregonesi *et al.*, 2007). Clean and dry cubicles: 10 points; 30% dirty cubicles: 5 points; >50% dirty cubicles: 0 points.
- Cubicle surface is under a slight angle (0-5 points)  
The angle should be between 3 and 7°. (Not relevant for thick layers of sawdust or sand: give 5 points).
- Bedding is flat (-5-5 points)  
Nice and smooth surface: 5 points. If there is an object popping out though the bedding (e.g. car tires) or when there are large holes and an irregular surface: -5 points.
- Withers bar (neck rail) (0-5 points)  
If the withers bar is not shiny in >95% of the cubicles: 5 points. If it is shiny in 5-20% of the cubicles: 3 points. When >20% of the cubicles has a shiny withers bar: 0 points.

- Lunge space (0-10 points)  
Lunge space is needed by the cow in order to lie down and rise properly (Veissier *et al.* 2004). If there is not enough space to lunge forward, cows may rise as a horse. If there is ample lunge space: 10 points. Less, but still usable lunge space: 5 points. No lunge space: 0 points.
- Stall dimensions (10 points)  
Cubicles need to be of the right size (Veissier *et al.*, 2004). This is dependent on the size of the cows (Table 3.A2 and Figure 3.A1). For the average Dutch HF cattle this means: for wall-side rows: 280×125 cm; double (head to head) or inside (with an open head side) rows: 250×125 cm. If the size meets the need of the cow 10 points; a bit too small: 5 points; too small: 0 points.

Table 3.A2. Free stall dimensions related to Figure 3.A1.

Dimension and location	Animal dimension
1. Width centre to centre of partitions	twice hip width
2. Distance rear of curb to neck rail	body length (rear of pin bones to brisket)
3. Distance rear curb to open front	1-1¼ body length
4. Distance rear curb to closed front	1-1½ body length
5. Clearance rear of curb to rear of partition	at paunch height, ½ hip width or less
6. Height stall bed to neck rail	¾-⅘ shoulder height
7. Clearance beneath side rails for legs and to block hips	¾ hip width
8. Clearance between rails for head (lunge) space	hip width

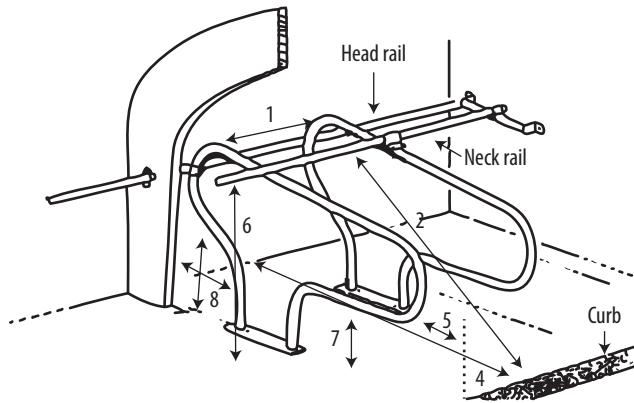

Figure 3.A1. Free stall dimensions in relation to cow size (Irish and Merrill, 1986).

### 3. A cow comfort monitoring scheme to increase the milk yield of a dairy farm

- Brisket board (5 points)  
No brisket board: 5 points; Smooth, rounded rubber tube: 2 points; hard rough wooden board: 0 points. If there is a tube hanging on two chains ('variable brisket board'): 5 points.
- Number (-10 points)  
If the number of cubicles is equal to, or more than, the number of cows: 0 points. With 10% more cows than cubicles: -5 points; If there is 20% or more overcrowding: -10 points.

#### *Floor*

- Slipperiness (10 points)  
The floor should provide sufficient grip: 10 points. If slippery: 0 points.
- Loose/unequal slats or unequal floor (10 points)  
If there are many loose slats and/or slats with rough edges: 0 points; for a smooth floor: 10 points. For a solid floor the same applies.
- Rubber (10 points)  
If >50% of the floor is covered with rubber: 10 points; 25-50%: 7 points; 10-25%: 5 points.
- Walking (10 points)  
If the cows walk with a firm stride: 10 points; if they walk cautious or slow: 0 points.
- Cleanliness (5 points)  
Clean floor: 5 points; Dirty floor: 0 points. In case of an extremely dirty floor: -5 points.

#### *Feeding fence*

- Head gates (5 points):  
With head gates: 0 points. A wooden beam: 3 points. Only a metal rail or tube, without head gates: 5 points.
- Height (3 point)  
The height should be adequate for the cows present, if so: 3 points. If not (trauma at the neck of several cows): 0 points. And in between: 1 or 2 points.
- Number of places (7 points)  
The number of feeding places should at least be the same as the number of cows: 7 points. When there is 10% overcrowding: 3 points. When there is 20% overcrowding: 0 points. With automatic milking systems (milking robot), the need for places at the feeding fence is lower. 20% less than the number of cows is acceptable (3 points) (65 cm of space on a simple fence is one place for a cow).
- Contamination of food (-3 points)  
If food contains any undesirable debris it may affect the cow's health and comfort (wires, plastic containers, etc.); food must be free of any inorganic objects and look suitable for cows. If the food looks 'good': 0 points; if it looks 'bad': -3 points.



*Concentrate dispensers*

- Number (5 points)  
The number should be adequate. This implies: 1 dispenser for a maximum of 25 cows. Then: 0 points. If there is 1 dispenser per 20 cows or less: 5 points, subtract 1 point per cow more than 25 cows per dispenser. If there are no concentrate dispensers give 5 points.
- Type (2 points)  
If the dispenser has closed sides and/or a gate that closes when the cows get concentrate add 2 points. If there are no concentrate dispensers give 2 points.

*Water*

- Number of waterers (10 points)  
There should be 1 drinking space available for every 10 cows. (65 cm of space on a large waterer is 1 drinking place). There should be at least 2 different drinking locations in the barn because of dominant cows. If these conditions are met: 10 points. (If there is no water available in a broken waterer, it is not a waterer).
- Type (5 points)  
A large waterer: 5 points; small waterers: 0 points.
- Cleanliness (5 points)  
If the water is clean: 5 points; dirty 'soup': 0 points.
- Temperature (5 points)  
Lukewarm water (15-25 °C): 5 points; cold water: 0 points.

*Waiting room and milking parlour*

- Behaviour (3 points)  
Quiet cows: 3 points; restless, stressed cows: 0 points.
- Time (2 points)  
Are there any cows that have to wait >1 h. before being milked? Yes: 0 points; No: 2 points.

*Alleys and walkways*

- Width of the walkway behind the feeding fence (-2-2 points)  
This walkway should be wide enough to let two cows pass in opposite directions behind an eating cow. This is, in general, 4 m. >4 m: 2 points; 3.75-4 m: 1 point; 3.5-3.75 m: 0 points; <3.5 m: -2 points.
- Width other walkways and alleys (2 points)  
These paths need to be >3 m wide. If so: 2 points; 2.5-3 m: 1 point; <2.5 m, 0 points.
- Sufficient passages (1 point)  
Cows need to be able to cross cubicle rows easily. They must not have to walk for more than 15 cubicles. One passage per 10-15 cubicles: 1 point; >15: 0 points. (If not applicable, this item can be given the full score of 1 point).

### 3. A cow comfort monitoring scheme to increase the milk yield of a dairy farm

#### *Miscellaneous*

- Maternity pen (3 points)  
The maternity pen is an important place, but the cows are usually there for a short period only. Therefore, the number of points is not that high. There are a number of parameters that are important for the comfort of the pen. See the chapter about the maternity pen for the details. This here is just a guideline for the evaluation:
  - contact with other cows (no physical contact);
  - ample bedding (straw);
  - clean;
  - enough space.
- Sick bay (2 points)  
As for the maternity pen, just a few guidelines here:
  - contact with other cows (no physical contact);
  - ample bedding (straw);
  - clean;
  - enough space.
- Access to pasture/outside paddock (20 points)  
Do the cows have access to pasture?
  - at all times;
  - during the summer: day and night?
  - during the summer at night;
  - is it mandatory or voluntarily?Do the cows have shade in the pasture during hot summer days?  
What is the quality of the pasture?
- Is there a (motorized) brush? (15 points)  
If there is a brush: 5 points. If there is a motorized brush: 15 points.

#### *Animal (health & feeding)*

Animal health and feeding are items that mostly need to be derived from the records of the farmer. In practice, this is, however, a complex matter. Many farmers do not keep proper records and they can, therefore, not be used. To use educated guesses is an option, but very unreliable. It is better to not implement this part if there are no records.

- Hair (5 points)  
Shaved/not shaved; hair that is upright; shiny; lesions; etc.
- Lameness (-25-25 points)  
Here cow-cases per year are indicated. Do not count repeated cases twice:
  - >80% per year → -25 points;
  - 60-80% per year → -20 points;
  - 40-60% per year → -15 points;
  - 25-40% per year → -10 points;
  - 15-25% per year → 0 points;
  - 10-15% per year → 10 points;
  - <10% per year → 25 points.

- Thick hocks (-60-20 points):

A hock can be thicker through bone formation. In such cases the cow is not harmed clinically at that moment. The thickness is mostly caused by repeated trauma and an indication for reduced lying comfort.

- >80% per year → -10 points;
- 60-80% per year → -8 points;
- 40-60% per year → -5 points;
- 25-40% per year → -2 points;
- 15-25% per year → 0 points;
- 10-15% per year → 5 points;
- <10% per year → 10 points.

The hock can also be thicker with soft 'tissue'. If the entire leg is swollen, count this case as 5 cows.

- >80% per year → -50 points;
- 60-80% per year → -40 points;
- 40-60% per year → -30 points;
- 25-40% per year → -20 points;
- 15-25% per year → -10 points;
- 10-15% per year → 0 points;
- 5-10% per year → 5 points;
- <5% per year → 10 points.

If erosions are visible in >50% of the hocks: -10 points; in 25-50%: -5 points; in <25%: no extra withdrawal of points.

- Thick carpi (-60-20 points)

The carpus can be thicker with soft 'tissue'. If the entire leg is swollen, count this cow as 5 cows.

- >80% per year → -50 points;
- 60-80% per year → -40 points;
- 40-60% per year → -30 points;
- 25-40% per year → -20 points;
- 15-25% per year → -10 points;
- 10-15% per year → 0 points;
- 5-10% per year → 10 points;
- <5% per year → 20 points.

If erosions are visible in >50% of the carpi: -10 points, at 25-50%, -5 points, at <25% no extra withdrawal of points.

- Claws (20 points)

Look at form, angle and standing position of the claws (perfect claws: 20 points; poor ones: 0 points). When there are serious problems, the cows will be lame (So you have to score them for this as well). In general, cows with painful claws will be treated and therefore, most cows will not have painful claws during the assessment. Observe 10% of the cows and make an average score.

- Mastitis (-15-15 points)

Take the number of cow-cases per year into account. If a cow is considered healthy and reoccurs after 14 days as a clinical case, then consider as a new case.

### 3. A cow comfort monitoring scheme to increase the milk yield of a dairy farm

- >80% per year → -15 points;
- 60-80% per year → -10 points;
- 40-60% per year → -5 points;
- 25-40% per year → -3 points;
- 15-25% per year → 0 points;
- 10-15% per year → 5 points;
- 5-10% per year → 10 points;
- <5% per year → 15 points.
- Abomasal dislocations (-15-10 points)
  - >15% per year → -15 points
  - 10-15% per year → -10 points
  - 5-10% per year → -5 points
  - 0-5% per year → 0 points
  - 0% per year → 10 points
- Filling of the rumen (-10-5 points)

What is the general impression of all cows? Sample 3 cows of each lactation stage:

  - bad: -10 points;
  - sufficient: 0 points;
  - good: 5 points.
- Milk fever (-10-5 points)
  - >15% per year → -10 points;
  - 10-15% per year → -5 points;
  - 5-10% per year → -2 points;
  - 0-5% per year → 0 points;
  - 0% per year → 5 points.

Cases in cows <4 years → count these double.
- Acetonaemia (ketosis) (-15-5 points)
  - >15% per year → -15 points;
  - 10-15% per year → -10 points;
  - 5-10% per year → -5 points;
  - 0-5% per year → 0 points;
  - 0% per year → 5 points.
- Body Condition Score (15 points)

Calculate the average BCS for the dry cows over a year. They represent the result of the previous lactation and provide an indication of the level of Negative Energy Balance (NEB) postpartum. When the BCS is determined and the average is equal to the desired score: 15 points. For deviations of 0.5 points (up or down): 5 points reduction. If the deviation is ≥1 point: 0 points. When not determined regularly, the BCS can be determined in a random sample of 5 dry cows. The desired score may vary per country and breed.
- Fat % in the milk (15 points)

Calculate the average fat percentage in the milk for the first 3 weeks of lactation. Compare this with the average percentage for the breed and the country (NL=4.8%). If the percentage on the farm differs >1%: 0 points; 0.5-1%: 7 points; <0.5%: 15 points.

- Fertility (-10-25 points)  
What is the impression of the fertility after working out the various indices? Good: 25 points; reasonable: 15 points; poor: -5 points; bad: -10 points.
- Calving (15 points):  
% of cases that needed assistance of the veterinarian:
  - >15% per year → 0 points;
  - 10-15% per year → 5 points;
  - 5-10% per year → 10 points;
  - 0-5% per year → 15 points.

*Scoring summaries*

Each chapter needs to score a certain minimum number of points. If not, the difference between the score and the minimum is subtracted from the total score.

## 4. Lying and walking surfaces for cattle, pigs and poultry and their impact on health, behaviour and performance

B.J. Lensink<sup>1</sup>, E. Ofner-Schröck<sup>2</sup>, M. Ventorp<sup>3</sup>, P. Zappavigna<sup>4</sup>, J. Flaba<sup>5</sup>, H. Georg<sup>6</sup> and D. Bizeray-Filoché<sup>7</sup>

<sup>1</sup>Groupe ISA Lille, Equipe CASE, 48 boulevard Vauban, 59046 Lille cedex, France; <sup>2</sup>LFZ Raumberg-Gumpenstein, 8952 Irdning, Austria; <sup>3</sup>SLU – Swedish University of Agricultural Sciences, Biosystems and Technology, P.O. Box 86, 23053 Alnarp, Sweden; <sup>4</sup>University of Bologna, DIPROVAL Viale Fanin 46, 40127 Bologna, Italy; <sup>5</sup>Service Public de Wallonie, DGO3, Chaussée de Louvain, 14, 5000 Namur, Belgium; <sup>6</sup>VTI – Johann Heinrich von Thünen Institut, Institute of Organic Farming, Trenthorst 32, 23847 Westerau, Germany; <sup>7</sup>Institut Polytechnique LaSalle Beauvais, Equipe CASE, rue Pierre Waguet, 60002 Beauvais cedex, France; [joop.lensink@isa-lille.fr](mailto:joop.lensink@isa-lille.fr)

### Abstract

Animals spend during the day an important part of their time lying, walking or standing. In a natural environment often more or less elastic ground surfaces such as pasture or sand are found. However, farmed species spend often the major part of their life inside a building on floors with hard surfaces for walking and standing, or when the floor is also used for lying purposes a substrate such as straw or sand dust can be found on it. Regarding the animals' needs, floors should provide physical and thermal comfort when lying and should not lead to injury; allow standing up and walking without slipping or, on the contrary, too much friction; allow cleanliness of the animals in order to prevent transmission of infectious diseases, etc. However, next to these requirements floorings should also be easy to clean and facilitate manure handling and management; be sustainable with a minimum environmental impact; be cost efficient, etc. All these requirements are not easy to meet and therefore the physical properties of floors and the way they are managed by the stockperson can have significant effects on the thermal comfort of the animals, their health and injuries and consequently on their productivity.

**Keywords:** flooring, bedding, injuries, claw health

### 4.1 Introduction

Most farm species spend more than half of their time of the day lying down depending on several factors: age of the animal, its physiological status, general thermal conditions of the environment, group size and composition, comfort of the lying surface, general management (such as type of diet and its distribution), etc. At the same time animals engage in locomotor activities needed for most of their behaviours, such as feeding, drinking, social interactions or elimination. In a natural environment, animals perform both lying and locomotor behaviour on more or less soft, elastic ground surfaces such as pasture or sand. However, in buildings more hard surfaces are found or when the floor is also used for lying purposes a substrate such as straw or sand dust can be found on it. In certain cases, floors can contain openings to allow faeces and urine to pass to an underlying pit for storage (i.e. slatted floors).

Regarding the animals' needs, floors should provide physical and thermal comfort when lying and should not lead to injury; allow standing up and walking without slipping or, on the contrary, too much friction; allow cleanliness of the animals in order to prevent transmission of infectious diseases, etc. (CIGR, 1994; EFSA, 2005). When the same type of floor is used for both lying and locomotion, some of these needs can be contradictory especially in cattle and pigs: a soft, cushioning or even smooth surface is needed for comfortable lying behaviour, while a more hard and abrasive surface is needed for standing up and locomotion. However, next to these requirements floorings should also be: easy to clean and facilitate manure handling and management; be sustainable with a minimum environmental impact; be cost efficient, etc. (CIGR, 1994). In practice, it seems difficult to meet all these requirements at the same time. For example in pigs, slatted floor slurry disposal systems with few substrates require less labour and maintain the animals more clean compared to bedded systems, but lead to lying discomfort, more hock lesions and lameness (e.g. Lewis *et al.*, 2005; Mouttotou *et al.*, 1998).

Regarding floor properties for lying behaviour and locomotion in livestock buildings, five important factors are considered (for review: Von Wachenfelt, 2009): friction, abrasiveness, hardness, surface profile and thermal properties. Friction has an impact on traction and slips when animals are in movement which is particularly important in cattle and pigs. Abrasiveness influences the rate of claw wear, too little or too much can lead to deformation, dissymmetric growth or potential injury. Hardness determines the maximum stress that a tissue receives and is important specifically for claw health. Regarding lying behaviour, both abrasiveness and hardness can have an impact on for example superficial injuries such as abrasions and hock lesions in pigs and cattle (e.g. Weary and Tazkun, 2000). Soft surfaces may allow deformation of the surface which reduces contact pressure and mechanical stress of both the body and feet. Concerning surface profile, sharp edges can cause stress in underlying tissue leading to injury. Small surface-to-void irregularities can lead to the same effect. Finally, thermal properties of a floor in terms of temperature, conduction or isolation can affect lying and / or standing postures and physiology.

In this chapter we will discuss the different floor types that can be found for cattle, pigs and poultry. The different aspects of the floors and/or bedding or substrate used and their properties will be discussed regarding the requirements for the animals but also for other farm management purposes.

## **4.2 Lying and walking surfaces in cattle**

### **4.2.1 Lying surfaces in cattle**

Cattle spend a major time of their time lying down. Calves spend more than 75% of their time lying and resting during their first weeks (Le Neindre, 1993), while dairy cows can rest for 8 to 14 hours depending on the housing system, its quality and individual differences (e.g. Drissler *et al.*, 2005; Rushen *et al.*, 2007). Generally, increased resting times improve productivity. For example, the longer resting times cows have the more blood circulation in the udder will be observed and thus result in a higher milk production. Lying areas for cattle must provide ideally a comfortable, cushioning, clean and dry surface. However, for certain categories such as veal calves or fattening bulls, animals can be kept for lying/resting on wooden (or sometimes concrete) slatted floors.

#### 4. Lying and walking surfaces for cattle, pigs and poultry

Two types of bedding can be distinguished in cattle housing: (1) loose material such as straw, sawdust, wood chips or sand either as a deep layer (200 mm) placed directly on the base of the stall or a thin layer over a mat or mattress; or (2) materials fixed to the base of the cubicle such as rubber mats or various synthetic mattresses. The different properties of a range of materials will be discussed and when available consequences on animal comfort, health and productivity indicated. A summary of different bedding materials and their properties is found in Table 4.1.

##### Slatted floors

Slatted floors as a lying surface exist in special housing systems for veal calves, beef cattle or young replacement cattle. Slatted floors can be covered partly by using rubber mats with slots that fit in concrete slat elements. Compared to other housing systems using cubicles, fully slatted floors with rubber coated lying surface are mostly associated with dirtier animals (Lowe *et al.*, 2001). Housing of replacement heifers on slatted floors without cubicles may lead to a lower acceptance

Table 4.1. Evaluation of different materials used as bedding for cattle.

	Housing systems	
	Bedded pack/sloped floor	Cubicles and tie stall
Straw	+++	+++ : if the daily bringing is sufficient
Sawdust	++ : sawdust alone	+ to ++ : sawdust alone
	+++ : sawdust with straw + to ++ : sawdust from resinous wood	+++ : sawdust with straw (dairy cow ++) +++ : sawdust with wood shaving
Wood shaving	+++ : a layer of 20 cm to drain the bedded pack	+++ : with sawdust or straw
Wood chips	Particle size can be a problem, prickles and too big particles can harm animals	
Bark	- to + : tannin, limited absorption of humidity	- to +
Maize straw	- to + : too humid, must be grinded	
Rapeseed straw	Limited absorption of urine; to use as under layer	
Miscanthus (Elephant grass)	Absorption of humidity higher than straw	
Fernery	Used regularly in the past, not very comfortable, limited absorption of urine	
Rice straw	+	++
	Less absorbent than other cereals, good product as substitute	
Paper or cardboard	To use with straw and/or sawdust; ink could be a problem	
Compost	+++ : as compost yard; the maintenance is of great importance	A layer of 20 cm is required Comfortable Hygiene could be a problem
	Sand	Not suitable



rate of cubicles, when heifers are introduced in the dairy herd (Hultgren and Bergsten, 2001). A study on lying surfaces for finishing bulls demonstrated, that there is no difference between bulls kept on fully slatted floors with soft rubber mats as lying surface compared to straw based cubicles regarding leg lesions and swellings (Schulze-Westerath *et al.*, 2007). Keeping fattening bulls on fully slatted concrete floors without soft lying area resulted in higher leg lesion scores and swellings in the same study. Rubber coating as lying surface together with an adequate stocking density is the most favourable design option from welfare point of view, when designing houses for fattening bulls.

### *Straw*

Straw as a bedding material can be used in different types of loose housing systems (straw yards and sloped floor systems, cubicle systems) as well as in tied housing. Often straw from wheat or barley is used, but also rice or rapeseed straw can be found depending on the availability.

In straw yard systems, straw is spread over the whole resting area. To keep animals clean 1.0 to 1.2 kg/day/m<sup>2</sup> is required (CIGR, 1994). It is important to use chopped straw of 200 to 300 mm in length as long straw gives a wet litter with more dirty animals. Fresh straw must be added daily and it must be dry and free of mould. The surface temperature of the bedded area is influenced by the quantity of straw spread every day. Using too much straw (>1.2 kg/day/m<sup>2</sup>) increases the surface temperature of the bedding area and increases the development of micro-organisms in the litter having a potential effect on udder health (somatic cell count and clinical mastitis) (Hétreau and Menard, 2005). However, below 0.7 kg/day/m<sup>2</sup>, or when there is overcrowding animals are too dirty and the risk for mastitis increases. The demand for straw will vary depending on the layout, management, required cleanliness of the cows and climate.

In general for cubicle systems but also tied housing, the use of bedding alone, on a concrete base without kerb, is unlikely to give a comfortable, resilient bed, unless large amounts of material are used. In the case of straw, a minimum of around 2.5 to 3 kg per cow per day will be required. Cubicles should be ideally inspected twice-daily and wet bedding and manure should be removed. Clean, dry bedding should be added at least twice a week or more frequently if possible in order to assure optimal comfort and hygiene for the animals. If the cleanliness of cubicles is neglected and they become excessively wet or soiled with manure, then infectious bacteria populations may exceed critical values. This will give rise to an increase in the rate of udder infection.

The major problem of straw is its availability in certain countries and its cost. Alternative bedding systems using less straw have been developed and can be useful in practice. For example, straw-manure-mattresses can be used in cubicle or tie-house systems. As a sub-floor a simple concrete floor is sufficient. Straw-manure-mattresses consist of straw-rich manure from the own housing system which is introduced directly onto the concrete floor between bricket board and kerb and tamped well (Jakob and Oertli, 1992). Its layer should be at least 15 cm thick allowing a comfortable surface to the animals with only 0.3 kg to 1 kg straw per animal per day. However, by scratching and kicking of the animals holes can arise in the mattress, which are best to fill with manure from the own farm. This system is considered better for the animals than most of the other beddings as it prevent abrasions and inflammation in the joints (ÖKL, 2010). Regarding to

#### 4. Lying and walking surfaces for cattle, pigs and poultry

bacterial load (mastitis) the straw-manure-mattress can be classified as equivalent to, for example, different rubber mats (Reithmeier, 2002).

##### *Compost and manure solids*

Compost is an inexpensive alternative to straw and can be used in loose housing systems with a free lying area (compost barns) as well as in cubicles. Compost barns have generally a concrete feed alley and a bedded pack resting area. Fresh bedding consisting of dry fine wood shavings is added (0.4 to 1.3 m<sup>3</sup> per animal) every 2 to 7 weeks. Stirring two times a day aerates and mixes manure and urine on the surface into the pack to provide a fresh surface for animals to lie down on. The pack can provide manure storage for approximately 6 months until the pack reaches a depth of 50 to 60 cm. The lying comfort for the cow is excellent as no abrasions or inflammations of joints are found (Janni *et al.*, 2007). In cubicles mature compost from a compost heap can also be used. Mature compost has a fine, crumbly texture. The bedding height in the cubicles is 8 to 20 cm and 1 to 2.7 kg per cow per day fresh litter can be introduced leading to equivalent comfort as straw-manure-mattresses (Schrade and Zähler, 2008).

Solids from manure can also be used as bedding for cattle housed in cubicles. For the separation of raw slurry into solid components (solids) and a liquid phase (thin slurry) a screw press separator is used. The bedding material is placed into the cubicles every 1 to 3 weeks with a bedding height of 8 to 25 cm. The lying surface smells peaty, is compact and malleable. A disadvantage of this system is the rather high cost (depending on the type of the separator and the herd size). Advantages include the reduction of slurry volume, the more precise application of slurry on the field and the slurry management without an agitator (Schrade and Zähler, 2008).

##### *Sawdust, wood chips, bark and shavings*

Sawdust can provide a comfortable lying surface for cattle in cubicles, as long as it contains no sharp ended particles and depending on the thickness of the layer (a minimum of 10-15 cm). Besides the comfortable bedding properties, sawdust has the disadvantage to have a higher bacterial load and therefore a higher incidence for environmental based mastitis or other negative bacterial effects regarding udder health (Zdanowicz *et al.*, 2004). When using sawdust together with liquid manure and slatted floors, special attention has to be paid to avoid accumulation of sawdust in the slurry pit in order to keep the slurry system working.

Rarely used in cubicles, wood chips and/or bark are more often used in open wintering pens for cattle or exercise yards to achieve a drainage effect and keep the lying surface dryer. Pine wood shavings may reduce bacterial loads, due to the resins naturally present. If bedding in cubicles should be considered because of local availability, special regard should be taken on the quality of the material, because sharp ended particles may lead to injuries on legs or udder of dairy cows.

##### *Sand*

Sand as bedding material (Figure 4.1) is mainly used in Northern America or other countries where flushing of dunging alleys is used for manure removal. Due to the positive properties



Figure 4.1. An example of sand bedding in a cubicle.

of sand when used as bedding material (comfort, low bacterial counts, availability) its use becomes also more widespread in Europe. Special attention has to be paid to the manure removal technique as scrapers may erode rapidly when sand loaded manure is removed. If sand is recycled as bedding material, a higher proportion of organic matter has to be considered and may lead to higher bacterial loads (Justice-Allen *et al.*, 2010), but even clean sand, if not managed well, may have the same bacterial load (Kristula *et al.*, 2008). To maintain the comfort of sand bedded cubicles, it is important to maintain a base height of sand (as high as the curb). The use of old car tires as a base can keep sand (and comfort) within the cubicles, commercial solutions using wafer-like rubber mats are available as well. Lying (and therefore resting) time may decline up to 2.3 hours for poor maintained (thin layer) sand cubicles compared to a full sand layer (Drissler *et al.*, 2005). When sand beddings in cubicles are well managed they can lead to longer resting times, cleaner cows and less hock lesions compared to all other beddings or mattresses used in cubicles (Lombard *et al.*, 2010).

#### *Use of mats or mattresses*

An important number of mats and mattresses made of different material (rubber, geotextile...) and that differ in thickness, softness and cover material (external layer) are available on the market. It is impossible to evaluate correctly all of these products used mainly in cubicle systems. However, they should all meet the following general requirements: be soft in order to improve lying comfort and to prevent injuries on the front knees when animals lay down; be durable 'elastic' in the way that the softness properties might disappear in time; provide a minimal level of grip when an animal stands up; be easy to clean (CIGR, 1994). Although rubber mats are more comfortable for the animals than bare concrete with a thin layer of substrate, it can be stated that

## 4. Lying and walking surfaces for cattle, pigs and poultry

care should be taken with a certain number of products. Rubber mats can be too thin and too hard leading to potential injuries on the front legs when animals are kneeling down for lying (Rushen *et al.*, 2007). Furthermore, when too thin (less than 3-4 cm) it can be stated that the lying comfort is impaired and rather (geotextile) mattresses or comfort mats should be encouraged (Wechsler *et al.*, 2000). For dairy cows, when available, bedding material such as sawdust could be used on top of the mats or mattresses in order to absorb moisture and keep the lying area more clean (Weary and Taszkun, 2000).

### 4.2.2 Walking surfaces for cattle

In cattle, especially in loose housing systems, it is of critical importance that the animals can move without any problems and discomfort on floors between the lying area, feeding and drinking places, milking area, etc. Next to locomotion, cattle also have to perform other behaviours on the same surface such as social and oestrus behaviour or cleaning. Since the claws have a close physical contact and interaction with surfaces of walking areas and passageways, the significance of flooring for healthy claws makes sense. Although the different claw disorders have a multifactorial etiology (nutrition, genetics, management, etc.), the different floor properties and the way floors are managed are probably the most important parameters influencing claw health and lameness, and indirectly milk yield and growth.

#### *Clean and dry flooring*

Claw exposure to moist or wet walkway surfaces results in absorption and softening of claws, which enhances the risk for lameness (Borderas *et al.*, 2004), while poor floor hygiene may lead to infectious claw lesions (Fjeldaas *et al.*, 2011). Additionally, dirty passageways in cubicle houses, especially in combination with low cubicle kerb height, can lead to poor cubicle hygiene, dirty udders, lower milk quality and increased risk for mastitis (Magnusson *et al.*, 2008). In most cattle production systems, floors are either solid (concrete, asphalt, etc.) or slatted (mostly concrete, sometimes wood). In the case of solid floors, frequent removal of manure and satisfactory floor fluid drainage is essential in order to maintain clean and dry floors and claws. In the case of slatted floors, manure and urine fall down in a pit beneath. Slatted floors perform therefore well concerning the dryness of the walking surface, although regular (mechanical) scraping of the manure should be advised as it reduces claw disorders compared to non-scraping (Somers *et al.*, 2005). Care should be taken with the type and quality of slatted concrete floors. Badly designed slatted concrete floors (i.e. slot and slat dimensions and shapes) can be traumatic, because pressures under contact area are not equally distributed over the claw surface and the hit of the hoof against the edge of the slot can be very hard. At the forelimbs and at the hind limbs, respectively, the medial claws and the lateral claws are more often subjected to maximum pressures exerted on a foot while standing still. The regions in which these maximum pressures occur are known to be relatively susceptible to injuries (Telezhenko *et al.*, 2008).

#### *Physical properties of the floor: hardness*

In an optimal claw environment rates of claw horn growth and wear are more or less equal (Vermunt and Greenough, 1996). Abrasive floor surfaces can lead to loss of concavity of claw

soles, which certainly means increased claw-floor contact area but reduce the weight-bearing role of the strongest part of the claw capsule, the claw wall (Telezhenko *et al.*, 2008). Hard floor surfaces such as concrete and mastic asphalt can cause discomfort and traumas and lead to abnormal hoof growth, which may predispose to sole haemorrhages and ulcers (Lischer, 2000). Cattle prefer to walk and stand on softer flooring (Tucker *et al.*, 2006). Several studies have shown a positive influence of soft floor surface on animal conditions. For example, cows in straw yards have substantial fewer claw disorders than cows exposed to concrete flooring (Somers *et al.*, 2003, 2005). The recent use of elastic (rubber) surfaces as a cover on solid concrete or slatted floors leads to contrasting results either increasing, decreasing or having no incidence on claw disorders in the herd, although overall lameness is decreased compared to concrete floors (Hultgren *et al.*, 2009; Kremer *et al.*, 2007). Other effects of soft coverings compared with hard concrete flooring are greater animal activity (Kremer *et al.*, 2007) such as improved oestrus (mounting) and hygiene behaviour (caudal licking) (Platz *et al.*, 2008), total time spent eating (Tucker *et al.*, 2006), improved locomotion (e.g. Rushen and de Passillé, 2006). However, soft floor surface in walkways in cubicle houses can increase cattle lying down in the passageways, probably because of inadequate cubicle design and flooring (Platz *et al.*, 2008; Tucker *et al.*, 2006).

#### *Physical properties of the floor: slip resistance and abrasiveness*

Slippery floor surfaces can lead to cattle injuries because of splitting legs, falling down, claws' traumatic smashes or claws getting caught or jammed in contact with floor details, as well as disturbed locomotion (Telezhenko and Bergsten, 2005). The slip resistance can be measured by the friction between claw and floor surface, the greater friction coefficient the greater the slip resistance. The required coefficient of friction (i.e. providing against slipping) for moving cows is dependent on the cow behaviour; i.e. if the animal is walking straight ahead, turning, fleeing (accelerating) or stopping (decelerating), etc., as well as stance phase (i.e. from claws hits the footing to push-off). The maximum required coefficient of friction (static), mostly required at the hitting and push-off stance phase, ranges from 0.3 to 0.85 for various behaviours (Van der Tol *et al.*, 2005). It is possible to obtain a coefficient of friction up to 0.85. However, such an important coefficient of friction results in floors (such as concrete or mastic asphalt) that are too abrasive with a risk of claws been worn out. Normally, dry and clean concrete floors have a coefficient of friction of about 0.40 or less (Liberati and Zappavigna, 2010). Webb and Nilsson (1983) reported that below the critical value of 0.4 the risk of slip increases exponentially. Additionally, the real slip resistance will be dependent on several factors such as slurry coating on the floor (Telezhenko *et al.*, 2005), the measure device and method (Liberati and Zappavigna, 2010) and wearing of the floor material caused over time by grinding and polishing action of mechanical cleaning equipment and animal movements. Normally, concrete floors do not provide enough friction to allow natural locomotor behaviour (Van der Tol *et al.*, 2005). Considering that the slurry coating reduces the friction effect of a clean and dry floor the optimum coefficient of friction for concrete floors can be indicated between 0.4 and 0.5 (Phillips and Morris, 2001).

Sometimes, patterns of grooves in concrete floors are made in order to obtain better grip for the claws. However, grooves *per se* do not change cows' locomotion, provided that no change occurs with the surface between the grooves (Telezhenko *et al.*, 2005). It is possible that slipping claws can catch a groove stopping to continue to slip, but this is not substantiated. Slatted floors



#### 4. Lying and walking surfaces for cattle, pigs and poultry

can have a different effect on slipperiness: be very resistant when the movement direction is orthogonal to the slats (due to the effect of the slot edge) or be very slippery when the direction is along the slat. From the point of view of the mechanical stress of the bovine claw, a large contact area between claw and floor, as seen in the solid surface floor, is preferable. When use of slatted floors is unavoidable, direction of the slats should run perpendicular to the direction of the walkway to prevent even more mechanical impact in certain footing situations.

Mastic asphalt used as a concrete floor coating can be, according to some authors, a valid alternative to simple concrete (except for hot climate areas). However, excessive wear of the claw can be found (Telezhenko *et al.*, 2009) and bad lasting of the material because of its plasticity. A recent solution consists of covering concrete floors with a coat of epoxy resin with mineral aggregates embedded in. The increase in terms of coefficient of friction can be very great and depends on the size of aggregates. However the abrasion rate increases as well and can determine excessive wear (Phillips and Morris, 2001).

Again, soft floor as rubber (Figure 4.2) can partly fulfil the demand of slip resistance, depending on the surface characteristic and resilience, without risking great abrasiveness (Telezhenko *et al.*, 2009). However, pure rubber mats can reduce the wear of claws to that extent that more



Figure 4.2. Rubber flooring in passage way for dairy cattle.

frequent trimming is needed than with more abrasive floor surface. Alternatively, enhancing the abrasiveness of rubber floors, or combining rubber floor with abrasive surfaces in cattle houses' walkway lay-outs should be imagined. Until now, these technical alternatives are not fully studied.

### **4.3. Lying and walking surfaces for pigs**

For pigs kept indoors, standing, lying in various positions, walking, exploratory behaviour, social interactions, dunging, urination, etc., are often performed in the same area with only one or a maximum two type of flooring surfaces. Pigs use separate areas for lying and for urination and dunging except when the space allowance is insufficient or when stressed by heat or disease (for review: EFSA, 2005). Three categories of floorings can be distinguished in pig production based majorly on the way manure is handled: (1) slatted floors; (2) scraped (solid) floors; (3) deep litter systems. When a slatted floor is used often no or only a limited quantity of bedding is used. For pigs, the entire pen might be slatted but in certain cases a solid floored lying area combined with a slatted dunging area can be found. On scraped floors, distinct lying and dunging areas are found. Often, no or only limited bedding material is used and the manure is scraped manually or mechanically at regular intervals. Regarding deep litter systems, the total living area of the pigs is covered with some kind of bedding (straw, woodchips, etc.).

For floorings in pig production, in certain parts of the world, legislation has been introduced in order to establish minimum standards for different categories of animals. For example in the European Union, the Council Directive 2008/120/EC has laid down minimum standards for the protection of pigs indicating minimal space allowances, flooring design and need for bedding substrates. For this paragraph, these requirements will be discussed for 2 categories of pigs: farrowing sows and their piglets in the farrowing pen, and rearing (fattening) pigs. Other categories such as pregnant (gestating) sows and gilts, or boars will not be discussed in detail as the floorings are similar to those used for farrowing or rearing pens.

#### **4.3.1 Farrowing pens**

Floors in farrowing pens or crates (Figure 4.3) have to respect the needs of the sow but also her piglets. For farrowing, most sows are kept in individual crates restricting considerably their freedom of movement in order to prevent piglet crushing. During the first week of lactation sows spend more than 80% of their time during the day and more than 95% at night lying down; this time spent lying down decreases in favour of standing after the first week of lactation (De Passillé and Robert, 1989). Lactating sows spend long periods in lateral recumbence (Zurbrigg, 2006), which is considered to be more comfortable for sows, because when lying sternally, only 10 to 20% of the animals' total body surface is in contact with the floor (Elmore *et al.*, 2010). The floor properties are therefore extremely important in terms of lying comfort. For example, metal slatted flooring is a risk factor for decubitus, ulcers and pressure sores on sows' shoulders compared to sows housed on solid concrete (Zurbrigg, 2006). Solid floors lead also to lower frequencies of teat damage in lactating sows compared to perforated (slatted) floors especially if the latter ones present sharp edges. When shoulder ulcers appear, providing a rubber mat helps to heal the wounds rapidly (Zurbrigg, 2006). Although there is a lack of experimental studies on the effects of floor quality on sow health in farrowing pens, it can be stated that, when sows are kept in their

#### 4. Lying and walking surfaces for cattle, pigs and poultry



Figure 4.3. A typical farrowing crate for sows with a solid metal floor for the sow and plastic slatted floor for piglets.

thermo-neutral zone, preferably solid floors (concrete, metal, etc.) should be used for the lying comfort of the sow. However, the sow requires an abrasive surface in order to prevent slipping when standing up or lying down. At the same time, the surface behind the sow needs to have slats with a reasonable, relatively large void area (maximum of 20 mm), that are as near as self-cleaning as possible in terms of manure disposal.

Piglets have different thermal and physical requirements than sows. During the first days of life, piglets spend most of their time either lying in the nest (under a heat lamp or on a heat pad), or suckling their mother. For the piglet area often either a partially or completely slatted floor is used. The width of the gaps of the slatted floor and the type of material that it is made of are important for the piglets' leg and foot health. As a matter of fact, if the gaps are too wide, piglets' feet might pass through the perforation in the floor which can lead to digit, coronet and footpad lesions. For this reason, EU legislation (2008/120/EU) has set the maximum width of openings in slatted floors at 11 mm for piglets. Regarding the material, slatted floors made of plastic-coated expanded metal should be preferred to slatted steel as plastic reduces the injurious chaffing and rubbing associated with freeing the trapped foot (Lewis *et al.*, 2005). During suckling, new-born piglets are close to their mother and are therefore often on an abrasive surface. The piglets may develop sole and carpus lesions and different skin abrasions during their first three days of life especially on the front legs as a result of contact with the floor and they may be amplified by paddling at suckling (Zoric *et al.*, 2009). Rubber mats in the sow area considerably reduce carpus lesions of the piglets (Courboulay *et al.*, 2000), although the quality and type of rubber mats might play a role as well. Generally, the scab over the lesions will heal with time and piglets recover within 4-5 weeks. However, skin abrasions can be entry points for bacteria such as *Streptococcus dysgalactiae*



(subsp. *equisimilis*), leading to infections which might transform in potential lameness caused by arthritis (Zoric *et al.*, 2009). When farrowing pens are completely bedded (deep straw bedding) there is a lower prevalence of skin abrasions or sole erosions compared to slatted floors. However, adding some straw or other litter to the farrowing pen equipped with solid floors or slats is not always effective in preventing abrasions or lesions, because the piglets may remove the litter with their physical activity (Zoric *et al.*, 2009). When slatted floors are used for the sows' lying surface, care should be taken to the type of material it is made of. As a matter of fact, piglets prefer plastic-coated expanded metal over other types of slatted floors (Pouteaux *et al.*, 1983). Hence, when the entire farrowing crate floor is covered with this material, this might increase the time spend by piglets outside the heat pad near their mother and therefore potential increase piglet crushing (Lewis *et al.*, 2005).

#### **4.3.2 Rearing pigs**

For rearing pigs, including fattening and finishing pigs, all behaviours (such as lying, locomotion, dunging, etc.) are performed in the same area/pen, i.e. generally no distinctive areas are found for the different activities. The floor type in rearing pigs has an important impact on activity levels, lying and locomotion comfort, cleanliness and injuries. General activity patterns and levels of pigs differ according to the floor type and / or the presence of bedding. Rearing pigs on bedded floors show higher levels of activity compared to (partly or fully) slatted floor types (Lyons *et al.*, 1995). However, this is not necessary attributable to the properties of the floor but rather to the increased exploratory behaviour due to the presence of a substrate. When comparing fully-slatted floor to solid floors, there seems to be a tendency for a slightly higher activity of the pigs on solid floors (Lyons *et al.*, 1995), while fully-slatted floors seem not to differ from partly-slatted floors on this point. Although general activity levels might differ between floor types, generally no differences are found in growth results.

Rearing pigs can walk, when kept on slatted floors and at standard densities, between 250 and 600 meters per day when in a pen of 6 or 12. This distance is higher at the beginning of fattening than towards the end and when kept in bigger groups (Brendle and Hoy, 2011). As this distance walked per day can be considered as high, it can be easily imagined that the properties of the floor type influence leg and foot health. As a matter of fact, in a survey on 21 units including an observation of more than 4000 finishing pigs, the prevalence of foot lesions ranged from 79 to 100% on different units (Mouttotou *et al.*, 1999). In this study, whatever floor type induced different lesions. For example, bedded floors (either sparse or deep straw) led to a lower prevalence of sole and heel erosions, but a higher prevalence of toe erosions compared to solid concrete floors (Mouttotou *et al.*, 1999; Scott *et al.*, 2004). Often exact technical details on floor surface properties are lacking. Factors such as high abrasiveness of the surface can lead to more frequent and severe lesions than a smooth surface (Wright *et al.*, 1972). However, concrete and other materials will change their properties in time with wear and cleanliness. This means that floors should be regularly inspected on their roughness/slipperiness and risk of cracks.

Rearing pigs prefer to lie on a solid floor and the presence of bedding makes the solid floor more attractive for exploration compared to slatted floors (EFSA, 2005). However, cleanliness of pigs is generally lower on solid floors compared to partly or fully-slatted floors (EFSA, 2005). The

#### 4. Lying and walking surfaces for cattle, pigs and poultry

cleanliness is an important aspect related to health. For example, slatted floors compared to solid floors in the dung area lead to cleaner pigs and better general pen hygiene. Especially for weaning piglets, this might reduce the risk of *E. coli* spread and therefore diarrhoea and mortality (Rantzer and Svendsen, 2001). Next to the cleanliness of the pigs, the rate of removal of faeces and urine such as in slatted floors or on scraped floors seems to reduce the risk of infectious diseases in fattening pigs in general (EFSA, 2005). In rearing pigs, when bedding cannot be provided in large quantities, neither complete solid floors nor fully-slatted floors seem to be optimal regarding lying behaviour and cleanliness, and rather a partly-slatted floor should be advised. However, the percentage of solid vs. slatted floor in this case is questionable. Few studies are available on the ideal percentage of solid vs. slatted when partly-slatted, although some countries have stated requirements in their legislation (e.g. the Netherlands: 40% of solid floor; Denmark: 33%). Providing bedding to pigs does not always lead to cleaner animals as this depends on the season (Scott *et al.*, 2004). However, bedding as such can be source of different health problems. For example, *Mycobacteria* can be brought in by sawdust and woodchips or straw might vehicle more easily infectious diseases leading finally to, for example, more respiratory disorders or PMWS (Post weaning Multisystemic Wasting Syndrome) symptoms (Scott *et al.*, 2004).

The major injury related to lying behaviour in rearing pigs is (adventitious) bursitis of the hock. In a survey on 21 farms in the United Kingdom, the overall prevalence of bursitis was 51.0% and ranged from 10.1 to 84.0% in the different units. There was a significant trend in the prevalence of bursitis with floor type; pigs kept on solid concrete floors with deep straw (>10 cm) had the lowest risk of having bursitis, and the prevalence increased successively when the floors were solid concrete with sparse straw (<10 cm), partly-slatted and fully-slatted (Moultotou *et al.*, 1998).

In conclusion, partly-slatted floors should be probably preferred to fully-slatted floors in rearing pigs as this leads to less bursitis, claw injuries and lameness. However, pen hygiene and disease aspects are more frequent and no hard statement can be made today on what should be the ideal percentage of solid floor for rearing pigs, although some countries have stated requirements in their legislation. Bedding has a positive influence on the pigs' general activity, lying comfort and injuries such as bursitis. However, different foot lesions are present at high levels on whatever floor type and seem difficult to resolve completely.

#### 4.4. Lying and walking surfaces in poultry

Except for laying hens kept in caged systems, most poultry are kept on surfaces with litter. Litter substrates are generally composed of straw, wood shavings, peat or residues from plants used for textile (e.g. linen or flax) or from the paper industry. The litter is used on the entire floor area, however in certain cases an elevated slatted floor can be found in certain areas of the barn depending on the production type (e.g. laying hens). Litter management is one of the most important factors that influence the welfare of specifically broiler chickens and turkeys (European Commission, 2000). Firstly, poultry spend the major part of their time lying on the litter. Prolonged contact with litter of poor quality (especially if too wet) may lead to contact pododermatitis, hock and breast blisters. These ulcerations or blisters may lead to a high level of suffering, can be a possible entry for bacteria, preventing animals to walk, and finally lead to decreased feed ingestion and reduced growth rate. Secondly, litter quality influences also several

environmental parameters (dust level, air moisture, ammonia concentration, etc.), which may affect building atmosphere and increase respiratory diseases.

Table 4.2 resumes the effects of litter quality parameters and other management practices impacting litter quality on meat poultry welfare (Berg, 1998; Bruce *et al.*, 1990; Ekstrand *et al.*, 1997, 1998; Martrenchar *et al.*, 2002; Shanawany, 1992; Waldensted, 2006). High stocking density is known to decrease litter quality, but this effect can be compensated by adequate ventilation. However, high density can lead to more heterogeneity in space utilisation, which can lead to some areas with very bad litter quality which in turn increases dermatitis in chickens (Arnould and Faure, 2004).

Only limited scientific information is available on the effect of soil type on laying hens welfare. Most cage floors are made of rectangular welded wire mesh coated to increase durability and to give them a smooth finish. In non-cage systems, the litter area is usually the floor surface (concrete, etc.) covered with litter. Presence of litter or substrate in non-cage systems and in new furnished cages allows hens to express more comfort behaviours, like dust bathing.

#### 4.5. Conclusion

For both cattle and pigs it can be considered that the floor properties, when used for walking and standing, have globally the same impact on claw and leg lesions. Floors that are too soft lead to overgrown heels and/or claws. Slipperiness of floors leads to injuries especially on joints and accessory digits in pigs, while in adult cattle even more serious problems may arise (e.g. bone fracture, etc.). Excess of manure and urine due to insufficient cleaning of the surfaces on which

*Table 4.2. Impact of different environmental factors related to litter quality on characteristics improving or decreasing meat poultry welfare.*

Environmental factor	Characteristics improving animal welfare	Characteristics decreasing animal welfare
Litter quality		
water holding capacity	high (wood shavings, etc.)	low (straw, etc.)
type of floor	concrete	mud
litter depth	thin (<5 cm)	thick
Other management practices impacting welfare <i>via</i> litter quality		
feed concentration in Na <sup>+</sup> and K <sup>+</sup>	normal	excess (then over drinking)
faecal viscosity ( <i>via</i> feed composition)	low	high (then sticky litter)
drinker design (water spillage)	low	high
age of animal removal	less	great
stocking density	low	high (but compensation if good ventilation)
relative humidity	low (summer...)	high (winter...)
ventilation equipment	good	poor

#### 4. Lying and walking surfaces for cattle, pigs and poultry

animals stand and walk leads to softened tissues (sole, claw) which in turn might cause specific claw infections and finally lameness. Poorly designed slatted floors or level differences can lead to small injuries or claw cracks.

The use of rubber in both cattle and pig production might prevent number of injuries or claw problems but more objective data are needed on certain aspects. The use of rubber mats or mattresses for lying purposes (in cubicles) in cattle is widespread. However, many products are available on the market which differ widely in thickness, softness and roughness, and certain of these product should not be advised especially those which are too hard and that have insufficient thickness (below 3-4 cm). When rubber is used in walking areas for cattle, the expression of oestrus and social behaviour can be improved and lameness can be reduced. Again, several products are available to the farmers which differ in quality and technical aspects. In any case, proper management of these floors (frequent scraping) and the herd (claw trimming) is needed. The use of rubber mats in pig production for both lying and walking purposes can be an option to improve lying comfort and to limit leg and claw injuries, but more scientific data are needed before wider use in large scale pig operations.

Bedding is profitable for all species regarding lying comfort, but in species such as pigs or poultry care should be taken with possible bacterial development which can be detrimental to their health. The provision of bedding leads to different manure management, however bedding materials such as straw and wood shavings may become scarce in the future related to their other uses and to difficulty of straw supply in certain regions or countries.

#### References

- Arnould, C. and Faure, J.M., 2004. Use of pen space and activity of broiler chickens reared at two different densities. *Applied Animal Behaviour Science* 87: 155-170.
- Berg, C.C., 1998. Foot-pad dermatitis in broilers and turkeys – prevalence, risk factors and prevention. *Acta Universitatis Agriculturae Sueciae, Veterinaria* 36. Ph.D. Thesis. Swedish University of Agricultural Sciences, Uppsala, Sweden.
- Borderas, T.F., Pawluczuk, B., de Passille, A.M. and Rushen, J., 2004. Claw hardness of dairy cows: Relationship to water content and claw lesions. *Journal of Dairy Science* 87: 2085-2093.
- Brendle, J. and Hoy, S., 2011. Investigation of distances covered by fattening pigs measured with Video Motion Tracker®. *Applied Animal Behaviour Science* 132: 27-32.
- Bruce, D.W., McIlroy, S.G. and Goodall, E.A., 1990. Epidemiology of a contact dermatitis of broilers. *Avian Pathology*, 19: 523-537.
- CIGR. 1994. The design of dairy cow housing. Report of the CIGR working group No. 14. ADAS Bridgetts Dairy Research Centre, Farm Building Research Team, Reading, UK.
- Courboulay, V., Le Roux, A., Collin, F., Dutertre, C. and Rousseau, P., 2000. Incidence du type de sol en maternité sur le confort de la truie et des porcelets. *Journées de la Recherche Porcine* 32: 115-122.
- De Passillé, A.M.B. and Robert, S., 1989. Behavior of lactating sows: influence of stage of lactation and husbandry practices at weaning. *Applied Animal Behaviour Science* 23: 315-329.
- Drissler, M., Gaworski, M., Tucker, C.B. and Weary, D.M., 2005. Freestall maintenance: effects on lying behavior of dairy cattle. *Journal of Dairy Science* 88: 2381-2387.

- EFSA, 2005. The welfare of weaners and rearing pigs: effects of different space allowances and floor types. *EFSA Journal* 268: 1-19.
- Ekstrand, C., Algers, B. and Svedberg, J., 1997. Rearing conditions and foot-pad dermatitis in Swedish broiler chickens. *Preventive Veterinary Medicine* 31: 167-174.
- Ekstrand, C., Carpenter, T.E., Andersson, I. and Algers, B., 1998. Prevalence and prevention of footpad dermatitis in broilers in Sweden. *British Poultry Science* 39: 318-324.
- Elmore, M.R.P., Garner, J.P., Johnson, A.K., Richert, B.T. and Pajor, E.A., 2010. A flooring comparison: the impact of rubber mats on the health, behaviour, and welfare of group-housed sows at breeding. *Applied Animal Behaviour Science* 123: 7-15.
- European Commission, 2000. The welfare of chickens kept for meat production (broilers). Report of the Scientific Committee on Animal Health and Animal Welfare, adopted 21 March 2000. 149 p.
- Fjeldaas, T. Sogstad, A.M. and Osterås O., 2011. Locomotion and claw disorders in Norwegian dairy cows housed in free-stalls with slatted concrete, solid concrete or solid rubber flooring in the alleys. *Journal of Dairy Science* 94: 1243-1255.
- Hétreau, T. and Menard, J.L., 2005. Effect of compacting on the variation of the temperature of the straw bedding. *Proceedings 12<sup>th</sup> Congress 3R – recontres des recherches sur les ruminants*, Paris, France, 252pp.
- Hultgren, J. and Bergsten, C., 2001. Effects of a rubber-slatted flooring system on cleanliness and foot health in tied dairy cows. *Preventive Veterinary Medicine* 52: 75-89.
- Hultgren, J., Telezhenko, E., Ventorp, M. and Bergsten C., 2009. Walkway floor design, feed stalls, claw lesions and locomotion in Swedish cubicle-housed dairy cattle. In: *Sustainable animal production. The challenges and potential developments for professional farming*. Wageningen Academic Publishers, Wageningen, the Netherlands, pp. 121-133.
- Jakob, P. and Oertli, B., 1992. Strohmattmatratzen in den Liegeboxen. *FAT-Berichte*, Nr. 416, Tänikon, Switzerland.
- Janni, K.A., Endres, M.I., Reneau, J.K. and Schoper, W.W., 2007. Compost dairy barn layout and management recommendations. *Applied Engineering in Agriculture* 23: 97-102.
- Justice-Allen, A., Trujillo, J., Corbett, R., Haring, R., Goodell, G. and Wilson, D., 2010. Survival and replication of *Mycoplasma* species in recycled bedding sand and association with mastitis on dairy farms in Utah. *Journal of Dairy Science* 93: 192-202.
- Kremer, P.V., Nueske, S., Scholz, A.M. and Foerster, M., 2007. Comparison of claw health and milk yield in dairy cows on elastic or concrete flooring. *Journal of Dairy Science* 90: 4603-4611.
- Kristula, M.A., Dou, Z., Toth, J.D., Smith, B.I., Harvey, N. and Sabo, M., 2008. Evaluation of free-stall mattress bedding treatments to reduce mastitis bacterial growth. *Journal of Dairy Science* 91: 1885-1892.
- Le Neindre, P., 1993. Evaluation housing systems for veal calves. *Journal of Animal Science* 71: 1345-1354.
- Lewis, E., Boyle, L.A., O'Doherty, J.V., Brophy, P. and Lynch, P.B., 2005. The effect of floor type in farrowing crates on piglet welfare. *Irish Journal of Agricultural and Food Research* 44: 69-81.
- Liberati, P. and Zappavigna, P., 2010. An instrument for measuring the skid resistance of floors in livestock housing. In: *Proceedings of the XVIIth World Congress of the International Commission of Agricultural and Biosystems Engineering (CIGR)*. June 13-17, 2010.
- Lischer, C.J., 2000. *Sohlengeschwüre beim Rind – Pathogenese und Heilungsverlauf*. Dissertation. Veterinär-Chirurgische Klinik Universität Zürich. Zürich, Switzerland.
- Lombard, J.E., Tucker, C.B., Von Keyserlingk, M.A.G., Koprak, C.A. and Weary, D.M., 2010. Associations between cow hygiene, hock injuries, and free stall usage on US dairy farms. *Journal of Dairy Science* 93: 4668-4676.

#### 4. Lying and walking surfaces for cattle, pigs and poultry

- Lowe, D.E., Steen, R.W.J., Beattie, V.E. and Moss, B.W., 2001. The effects of floor type systems on the performance, cleanliness, carcass composition and meat quality of housed finishing beef cattle. *Livestock Production Science* 69: 33-42.
- Lyons, C.A.P., Bruce, J.M., Fowler, V.R., and English, P.R., 1995. A comparison of productivity and welfare of growing pigs in four intensive systems. *Livestock Production Science* 43: 265-274.
- Magnusson, M., Herlin, A. and Ventorp, M., 2008. Short Communication: Effect of alley floor cleanliness on free-stall and udder hygiene. *Journal of Dairy Science* 91: 3927-3930.
- Martrenchar, A., Boilletot, E., Huonnic, D. and Pol, F., 2002. Risk factors for foot-pad dermatitis in chicken and turkey broilers in France. *Preventive Veterinary Medicine* 52: 213-226.
- Mouttotou, N., Hatchell, F.M., and Green, L.E., 1998. Adventitious bursitis of the hock in finishing pigs: prevalence, distribution and association with floor type and foot lesions. *Veterinary Record* 142: 109-114.
- Mouttotou, N., Hatchell, F.M. and Green, L.E., 1999. Foot lesions in finishing pigs and their associations with the type of floor. *Veterinary Record* 144: 629-632.
- ÖKL, 2010. Liegeboxenlaufstall für Milchvieh und Nachzucht. ÖKL-Merkblatt Nr. 48, Vienna, Austria.
- Phillips, C.J.C. and Morris, I.D., 2001. The locomotion of dairy cows on floor surfaces with different frictional properties. *Journal of Dairy Science* 84: 623-628.
- Platz, S., Ahrens, F., Bendel, J, Meyer, H.H. and Erhart, M.H., 2008. What happens with cow behavior when replacing concrete slatted floor by rubber coating: a case study. *Journal of Dairy Science* 91: 999-1004.
- Pouteaux, V.A., Christison, G.I. and Stricklin, W.R., 1983. Perforated floor preference of weaning pigs. *Applied Animal Ethology* 11: 19-23.
- Rantzer, D. and Svendsen, J., 2001. Slatted versus solid floors in the dung area: comparison of pig production system (moved vs. not moved) and effects on hygiene and pig performance, weaning to four weeks after weaning. *Acta Agriculture Scandinavica Sweden Section A: Animal Science* 51: 175-183.
- Reithmeier, P., 2002. Bacterial Load of Several Lying Area Surfaces in Cubicle Housing Systems on Dairy Farms and its Impact on Milk Quality. Inaugural-Dissertation, Universität Bern, Switzerland.
- Rushen, J. and de Passillé, A.M., 2006. Effects of roughness and compressibility of flooring on cow locomotion. *Journal of Dairy Science* 89: 2965-2972.
- Rushen, J., Haley, D. and de Passillé, A.M., 2007. Effect of softer flooring in tie stalls on resting behavior and leg injuries of lactating cows. *Journal of Dairy Science* 90: 3647-3651.
- Schrade, S. and Zähler, M., 2008. Einstreu in Liegeboxen für Milchvieh. Kompost und Feststoffe aus der Separierung von Gülle als Alternative zur Stroh-Mist-Matratze. ART-Berichte Nr. 699, Tänikon, Switzerland.
- Schulze-Westerath, H., Gygax, L., Mayer, C. and Wechsler, B., 2007. Leg lesions and cleanliness of finishing bulls kept in housing systems with different lying area surfaces. *The Veterinary Journal* 174: 77-85.
- Scott, K., Chennells, D.J., Campbell, F.M., Hunt, B., Armstrong, D., Taylor, L., Gill, B.P. and Edwards, S.A., 2004. The welfare of finishing pigs in two contrasting housing systems: fully-slatted versus straw-bedded. *Livestock Science* 103: 104-115.
- Shanawany, M.M., 1992. Influence of litter water-holding capacity on broiler weight and carcass quality. *Archiven Geflügelkunde* 56: 177-179.
- Somers, J.G., Frankena, K., Noordhuizen-Stassen, E.N. and Metz, J.H.M., 2003. Prevalence of claw disorders in Dutch daily cows exposed to several floor systems. *Journal of Dairy Science* 86: 2082-2093.
- Somers, J.G., Schouten, W.G., Frankena, K., Noordhuizen-Stassen, E.N. and Metz, J.H.M., 2005. Development of claw traits and claw lesions in daily cows kept on different floor systems. *Journal of Dairy Science* 88: 110-120.

- Telezhenko, E. and Bergsten, C., 2005. Influence of floor type on the locomotion of dairy cows. *Applied Animal Behaviour Science* 93: 183-197.
- Telezhenko, E., Bergsten, C., Magnusson, M. and Nilsson, C., 2009. Effect of different flooring systems on claw conformation of dairy cows. *Journal of Dairy Science* 92: 2625-2633.
- Telezhenko, E., Bergsten, C., Magnusson, M., Ventorp, M. and Nilsson, C., 2008. Effect of different flooring systems on weight and pressure distribution on claws of dairy cows. *Journal of Dairy Science* 91: 1874-1884.
- Tucker, C.B., Weary, D.M., de Passillé, A.M., Campbell, B. and Rushen, J., 2006. Flooring in front of feed bunk affects feeding behavior and use of free stalls by dairy cows. *Journal of Dairy Science* 89: 2065-2071.
- Van der Tol, P.P.J., Metz, J.H.M., Noordhuizen-Stassen, E.N., Back, W., Braam, C.R. and Weijs, W.A., 2005. Frictional forces required for unrestrained locomotion in dairy cattle. *Journal of Dairy Science* 88: 615-624.
- Vermunt, J.J. and Greenough, P.R., 1996. Claw conformation of dairy heifers in two management systems. *British Veterinary Journal* 155: 157-180.
- Von Wachenfelt, H., 2009. Effect of floor condition on pig gait: a kinematic and kinetic study. Doctoral thesis, Swedish University of Agricultural Sciences, Uppsala, Sweden.
- Waldenstedt, L. 2006. Nutritional factors of importance for optimal leg health in broilers: a review. *Animal Feed Science and Technology* 126: 291-307.
- Weary, D.M. and Taszkun, I., 2000. Hock lesions and free-stall design. *Journal of Dairy Science* 69: 177-188.
- Webb, N.G. and Nilsson, C., 1983. Flooring and injury – an overview. In: Baxter, S.H., Baxter, M.R. and MacCormack, J.A.D. (eds.) *Farm animal and welfare*. Martinus Nijhoff, The Hague, the Netherlands, pp. 226-259.
- Wechsler, B., Schaub, J., Friedli, K. and Hauser, R., 2000. Behaviour and leg injuries in dairy cows kept in cubicle systems with straw bedding or soft lying mats. *Applied Animal Behaviour Science* 69: 189-197.
- Wright, A.I., Osborne, A.D., Penny, R.H.C. and Gray, E., 1972. Foot-rot in pigs: experimental production of the disease. *The Veterinary Record* 90: 93-99.
- Zdanowicz, M., Shelford, J.A., Tucker, C.B., Weary, D.M. and Von Keyserlingk, M.A.G., 2004. Bacterial populations on teat ends of dairy cows housed in free stalls and bedded with either sand or sawdust. *Journal of Dairy Science* 87: 1694-1701.
- Zoric, M., Nilsson, E., Lundeheim, N. and Wallgren, P., 2009. Incidence of lameness and abrasions in piglets in identical farrowing pens with four different types of floors. *Acta Veterinaria Scandinavia* 51: 23.
- Zurbrigg, K., 2006. Sow shoulder lesions: risk factors and treatment effects on an Ontario farm. *Journal of Animal Science* 84: 2509-2514.



## 5. Housing of sows during farrowing: a review on pen design, welfare and productivity

L.J. Pedersen, J. Malmkvist and H.M.L. Andersen  
Department of Animal Science, Aarhus University, Blichers Allé 20, P.O. Box 50, 8830 Tjele,  
Denmark; [Lene.JuulPedersen@agrsci.dk](mailto:Lene.JuulPedersen@agrsci.dk)

### Abstract

Housing of sows during farrowing occurs mainly in farrowing crates where the sows are confined between bars without the possibility to turn around. The existing farrowing crates are associated with a number of negative welfare consequences for sows. Furthermore, breeding more piglets in the litter, combined with the fact that sows have generally become both longer and wider over the past 15 years, means that the size of the current crates is not large enough neither to accommodate the sow nor piglets until 4 weeks after birth. Therefore, alternatives to the current farrowing crate are necessary. Pens for loose housed sows are good alternatives for the sake of sow welfare. Review of the existing literature does not suggest that loose housing is associated with higher general piglet mortality than housing in farrowing crates. Knowledge from studies on behavioural needs of sow and piglet during farrowing and lactation is reviewed and used to make general recommendations on pen design. From this knowledge, prototypes of farrowing pens have been developed and are currently tested in smaller scale in production herds. Through this, more experience is being gathered on the pens' function in practice that contribute to having the first prototypes adapted and further developed so that they become an attractive alternative to the farrowing crate for the farmer both economically and with regard to animal welfare.

**Keywords:** farrowing crates, loose-housing, piglet mortality, behaviour, stress, thermoregulation

### 5.1 Background

In the 1960s to 1970s, the farrowing crate became a fast growing sow housing method worldwide. First of all, the farrowing crate saved space and allowed easy manure handling through slatted flooring behind the sow. Based on production experiments in commercial herds, the farrowing crate seemed not to increase mortality rate and was thus found economically competitive with the traditional pen system in Denmark (Pedersen and Ingvarsten, 1981) and other countries (Gustafsson, 1983). Currently, the majority of sows in the EU are housed in crates during farrowing and lactation (EFSA, 2007). The farrowing crate consists of a pen within which bars have been set up to prevent the sow from turning around. Outside the bars there is a separate space for the piglets and in some systems a roof covered creep area is situated in a corner of the pen. Usually, the creep area is installed with either floor heating and/or radiant heating from an infra-red lamp. There is no international survey on the size and design of currently used farrowing crates. A Danish survey reported by Pedersen *et al.* (2010) measured the size and design of farrowing crates in 84 Danish herds. The median size of the farrowing crates was 3.95 m<sup>2</sup> (25-75% quartile: 3.75-4.25 m<sup>2</sup>). The median length of the bars crating the sows measured from the rear end of the through was 198 cm (25-75% quartile: 190-200 cm), while the median width at the front part of



the sow was 57 cm (25-75% quartile: 55-60 cm) while the median width at the rear end of the sow was 64 cm (25-75% quartile: 58-70 cm). The pens had either fully slatted floor (11 out of 84) or partly slatted floor. Straw or saw dust was given in some herds to the piglets usually out of reach of the sow (21 herds out of 84 herds gave chopped straw or saw dust to the piglets).

Due to current public concern about animal welfare there is, however, a growing pressure on the pig industry to change the crate system to a pen system where sows are kept loose. However, at the moment, Sweden, Norway, and Switzerland are the only countries where the farrowing crate is banned. The pig industry is concerned about increased piglet mortality and increased cost due to space and labour if the crate system will be banned. Therefore, many countries have encouraged and initiated research on farrowing systems for loose housed sows.

In the present review, the welfare consequences of crating the sows are considered and current knowledge of design and productivity in farrowing pens for loose housed sows is reviewed.

## **5.2 Welfare consequences of the farrowing crate**

When kept under free range conditions, sows will isolate themselves from the rest of the herd a few days prior to farrowing and choose a sheltered location where they can build a nest. Nest building consists of several phases. First, the sow makes an indentation in the ground, then it collects and organizes the nesting material and finally, a few hours before farrowing, the sow will go into the nest where she lies quietly until the piglets are born (Jensen, 1986; Jensen *et al.*, 1993; Stolba and Wood-Gush, 1989). From approx. 24 h before farrowing endogen stimuli motivates the sow highly for nest building and sows will nest build intensively until a few hours before farrowing (Wischer *et al.*, 2009a).

If the sows, however, are crated the ability to demonstrate actual nesting behaviour is very limited and is seen primarily as increased restlessness and redirected nesting activity against the equipment (Damm *et al.*, 2003; Hartsock and Barczewski, 1997; Jarvis *et al.*, 1997, 2001; Weber and Troxler, 1988) or as oral/nasal stereotypies (Weber, 1984; Damm *et al.*, 2003). They have also no control over selection of a nest site, which contains the qualities preferred by sows in terms of for example isolation (Jensen, 1986; Stolba and Woodgush, 1984). Lactating sows will leave the nest site for dunging (Andersen and Pedersen, 2011; Damm and Pedersen, 2000; Pajor *et al.*, 2000; Schmid, 1992) while crated sows are forced to dung at the nest site. Besides, crating even has a negative effect on sows' possibility to thermoregulate. Sows have an increased preference for lying on a cool surface (Phillips *et al.*, 2000) concurrently with their heat production being increased by increasing feed intake and milk yield as the lactation proceeds. Crated sows are thus susceptible to heat stress as they have limited possibilities to thermoregulate (Prunier *et al.*, 1997; Quiniou and Noblet, 1999).

Crating during the gestation period has been shown to affect strength of muscles (Marchant and Broom, 1996) and reduce cardiovascular fitness (Marchant *et al.*, 1997) and bone strength (Marchant and Broom, 1996). Crating during farrowing and lactation most likely will have similar effects. However, the effects may be less extensive due to the shorter period of confinement. Negative effects of crating on lesions of hoof and leg and on the maintenance of muscle mass

## 5. Housing of sows during farrowing: a review on pen design, welfare and productivity

are often reported as a consequence of the lack of movement over time (Barnett *et al.*, 2001). Leeb *et al.* (2001) have suggested that the inability to move around is the cause of the increased incidence of thickening of the skin (callosities) seen in crated sows. In addition to the physical consequences of crating during farrowing and lactation, also stress responses such as increased heart rate (Damm *et al.*, 2003) and increased plasma concentration of the stress hormone cortisol are seen in crated sows compared to loose housed sows before (Jarvis *et al.*, 1997; Lawrence *et al.*, 1994); and after farrowing (Oliviero *et al.*, 2008). During lactation Jarvis *et al.* (2006) found that plasma levels of cortisol after a CRH injection (a hormone that via ACTH stimulates adrenal secretion of cortisol) on day 29 of lactation were higher in the crated sows than in the loose housed sows, indicating that also persistent crating has negative effects on sow welfare.

From the year 2013, all sows in the EU must be kept loose in groups throughout gestation. This probably means that the long term negative effects of crating will be reduced (such as reduced muscle and bone strength) whereas the more immediate stress response to crating will be increased each time the sows are moved to the farrowing crate (Boyle *et al.*, 2000). The latter may result in prolonged birth (Oliviero *et al.*, 2008, 2010) and increased risk of still birth particularly in young gilts that are confined for the first time (Cronin *et al.*, 1996; Pedersen and Jensen, 2008).

### 5.3 Space for sow and piglets in farrowing crates

Crated sows will often bump against the equipment when they get up and lie down (Troxler and Weber, 1989; Harris and Gonyou, 1998) indicating disrupted getting up and lying down behaviour. In a Danish survey on 10 farms with crated sows, it was found by examination of 550 sows, that 41% showed deviating lying-down behaviour that was often associated with lameness (Bonde *et al.*, 2004). A similar study has not been carried out on penned sows. Taylor *et al.* (1988), however, reported that crated gilts compared with loose housed gilts rose fewer times, lay more down for longer periods, and changed posture more frequently when lying down. Anil *et al.* (2002) described that the available space within bars affected sows' getting up and lying down behaviour. Large sows took longer time to lie down and were lying down longer time than small sows when space was identical.

According to the EU directive 2001/93/EC 'pens must be designed so that each pig can lie down as well as rest and get up without difficulty'. Measurements of both the dynamic and static space used by sows, indicate that to allow undisturbed getting up, lying down and resting, space between the bars must be at least 220 cm in length and 80-90 cm in width (Baxter and Schwaller, 1983; Curtis *et al.*, 1989; McGlone *et al.*, 2004; Moustsen *et al.*, 2004).

Moustsen *et al.* (2004) measured the physical dimension of 368 Danish cross bred sows. Since the dimension of the equipment should be able to accommodate all sows the 95% quartile should be considered and was measured to be 202 cm in length, 47 cm in shoulder width and 71 cm in depth. The dynamic space used for getting up and lying down was measured to be approximately 32 cm in width and 16 cm in length in addition to the sows' own dimensions (Moustsen and Duus, 2006). When this is compared to the dimension of the farrowing crates (in average approximately 198×60 cm, see background section for details) space in conventional crates is both too narrow

in length and width in order for the sows to perform an undisturbed getting up and lying down movement.

Piglets may also be subjected to some space problems due to the dimensions of the farrowing pen (Figure 5.1). The EU directive 2001/93/EC states that 'if a farrowing crate is used, piglets must have sufficient space to suck without difficulty'. To accommodate this for 95% of (Danish) sows in all situations, pens must be at least 202 cm wide: 90 cm between the bars and 56 cm to both sides. The 56 cm is what an average piglet was measured to be in length at week 4 of age (Moustsen and Poulsen, 2004a). The length of the pens should be at least 280 cm long: 220 cm to accommodate 95% of (the Danish) sows including dynamic space for movements, 30 cm in front to the trough and at least 30 cm (length of an underarm) to facilitate farrowing assistance (see Figure 5.2). In addition, part of the flooring should also according to the EU directive be 'large enough for all piglets to rest on it at the same time, must be solid floor or covered with a mat or straw or other suitable material'. This would, according to measurements (Moustsen and Poulsen, 2004b) of 4 weeks old piglets in semi-lateral laying, require that at least 1.1 m<sup>2</sup> was solid or covered by straw or mats to accommodate 10 piglets, a common litter size at weaning.

If the above conditions in the EU directive must be fulfilled in the farrowing crate, its measures must therefore be at least 5.6 m<sup>2</sup> (200 cm width × 280 cm length) based on the above arguments. Of this area, at least 1.1 m<sup>2</sup> must be solid floor, separated from the sow, where the piglets can rest. Sow space must make up approx. 2 m<sup>2</sup> (90×220 cm) of the total area (Figure 5.2).



*Figure 5.1. Photo of a common farrowing crate with space restriction. The picture illustrates problems with limited space for the piglets to suckle. The piglets at the picture are almost new-born. In addition, the space in length is too small resulting in the sow resting its head on the trough due to limited space in the length of the crate.*

## 5. Housing of sows during farrowing: a review on pen design, welfare and productivity

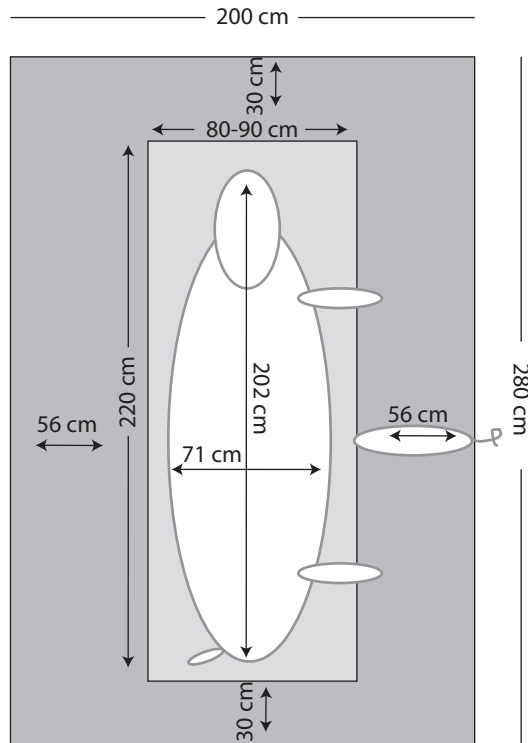

Figure 5.2. Schematic drawing of the estimated dimensions of farrowing crates that allow enough space for physical dimension of sow and piglets as well as for dynamic movements for getting up and lying down. The measures are based upon the 95% quartile of the physical dimensions and space used for movements of Danish cross bred production sows and the 95% quartile of length of piglets at 4 weeks of age.

Practical experiences, however, suggest that this much space between the farrowing bars can result in small sows turning around in the crate, which will result in malfunctioning of the crate. Therefore, it may be necessary to consider different sized crates for small and large sows.

### 5.4 Piglet mortality in relation to housing

#### 5.4.1 Overall mortality

Despite the fact that the crate system has been considered to reduce piglet mortality mainly through a reduction of crushing, there is not much scientific evidence for this when considering the few large surveys that compare the mortality rate in commercial herds. An older Swedish herd study (Gustafsson, 1983) showed no difference in piglet mortality between crated and loose sows (crated 18.74%, n=15,607 vs. loose 18.75%, n=56,900 litters). Similar results were found in Danish herds around the same period (Pedersen and Ingwersen, 1981), with no differences between loose and crated sows either (crated sows in pens with fully drained floor 10.2%, n=1,085

vs. loose sows 10.5%, n=697). Bäckström *et al.* (1994), however, found a slightly higher piglet mortality in litters with crated sows compared to litters with loose housed sows (crated 18.7%, n=765 vs. loose 16.9%, n=3,219). In a more recent Danish study (Moustsen and Poulsen, 2004b), the number of weaned piglets was compared in one herd, consisting of both crated and loose sows. There was no difference in the number of weaned piglets (average of 10.4 piglets per litter) between the two pen systems (crates n=288 and loose n=284, respectively). O'Reilly *et al.* (2006) examined risk factors associated with high piglet mortality in 67 herds in England and Wales. Piglet mortality was not different between herds with crated sows and loose sows whether indoor or outdoor. The average mortality was 10.7% of live births. However, there were only few herds with indoor loose sows. In a large survey from commercial herds in Switzerland, the production data from 482 herds with crated sows was compared with data from 173 herds with loose sows (total 44,837 farrowings) (Weber *et al.*, 2007). There was no difference between herds with crated and loose sows in the number of piglets that died after farrowing (crates 1.42 per litter vs. loose 1.40 per litter; average number of live born piglets: 11.0, average number of stillborn piglets: 0.6). A recent cohort study (KilBride *et al.*, 2012) on commercial pig farms in UK confirmed the results of the study in Switzerland. They also found no difference between farms with crated sows (n=49 farms) and farms with penned sows (n=15 farms) either in the percentage of live born mortality (crates 11.7% vs. loose 10.9%) or in the percentage of stillborn piglets (crates 7.2% vs. loose 8.3%).

#### **5.4.2 Significance of litter size on piglet mortality**

Many studies have shown that the proportion of dead piglets is increasing with increasing litter size both in pens and crates (Pedersen *et al.*, 2006; Roehe and Kalm, 2000; Su *et al.*, 2007; Weber *et al.*, 2007). Whether the influence of litter size is stronger in pens than in crates or *vice versa* has to our knowledge not been analysed.

#### **5.4.3 Causes of piglet mortality**

##### *Stillborn piglets*

The birth is one of the biggest challenges for the yet unborn piglets as the proportion of stillborn piglets is the largest source to losses in sow production. In herd studies, still birth is often reported to be around 5-11% of total born piglets (KilBride *et al.*, 2012; Su *et al.* 2007; Weber *et al.*, 2007). KilBride *et al.* (2012) found no difference in risk of still birth between indoor housed crated sows and loose sows. However, the risk of still birth was lower in outdoor housed sows compared to indoor housed sows. In indoor housed sows, both Cronin *et al.*(1996) and Gustaffson (1983) found increased risk of still birth in gilts crated for the first time compared to penned gilts. Also Pedersen and Jensen (2008) found more still births in crated gilts compared to loose gilts. However, in their study, all gilts were introduced to the farrowing house close to the time of farrowing. Stillborn piglets are more likely to be born after long birth intervals and may thus have suffered from anoxia during birth (Pedersen *et al.*, 2006). Prolonged stays in the birth canal is not only a risk to stillborn piglets but do also increase the live born piglets' risk of dying from other causes (e.g. illness, poor growth, etc.) (Pedersen *et al.*, 2006). Confinement in farrowing crates has been shown to induce physiological stress responses in sows that may affect the progress of farrowing through inhibition of oxytocin (Jarvis *et al.*, 1997; Lawrence *et al.*, 1992, 1994;

## 5. Housing of sows during farrowing: a review on pen design, welfare and productivity

Oliviero *et al.*, 2008). Such mechanism may explain the prolonged birth intervals (Biensen *et al.*, 1996; Oliviero *et al.*, 2008, 2010; Pedersen and Jensen, 2008; Wülbers-Mindermann *et al.*, 2002) and increased number of stillborn piglets occurring in crated sows compared to loose sows; particularly in young gilts that are confined for the first time (Cronin *et al.*, 1996; Gustafsson, 1983; Pedersen and Jensen, 2008).

### *Savaging by the sow at birth*

Savaging is observed both in gilts and older sows and is considered an abnormal behaviour characterized by general agitation during birth (Ahlstrom *et al.*, 2002; Chen *et al.*, 2008) but tend to be more common in gilts than in older sows (Chen *et al.*, 2008; Harris and Gonyou, 2003; Marchant Forde, 2002). While Jarvis *et al.* (2004) found increased savaging in crated sows compared to loose housed sows, Pedersen *et al.* (2011) found no difference between the systems, while Marchant Forde (2002) found more savaging in pens compared to crates. No comparison between crates and pens has been performed with a large sample size and the results are non-conclusive.

### *Crushing*

Crushing is the second largest contribution to mortality both in farrowing crates and loose house pens. However, it is difficult to evaluate if crushing is the primary cause of death since weak and hypothermic piglets will be more susceptible to crushing since they do not respond towards the sow's movements. In addition, in loose housed sows it is likely that sows lie on already dead piglets and that these are also mistakenly categorized as crushed. Pedersen *et al.* (2011) found in a controlled experimental study of dead piglets from 104 gilts (crated sows n=55, loose sows n=50) that 5.4% of the total number of born piglets died as a result of crushing. This categorization was based on a combination of autopsy and verification of the death on video. In the previously mentioned farm survey from Switzerland by Weber *et al.* (2007), less piglets were categorized by the farmer as dead due to crushing in the crate compared to the loose house pens (0.52 vs. 0.62 piglets per litter), while more piglets from crated sows were categorized as dead due to other causes (0.89 vs. 0.78 piglets per litter). Similar results were found by KilBride *et al.* (2012), who reported lower incidence of crushing in crates compared to loose house systems (crates 4.6% vs. loose 6.0%). In contrast, more piglets died from other causes in crates (crates 6.7% vs. loose 4.4%). In another farm study of 146 sows (Cronin *et al.*, 2000), the farmer categorized a smaller proportion of the dead piglets as crushed by the sows in the crates compared to pens (crates 20% vs. loose 45%,  $P=0.06$ ) while a larger proportion were categorized as dead due to being categorized as weak and small (crates 24% vs. loose 14%,  $P=0.08$ ). Thus it seems uncertain that the difference in causes of death found in herd surveys is due to a genuine difference between crates and pens. The recorded difference may be related both to the farmer's subjective observations of death causes in the two systems or to the fact that a loose sow is more likely to lie down on weak or already dead piglets than is the case for a crated sow.



### *Hypothermia and starvation*

Apart from stillborn piglets and crushed piglets, piglets are dying from hypothermia and starvation. However, it is difficult to distinguish the triggering cause of death when it comes to piglets that have died due to crushing, hypothermia and starvation as starvation and hypothermia often precede crushing. Hypothermia 2 hours after birth was thus a significant risk factor for piglets to be recorded as dying from crushing, starvation, and diseases both in crates and indoor pens (Pedersen *et al.*, 2011; Tuchscherer *et al.*, 2000), as well as in outdoor systems (Baxter *et al.*, 2009).

### *Diseases*

It is difficult to specify how many piglets die from diseases because it depends on the individual herd's health status and the current infection risk. There are no studies indicating a different risk of death due to diseases between crates and pens.

## **5.5 Design of farrowing pens for loose housed sows**

### **5.5.1 Prevention of crushing**

Most crushing in loose house pens occurs in connection with the sows lying down without support of the walls. Marchant *et al.* (2001) reported that the risk of a piglet to be squeezed to death when the loose sow lie down in a pen was only 0.5% when the sow lie down against a wall, whereas it was 14% when the sow lie down without support from a wall. The wall may support the lying down movement to be more slow and controlled. A pen design which ensures that the sows use support wherever possible when lying down can, therefore, be expected to reduce piglet mortality. Loose house pens are typically designed with a rail on all walls to prevent the sow from squeezing the piglets against the wall when she lies down. However, Damm *et al.* (2006) showed that sows preferred to lie against a rail-free wall compared to a wall equipped with a farrowing rail at the bottom of the wall. In their study, sows did not differentiate between using sloping walls vs. straight walls, or between ribbed vs. plain walls for supporting lying behaviour. Thus a sow is more attracted to use support when the walls are free from farrowing rails. In order still to maintain an escape zone for the piglets there should be both an outer and an inner wall. In that way piglets avoid being crushed against the wall, which further benefits survival (Figure 5.3).

It is difficult, though, to completely avoid that sows lie down without support. Therefore, reducing the risky behaviour in these situations also should be considered through the stimulation of maternal behaviour. Sows are strongly motivated for nest-building. The nesting behaviour is considered to be influenced both by internal and external stimuli and is important for maternal behaviour after birth (see review by Wischner *et al.*, 2009a). It has generally been found that high activity during nesting (Andersen *et al.*, 2005; Pedersen *et al.*, 2006; Wischner *et al.*, 2009b) and low activity during parturition (Thodberg *et al.*, 2008) are associated with a reduced risk of crushing. Access to straw can stimulate nesting activity (Thodberg *et al.*, 1999). Damm *et al.* (2010) showed that the number of crushing situations was reduced in sows with free access to straw. Herskin *et al.* (1998) found that sows during parturition were calmer when having access

## 5. Housing of sows during farrowing: a review on pen design, welfare and productivity

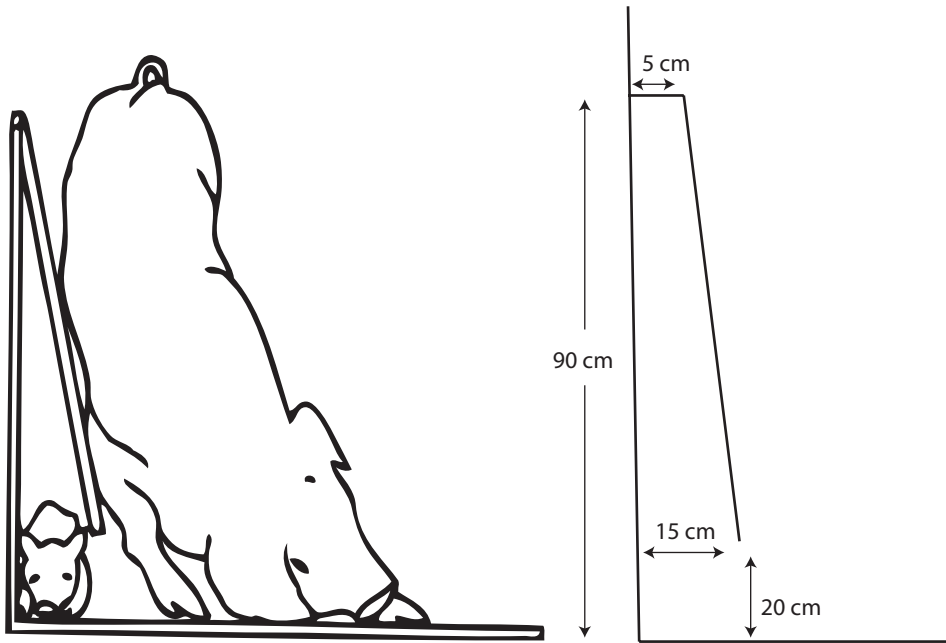

Figure 5.3. Sloping walls with escape zones for piglets. The walls attract the sow to use support during lying down. The double wall protects the piglets from being crushed against the wall. To the right, the dimension of the walls and escape zone is given by Moustsen (2006).

to straw and Pedersen *et al.* (2003) reported that feedback from a nest resulted in the new-born piglets being quicker to find teats and thus gaining earlier access to colostrum. Other types of nesting materials may have the same effects, but have not been investigated to the same extent as straw. For example, Damm *et al.* (2000) found that nesting behaviour was terminated sooner before birth with access to braches than without. Burri *et al.* (2009) have compared whole straw with chopped straw for nesting. They found significantly more nesting activity directed towards the equipment (indicative of redirected behaviour) when chopped straw was provided compared to whole straw. Furthermore, there were significantly more dangerous situations on day 1 after farrowing in litters where the sow had access to chopped straw compared to whole straw. On this background, we conclude that access to adequate straw can improve maternal behaviour of importance for piglet crushing in loose housed sows. The sows' use of straw was estimated based upon the daily removal of straw (unpublished data) from straw rack in pens of 69 sows involved in three experiments (Damm *et al.*, 2010; Pedersen and Jensen, 2008; Pedersen *et al.*, 2007a). In average the sows removed approx. 0.5 kg of whole straw daily before and after farrowing. On the nesting day, however, the sows used an average of approx. 1.5 kg of whole straw with a variation from less than 0.5 kg and up to 7.5 kg.



### 5.5.2 Space for sow and piglets

To avoid crushing and optimize the piglets' milk intake, it is necessary with sufficient space in the farrowing pen for the sow to lie down easily, for the piglets to suckle without being hindered by the equipment and for all piglets to rest in the heated piglet area simultaneously. For example, Cronin *et al.* (1998) found that smaller and narrow compared to larger and wider nest sites induced more restless postural changes in sows and reduced the time piglets spent at the udder during nursing. As for the crate system, the physical dimension of sow and piglets is important to incorporate in the pen design together with the dynamic space used for getting up and lying down.

### 5.5.3 Thermal comfort of sow and new-born piglets

Significant challenges are connected to designing the farrowing environment so that both the sow's and piglets' thermal needs are met as the sows' upper critical thermal limit has been reported to be at 22 °C, whereas the new-born piglets' zone of comfort is above 34 °C. In traditional farrowing crates, piglets' thermal need has been considered, partly by keeping the room temperature relatively high (around 20-22 °C) and partly by providing additional heat in a separate piglet corner. A number of studies have shown that new-born piglets do not use such a heated corner extensively until 2-3 days after initiation of parturition (Hrupka *et al.*, 2000a,b). At this later point in time, however, the piglets are less prone to hypothermia. Malmkvist *et al.* (2006) showed that the additional floor heating (35 °C) from approx. 10 h after the start of nest building to 2 days after start of farrowing increased the piglets' ability to maintain normal body temperature just after birth, it reduced time to first colostrum intake and increased the piglets' chance of survival. Piglets with floor heating at the birth site until 48 h after birth of first piglet used the heated piglet corner later and to a lesser extent than piglets that only had heat in this area of the pen (Houbak *et al.*, 2006). In spite of this, the piglet's chances of survival increased significantly in pens with floor heating (with heat 8.7% dead of live born, without heating 15.8% dead of live born). A recent study has shown that the duration of the floor heating can be reduced from 48 h to 12 h without negative effects on the piglets' body temperature at 24 h or 48 h after birth (Pedersen *et al.*, 2013). Even with floor heating in the pens, the room temperature is of great importance for the development in piglets' body temperature. Piglets born at 25 °C vs. 15 °C and 20 °C had only a slight drop in body temperature after birth and a rapid increase to 37 °C. Even at 24 h and 48 h after birth, piglets' rectal temperature was still higher at a room temperature of 25 °C and 20 °C than of 15 °C (Pedersen *et al.*, 2013). After the early postnatal period, the piglets' use of the creep was significantly higher at low than at high room temperatures. When the room temperature was 15 °C and to a lesser extent when it was 20 °C the use of the creep also increased within 6 h after turning off the floor heat. However, the percentage of piglets that used the creep area was still below 20% during the first 24 h after birth of first piglet even at the cold room temperature and without floor heating. Taken together, these results indicate that a heated creep (1) may have an important thermoregulatory function for the piglets, being dependent on the outer temperature, but (2) is not sufficient to accommodate the heat requirements of all piglets, especially during the early postnatal period, during which the risk of hypothermia and dying is increased.

## 5. Housing of sows during farrowing: a review on pen design, welfare and productivity

Provision of floor heating in pens makes the question of whether sows are exposed to heat stress important. Malmkvist *et al.* (2009) found increased plasma concentration of stress hormones in sows housed in pens with floor heating in the entire pen. This was, however, not to such an extent that it affected the sows' immune response (Damgaard *et al.*, 2009), farrowing course or blood concentrations of oxytocin (Malmkvist *et al.*, 2009). Using only partly heated floor in a recent study showed that sows had an increased respiratory rate, body temperature and surface temperature with increasing room temperatures combined with floor heating. The sows used the unheated slatted floor to cool, but without affecting the choice of farrowing site, which primarily took place on the solid – and heated (35 °C) – floor (Malmkvist *et al.*, 2012). Overall, there was an equal high feed intake during the first 21 d of lactation at the high and low temperatures. There was no weight loss of the sows at any of the three room temperatures, suggesting that loose housed sows were able to adapt to the higher room temperatures (25 °C) throughout the lactation (Malmkvist *et al.*, 2012). The relative high feed intake in loose housed sows during warm room temperatures contrasts results previously reported in crated sows, from which reduced feed intake and lactation weight loss typically are reported following room temperatures above 22 °C during lactation (Prunier *et al.*, 1997; Quiniou and Noblet, 1999).

In addition, Pedersen *et al.* (2007b) and Phillips *et al.* (2000) showed that sows during the first 2 to 3 days after farrowing preferred to lie on a heated floor over an unheated floor, even at high room temperature (Malmkvist *et al.* 2012). These results indicate that partly floor heating will not result in sows giving birth to piglets at the slatted floor area and is therefore a possible option to improve the thermal environments at the birth place of loose housed sows and at the same time improve thermal comfort and viability of the new-born piglets.

### *Zone division of the farrowing pen*

In order to obtain a good hygiene in a farrowing pen it is essential that the sows are able to divide the pen into zones of resting/farrowing and of dunging. The dunging area can then be built with slatted floor to assure easy manure handling. When given the opportunity, sows clearly zoned a farrowing pen (Damm and Pedersen, 2000; Damm *et al.*, 2010) into a nesting area and a dunging area. An attractive 'lie down' wall can additionally motivate the sow to lie down in a certain part of the pen (Damm *et al.*, 2006). This part of the pen should include good conditions for the piglets, as for example a heated solid floor during farrowing as mentioned above and/or straw. Likewise, even though slatted floor is used for lying during periods with high temperatures, the sows still successfully divide the pen into zones for farrowing and nursing (solid floor) vs. zones for thermoregulation and elimination (slatted floor) (Malmkvist *et al.* 2012). Another way to attract the sow to a specific area of the pen could be to create some kind of isolation from neighbouring sows, as sows prefer to farrow in a visual enclosed area for example by solid walls to neighbouring pens (Hunt and Petchey, 1989). Other types of screening or covering may also attract the sow to a specific farrowing site, e.g. a roof covered pen (Phillips *et al.*, 1991; Sancha and Arey, 1995); even though Damm *et al.* (2010) did not demonstrate any preference of sows to farrow under a non-solid roof cover, maybe due to factors such as position in height and/or texture. Another element controlling the sow's choice of resting and dunging area is the location of the feeders. Sows prefer to dung away from the feeders and will go as far away from the feeder as possible placing themselves with their head turned away from the feeder (Andersen and Pedersen, 2011).

The study showed that the sows were dunging with their head turned away from the resting area and away from feeders in 75% of all dunging events.

## **5.6 Design of farrowing pens for loose housed sows**

Based on the knowledge about sows' behaviour, physiological responses and preferences during farrowing and knowledge about what triggers risky situations for neonatal piglet mortality, it is possible to specify recommendations for the design of farrowing pens for loose housed sows, taking both improved animal welfare and high productivity into consideration. We recommend that, in order to meet the needs of sows and piglets, farrowing and lactation housing are designed according to the following principles:

- Loose housing of sows during the entire reproductive cycle as this reduces stress during parturition thereby increasing the chance of easy delivery with fewer stillborn piglets.
- Provision of additional heat sources for the new-born piglets such as floor heating at the birth site and/or increased room temperature around farrowing up to 25 °C, present at the time of birth of first piglet in the litter. This heat supply has largest positive impact on piglet vitality during the first 12 h of life.
- Establishment of a closed area in the pen with solid floor and solid walls (or other means) to reduce disturbances from neighbours. This creates the possibility for the sow to select an undisturbed area for nesting and resting, and thus optimizing the chances that piglets are born on the thermal favourable solid floor.
- Provision of more than 1 to 2 kg of straw or other nesting material prior to the nest building period to meet the sows' motivation to nest build and further enhance a zone division, improve the thermal climate and help the piglets to dry after farrowing.
- Establishment of walls free from traditional farrowing rails, but with build-in piglet escape zones, in the nesting area to increase zone division and to support sows lying down. In case of limited space in the pen, it may be advantageous to let the inner walls slope inwards in the pen (Figure 5.3). This will result in walls taking up less space at the heights of a standing sow compared to the floor level of the lying sow, and will thus allow more space for the sow when moving around in standing position.
- Establishment of an area with slatted floor and open equipment to the neighbouring pen, in order to make it easier for the sow to zone divide the pen as it prefers to use the enclosed area for resting with piglets and to dung away from this area in the open area with slatted floor. The slatted floor area may also be used for cooling down when room temperatures are high. The slatted floor area should measure no less than a sow's length and no less than 1 m on the short side in order for the sow to be able to turn away from the feed trough during dunging. Thus the manure lands on the slatted floor. In herds with many large sows more space is needed to avoid the faeces to land in the feed trough.
- Placement of feeders and water should be located at the slatted floor. Hereby activity in the nesting area is reduced. Since sows dung away from the feed and away from the nest it is possible to control that the majority of the faeces and urine is positioned on the slatted floor.
- To further improve hygiene and save labour cost for pen cleaning, extra drainage at the floor around the dunging area can be made and/or a small iron rail can be set up to further help

## 5. Housing of sows during farrowing: a review on pen design, welfare and productivity

partitioning the slatted floor area from the concrete floor area and thus preventing the sow from standing diagonally on the slatted floor (Figure 5.4A).

- Establishment of a creep area of at least 1.1 m<sup>2</sup> for the piglets with additional heating turned on after the heating device at the birth site is turned off.

In addition to these recommendations, we generally recommend that the pen is positioned in the room in a way that allows easy overview and access to the piglets. This can for example be achieved by turning the pen so the creep area is facing towards the passage where the entrance to the pen is located. The piglets can now be reached from the passage and unnecessary disturbances of the sows are avoided. In cases where sows need treatments or in cases of aggressive sows we

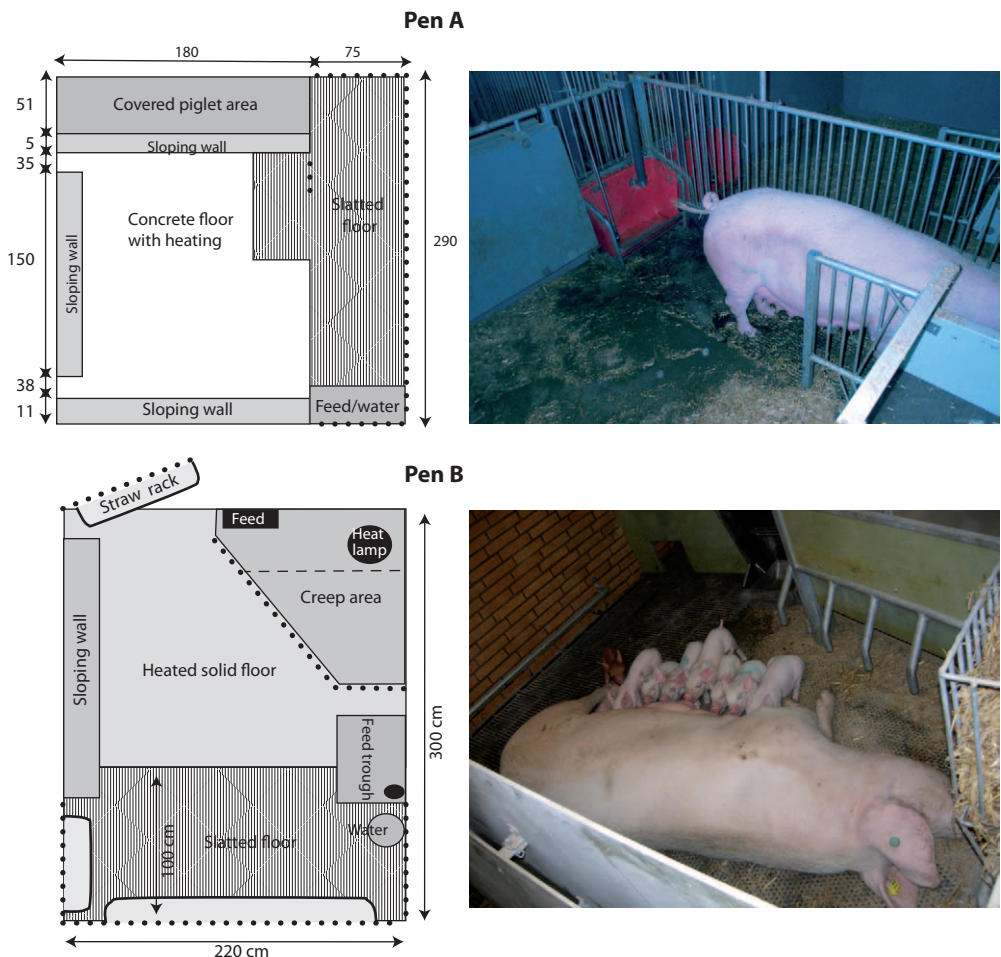

Figure 5.4. Example of pens for loose housed sows designed according to some of the major recommendations in this paper. Pen A measures 7.4 m<sup>2</sup>. The photo of Pen A shows the small rail preventing the rear end of the sow to be above the solid floor during dunging. Pen B measures 6.6 m<sup>2</sup>.

recommend that a device is established that can confine the sow during handling. Examples of pens designed after the above principles are shown in Figure 5.4. Such pens are currently tested in smaller scale in Danish production herds. More experience on the pens' function in practice will be gathered and can contribute to the first prototypes being adapted and further developed so that they become an attractive alternative to the farrowing crate for the farmer both economically and with regard to animal welfare.

## **5.7 Conclusion**

Today, there is abundant knowledge indicating that the traditional farrowing crate has negative impact on sow welfare. At the same time, the majority of the large-scale studies do not indicate that crating significantly reduces piglet mortality compared to well-designed loose house pens. In recent years, much knowledge has been generated, which can be used to design farrowing pens for loose housed sows both respecting piglets, sows and farmer needs. Therefore, there is good opportunity to design farrowing pens for loose housed sows, having the potential to be a competitive alternative to the existing farrowing crate.

## **Acknowledgements**

The authors wish to thank Vivi Aa. Moustsen from Danish Pig Research, Pig Producer Søren Larsen, Jens Agergaard from Jyden Bur A/S, Peter Stougaard from Skiold A/S, Niels Søndergaard from Peerstrup Beton Industry A/S, Preben Høj from Svend Aage Christiansen A/S, Kim Jensen Møller from SKOV A/S, Uffe Mølgård from Erga Floor ApS and Arne Møller from Agri Contact for valuable discussions on functional design of farrowing pens for loose housed sows from the point of view of the farmer and the pig industry in general.

## **References**

- Ahlstrom, S., Jarvis, S. and Lawrence, A.B., 2002. Savaging gilts are more restless and more responsive to piglets during the expulsive phase of parturition. *Applied Animal Behaviour Science* 76: 83-91.
- Andersen, H.M.L. and Pedersen, L.J., 2011. The effect of feed trough position on choice of defecation area in farrowing pens by loose sows. *Applied Animal Behaviour Science* 131: 48-52.
- Andersen, I.L., Berg, S. and Bøe, K.E., 2005. Crushing of piglets by the mother sow (*Sus scrofa*)-purely accidental or a poor mother? *Applied Animal Behaviour Science* 93: 229-243.
- Anil, L., Anil, S.S. and Deen, J., 2002. Relationship between postural behaviour and gestation stall dimensions in relation to sow size. *Applied Animal Behaviour Science* 77: 173-181.
- Bäckström, L., Algers, B., Nilsson, J. and Ekesbo, I., 1994. Effect of sow housing systems on production and health. *Proceedings: The 13<sup>th</sup> International Pig Vet. Soc. Congress, Bangkok, Thailand, 26-30 June*, p 427.
- Barnett, J.L., Hemsworth, P.H., Cronin, G.M., Jongman, E.C. and Hutson, G.D., 2001. A review of the welfare issues for sows and piglets in relation to housing. *Australian Journal of Agricultural Research* 52: 1-28.
- Baxter, E.M., Jarvis, S., Sherwood, L., Robson, S.K., Ormandy, E., Farish, M., Smurthwaite, K.M., Roehe, R., Lawrence, A.B. and Edwards, S.A., 2009. Indicators of piglet survival in an outdoor farrowing system. *Livestock Science* 124: 266-276.

## 5. Housing of sows during farrowing: a review on pen design, welfare and productivity

- Baxter, M.R. and Schwaller, C.E., 1983. Space requirement for sows in confinement. In Baxter, S.H., Baxter, M.R. and MacCormack, J.A.D. (eds.) *Farm animal housing and welfare*. Martinus Nijhoff Publisher, the Hague, the Netherlands, pp. 1481-1495.
- Biensen, N.J., Von Borell, E.H. and Ford, S.P., 1996. Effects of space allocation and temperature on periparturient maternal behaviors, steroid concentrations, and piglet growth rates. *Journal of Animal Science* 74: 2641-2648.
- Bonde, M., Rousing, T., Badsberg, J.H. and Sørensen, J.T., 2004. Associations between lying-down behaviour problems and body condition, limb disorders and skin lesions of lactating sows housed in farrowing crates in commercial sow herds. *Livestock Production Science* 87: 179-187.
- Boyle, L.A., Leonard, F.C., Lynch, P.B. and Brophy, P., 2000. Influence of housing system during gestation on the behaviour and welfare of gilts in farrowing crates. *Animal Science* 71: 561-570.
- Burri, M., Wechsler, B., Gygax, L. and Weber, R., 2009. Influence of straw length, sow behaviour and room temperature on the incidence of dangerous situations for piglets in a loose farrowing system. *Applied Animal Behaviour Science* 117: 181-189.
- Chen, C., Gilbert, C.L., Yang, G., Guo, Y., Segonds-Pichon, A., Ma, J., Evans, G., Brenig, B., Sargent, C., Affara, N. and Huang, L., 2008. Maternal infanticide in sows: incidence and behavioural comparisons between savaging and non-savaging sows at parturition. *Applied Animal Behaviour Science* 109: 238-248.
- Cronin, G.M., Dunsmore, B. and Leeson, E., 1998. The effects of farrowing nest size and width on sow and piglet behaviour and piglet survival. *Applied Animal Behaviour Science* 60: 331-345.
- Cronin, G.M., Lefebure, B. and McClintock, S., 2000. A comparison of piglet production and survival in the Werribee Farrowing Pen and conventional farrowing crates at a commercial farm. *Australian Journal of Experimental Agriculture* 40: 17-23.
- Cronin, G.M., Simpson, G.J. and Hemsworth, P.H., 1996. The effects of the gestation and farrowing environments on sow and piglet behaviour and piglet survival and growth in early lactation. *Applied Animal Behaviour Science* 46: 175-192.
- Curtis, S.E., Hurst, R.J., Gonyou, H.W., Jensen, A.H. and Muehling, A.J., 1989. The physical space requirement of the sow. *Journal of Animal Science* 67: 1242-1248.
- Damgaard, B.M., Malmkvist, J., Pedersen, L.J., Jensen, K.H., Thodberg, K., Jorgensen, E. and Juul-Madsen, H.R., 2009. The effects of floor heating on body temperature, water consumption, stress response and immune competence around parturition in loose-housed sows. *Research in Veterinary Science* 86: 136-145.
- Damm, B.I. and Pedersen, L.J., 2000. Eliminative behaviour in preparturient gilts previously kept in pens or stalls. *Acta Agriculturae Scandinavica Section A-Animal Science* 50: 316-320.
- Damm, B.I., Heiskanen, T., Pedersen, L.J., Jorgensen, E. and Forkman, B., 2010. Sow preferences for farrowing under a cover with and without access to straw. *Applied Animal Behaviour Science* 126: 97-104.
- Damm, B.I., Lisborg, L., Vestergaard, K.S. and Vanicek, J., 2003. Nest-building, behavioural disturbances and heart rate in farrowing sows kept in crates and Schmid pens. *Livestock Production Science* 80: 175-187.
- Damm, B.I., Moustsen, V., Jorgensen, E., Pedersen, L.J., Heiskanen, T. and Forkman, B., 2006. Sow preferences for walls to lean against when lying down. *Applied Animal Behaviour Science* 99: 53-63.
- Damm, B.I., Vestergaard, K.S., Schroder-Petersen, D.L. and Ladewig, J., 2000. The effects of branches on prepartum nest building in gilts with access to straw. *Applied Animal Behaviour Science* 69: 113-124.
- EFSA, 2007. Scientific report on the health and welfare aspects of different housing and husbandry systems for adult boars, pregnant, farrowing sows and unweaned piglets. *The EFSA Journal*. 572: 1-107.
- Gustafsson, B., 1983. Effects of sow housing systems in practical pig production. *Transactions of the ASAE*, 26, 1181-1185, 1193.



- Harris, M.J. and Gonyou, H.W., 1998. Increasing available space in a farrowing crate does not facilitate postural changes or maternal responses in gilts. *Applied Animal Behaviour Science* 59: 285-296.
- Harris, M.J. and Gonyou, H.W., 2003. Savaging behaviour in domestic gilts: a study of seven commercial farms. *Canadian Journal of Animal Science* 83: 435-444.
- Hartsock, T. G. and Barczewski, R.A., 1997. Parturition behavior in swine: effects of pen size. *Journal of Animal Science* 75: 2899-2904.
- Herskin, M.S., Jensen, K.H. and Thodberg, K., 1998. Influence of environmental stimuli on maternal behaviour related to bonding, reactivity and crushing of piglets in domestic sows.
- Houbak, B., Thodberg, K., Malmkvist, J. and Pedersen, L.J., 2006. Effect of pen floor heating on piglets' use of heated area 0-120 h postpartum. *Proc. 40<sup>th</sup> Int. Congr. of the ISAE, Bristol, U.K.*, p. 156.
- Hrupka, B.J., Leibbrandt, V.D., Crenshaw, T.D. and Benevenga, N.J., 2000a. Effect of sensory stimuli on huddling behavior of pigs. *Journal of Animal Science* 78: 592-596.
- Hrupka, B.J., Leibbrandt, V.D., Crenshaw, T.D. and Benevenga, N.J., 2000b. The effect of thermal environment and age on neonatal pig behavior. *Journal of Animal Science* 78: 583-591.
- Hunt, K. and Petchey, A.M., 1989. Degree of enclosure preferred by sows around farrowing. *Animal Production* 48: 643.
- Jarvis, S., D'Eath, R.B., Robson, S.K. and Lawrence, A.B., 2006. The effect of confinement during lactation on the hypothalamic-pituitary-adrenal axis and behaviour of primiparous sows. *Physiology & Behavior* 87: 345-352.
- Jarvis, S., Lawrence, A.B., Mclean, K.A., Deans, L.A., Chirnside, J. and Calvert, S.K., 1997. The effect of environment on behavioural activity, ACTH, beta-endorphin and cortisol in pre-farrowing gilts. *Animal Science* 65: 465-472.
- Jarvis, S., Reed, B.T., Lawrence, A.B., Calvert, S.K. and Stevenson, J., 2004. Peri-natal environmental effects on maternal behaviour, pituitary and adrenal activation, and the progress of parturition in the primiparous sow. *Animal Welfare* 13: 171-181.
- Jarvis, S., Van der Vegt, B.J., Lawrence, A.B., Mclean, K.A., Deans, L.A., Chirnside, J. and Calvert, S.K., 2001. The effect of parity and environmental restriction on behavioural and physiological responses of pre-parturient pigs. *Applied Animal Behaviour Science* 71: 203-216.
- Jensen, P., 1986. Observations on the maternal behaviour of free-ranging domestic pigs. *Applied Animal Behaviour Science* 16: 131-142.
- Jensen, P., Vestergaard, K. and Algers, B., 1993. Nestbuilding in Free-Ranging Domestic Sows. *Applied Animal Behaviour Science* 38: 245-255.
- KilBride, A.L., Mendl, M., Statham, P., Held, S., Harris, M., Cooper, S. and Green, L.E., 2012. A cohort study of preweaning piglet mortality and farrowing accommodation on 112 commercial pig farms in England. *Preventive Veterinary Medicine* 104: 281-291.
- Lawrence, A.B., Petherick, J.C., Mclean, K., Gilbert, C.L., Chapman, C. and Russell, J.A., 1992. Naloxone prevents interruption of parturition and increases plasma oxytocin following environmental disturbance in parturient sows. *Physiology & Behavior* 52: 917-923.
- Lawrence, A.B., Petherick, J.C., Mclean, K.A., Deans, L.A., Chirnside, J., Vaughan, A., Clutton, E. and Terlouw, E.M.C., 1994. The effect of environment on behavior, plasma-cortisol and prolactin in parturient sows. *Applied Animal Behaviour Science* 39: 313-330.
- Leeb, B., Leeb, C., Troxler, J. and Schuh, M., 2001. Skin lesions and callosities in group-housed pregnant sows: Animal-related welfare indicators. *Acta Agriculturae Scandinavica Section A-Animal Science*, pp. 82-87.

## 5. Housing of sows during farrowing: a review on pen design, welfare and productivity

- Malmkvist, J., Damgaard, B.M., Pedersen, L.J., Jorgensen, E., Thodberg, K., Chaloupkova, H. and Bruckmaier, R.M., 2009. Effects of thermal environment on hypothalamic-pituitary-adrenal axis hormones, oxytocin, and behavioral activity in periparturient sows. *Journal of Animal Science* 87: 2796-2805.
- Malmkvist, J., Pedersen, L.J., Damgaard, B.M., Thodberg, K., Jorgensen, E. and Labouriau, R., 2006. Does floor heating around parturition affect the vitality of piglets born to loose housed sows? *Applied Animal Behaviour Science* 99: 88-105.
- Malmkvist, J., Pedersen, L.P., Jensen, T. and Jørgensen, E., 2012. Influence of thermal environment on sows around farrowing and during the lactation period. *Journal of Animal Science* 90: 3186-3199.
- Marchant Forde, J.N., 2002. Piglet- and stockperson-directed sow aggression after farrowing and the relationship with a pre-farrowing, human approach test. *Applied Animal Behaviour Science* 75: 115-132.
- Marchant, J.N. and Broom, D.M., 1996. Effects of dry sow housing conditions on muscle weight and bone strength. *Animal Science* 62: 105-113.
- Marchant, J.N., Broom, D.M. and Corning, S., 2001. The influence of sow behaviour on piglet mortality due to crushing in an open farrowing system. *Animal Science* 72: 19-28.
- Marchant, J.N., Rudd, A.R. and Broom, D.M., 1997. The effects of housing on heart rate of gestating sows during specific behaviours. *Applied Animal Behaviour Science* 55: 67-78.
- McGlone, J.J., Vines, B., Rudine, A.C. and DuBois, P., 2004. The physical size of gestating sows. *Journal of Animal Science* 82: 2421-2427.
- Moustsen, V.A. and Poulsen, H.L., 2004b. Sammenligning af produktionsresultater opnået i henholdsvis en traditionel kassesti og en sti til løsgående farende og diegivende søer. (Comparison of production results in traditional crates and pens for loose farrowing and lactating sows). Meddelelse 679. Videncenter For Svineproduktion. Available at: [http://vsp.lf.dk/Publikationer/Kilder/lu\\_medd/2004/679.aspx](http://vsp.lf.dk/Publikationer/Kilder/lu_medd/2004/679.aspx).
- Moustsen, V.A. and Duus, K.L., 2006. Søers 'rejse og lægge sig' bevægelse i forskelligearestier' (The laying down and getting up movements in sows in different farrowing pens). Meddelelse 733, Landsudvalget for Svin. Available at: [http://vsp.lf.dk/Publikationer/Kilder/lu\\_medd/2006/733.aspx](http://vsp.lf.dk/Publikationer/Kilder/lu_medd/2006/733.aspx).
- Moustsen, V.A. and Poulsen, H.L., 2004a. 'Pattegrises dimensioner'. (The dimensions of piglets). Notat 0432. Videncenter For Svineproduktion. Available at: <http://vsp.lf.dk/Publikationer/Kilder/notater/2004/0432.aspx>.
- Moustsen, V.A., 2006. Skrå liggevægge til løsgående diegivende søer. (Sloping walls to loosed housed lactating sows). Meddelelse 755, Videncenter For Svineproduktion. Available at: [http://vsp.lf.dk/Publikationer/Kilder/lu\\_medd/2006/755.aspx](http://vsp.lf.dk/Publikationer/Kilder/lu_medd/2006/755.aspx).
- Moustsen, V.A., Poulsen, H.L. and Nielsen, M.B.F., 2004. 'Krydsnings søers dimensioner' (The dimensions of cross bred sows). Medd. 649. Videncenter For Svineproduktion. Available at: [http://vsp.lf.dk/Publikationer/Kilder/lu\\_medd/2004/649.aspx](http://vsp.lf.dk/Publikationer/Kilder/lu_medd/2004/649.aspx).
- O'Reilly, K.M., Harris, M.J., Mendl, M., Held, S., Moinard, C., Statham, P., Marchant-Forde, J. and Green, L.E., 2006. Factors associated with preweaning mortality on commercial pig farms in England and Wales. *The Veterinary Record* 159: 193-196.
- Oliviero, C., Heinonen, M., Valros, A. and Peltoniemi, O., 2010. Environmental and sow-related factors affecting the duration of farrowing. *Animal Reproduction Science* 119: 85-91.
- Oliviero, C., Heinonen, M., Valros, A., Hälli, O. and Peltoniemi, O.A.T., 2008. Effect of the environment on the physiology of the sow during late pregnancy, farrowing and early lactation. *Animal Reproduction Science* 105: 365-377.
- Pajor, E.A., Kramer, D.L. and Fraser, D., 2000. Regulation of contact with offspring by domestic sows: Temporal patterns and individual variation. *Ethology* 106: 37-51.



- Pedersen, L.J., Damm, B.I., Marchant-Forde, J.N. and Jensen, K.H., 2003. Effects of feed-back from the nest on maternal responsiveness and postural changes in primiparous sows during the first 24 h after farrowing onset. *Applied Animal Behaviour Science* 83: 109-124.
- Pedersen, L.J. and Jensen, T., 2008. Effects of late introduction of sows to two farrowing environments on the progress of farrowing and maternal behavior. *Journal of Animal Science* 86: 2730-2737.
- Pedersen, L.J., Berg, P., Jørgensen, E., Bonde, M., Herskin, M.S., Knage-Rasmussen, K.M., Kongsted, A.G., Lauridsen, C., Oksbjerg, N., Poulsen, H.D., Sorensen, D., Su, G., Sorensen, M.T., Theil, P.K., Thodberg, K. and Jensen, K.H., 2010. Pattegrisedødelighed i DK: Muligheder for reduktion af pattegrisedødeligheden i Danmark. (Piglet mortality in Denmark: possibilities for reducing neonatal piglet mortality in Denmark). DJF Rapport – Husdyrbrug, vol. 86, Aarhus Universitet, Det Jordbrugsvidenskabelige Fakultet, Denmark.
- Pedersen, L.J., Berg, P., Jørgensen, G. and Andersen, I.L., 2011. Neonatal piglet traits of importance for survival in crates and indoor pens. *Journal of Animal Science* 89: 1207-1218.
- Pedersen, L.J., Jørgensen, E., Heiskanen, T. and Damm, B.I., 2006. Early piglet mortality in loose-housed sows related to sow and piglet behaviour and to the progress of parturition. *Applied Animal Behaviour Science* 96: 215-232.
- Pedersen, L.J., Malmkvist, J. and Jørgensen, E., 2007a. The use of a heated floor area by sows and piglets in farrowing pens. *Applied Animal Behaviour Science* 103: 1-11.
- Pedersen, L.J., Malmkvist, J. and Jørgensen, E., 2007b. The use of a heated floor area by sows and piglets in farrowing pens. *Applied Animal Behaviour Science* 103: 1-11.
- Pedersen, L.J., Malmkvist, J., Jensen, T., Jørgensen, E., 2013. Avoiding hypothermia in neonatal piglets: the effect of duration of floor heating at different room temperatures. *Journal of Animal Science* 91:425-432.
- Pedersen, O.G. and Ingwersen, J., 1981. Afprøvning af 4 forskellige farestityper. (Field tests of four different farrowing pens). *Dansk svineproduktion, Medd. Nr. 30*. Available at: [http://vsp.lf.dk/Publikationer/Kilder/lu\\_medd/medd/30.aspx](http://vsp.lf.dk/Publikationer/Kilder/lu_medd/medd/30.aspx).
- Phillips, P.A., Fraser, D. and Pawluczuk, B., 2000. Floor temperature preference of sows at farrowing. *Applied Animal Behaviour Science* 67: 59-65.
- Phillips, P.A., Fraser, D. and Thompson, B.K., 1991. Preference by sows for a partially enclosed farrowing crate. *Applied Animal Behaviour Science* 32: 35-43.
- Prunier, A., De Braganga, M.M. and Le Dividich, J., 1997. Influence of high ambient temperature on performance of reproductive sows. *Livestock Production Science* 52: 123-133.
- Quiniou, N. and Noblet, J., 1999. Influence of high ambient temperatures on performance of multiparous lactating sows. *Journal of Animal Science* 77: 2124-2134.
- Roehe, R. and Kalm, E., 2000. Estimation of genetic and environmental risk factors associated with pre-weaning mortality in piglets using generalized linear mixed models. *Animal Science* 70: 227-240.
- Sancha, S.E and Arey, D.S., 1995. Sows preference for roofed farrowing areas. *Farm Building Progress* 117: 36-39.
- Schmid, H., 1992. Arttypische Strukturierung der Abferkelbucht. In: *Aktuelle Arbeiten zur artgemässen Tierhaltung 1991, KTBL-Schrift 351*. KTBL, Darmstadt, Germany, pp. 27-36.
- Stolba, A. and Wood-Gush, D.G.M., 1984. The identification of behavioral key features and their incorporation into a housing design for pigs. *Annales de Recherches Veterinaires* 15: 287-298.
- Stolba, A. and Wood-Gush, D.G.M., 1989. The behaviour of piglets in a semi-natural environment. *Animal Production* 48: 419-425.
- Su, G., Lund, M.S. and Sorensen, D., 2007. Selection for litter size at day five to improve litter size at weaning and piglet survival rate. *Journal of Animal Science* 85: 1385-1392.

## 5. Housing of sows during farrowing: a review on pen design, welfare and productivity

- Taylor, L., Friend, T. and Smith, L.A., 1988. Effect of housing on in situ postures of gestating gilts. *Applied Animal Behaviour Science* 19: 265-272.
- Thodberg, K., Jensen, K.H., Herskin, M.S. and Jorgensen, E., 1999. Influence of environmental stimuli on nest building and farrowing behaviour in domestic sows. *Applied Animal Behaviour Science* 63: 131-144.
- Thodberg, K., Jørgensen, E., Olsson, A.C., Houbak, B. and Pedersen, L.J., 2008. The relationship between pre-pubertal inactivity and maternal ability in loose-housed sows. *Proceedings of the 42<sup>nd</sup> International Congress of the ISAE, Dublin, Ireland*, p. 79.
- Troxler, J. and Weber, R., 1989, Die Anwendung ethologischer Erkenntnisse bei der Prüfung von Stalleinrichtungen für Schweine. In: *Aktuelle Arbeiten zur artgemässen Tierhaltung 1988*, KTBL-Schrift 336, KTBL, Darmstadt, Germany, pp. 142-149.
- Tuchscherer, M., Puppe, B., Tuchscherer, A. and Tiemann, U., 2000. Early identification of neonates at risk: Traits of newborn piglets with respect to survival. *Theriogenology* 54: 371-388.
- Weber, R. and Troxler, J., 1988, Die Bedeutung der Zeitdauer der Geburt in verschiedenen Abferkelbuchten zur Beurteilung auf Tiergerechtigkeit. In: *Aktuelle Arbeiten zur artgemässen Tierhaltung 1987*, KTBL-Schrift 323. KTBL, Darmstadt, Germany, pp. 172-184.
- Weber, R., 1984, Entwicklung einer Abferkelbucht nach ethologischen und verfahrenstechnischen Gesichtspunkten. In: *Aktuelle Arbeiten zur artgemässen Tierhaltung 1983*, KTBL-Schrift 299. KTBL, Darmstadt, Germany, pp. 153-165.
- Weber, R., Keil, N.M., Fehr, M. and Horat, R., 2007. Piglet mortality on farms using farrowing systems with or without crates. *Animal Welfare* 16: 277-279.
- Wischner, D., Kemper, N and Krieter, J., 2009a. Nest-building behaviour in sows and consequences for pig husbandry. *Livestock Science* 124: 1-8.
- Wischner, D., Kemper, N., Stamer, E., Hellbruegge, B., Presuhn, U. and Krieter, J., 2009b. Characterisation of sows' postures and posture changes with regard to crushing piglets. *Applied Animal Behaviour Science* 119: 49-55.
- Wülbers-Mindermann, M., Algers, B., Berg, C., Lundeheim, N. and Sigvardsson, J., 2002. Primiparous and multiparous maternal ability in sows in relation to indoor and outdoor farrowing systems. *Livestock Production Science* 73: 285-297.



## **Part 3**

### **Feed, water, bedding and waste management**



## **6. The impact of feeding and drinking management, and bedding and waste management, on animal health, welfare and performance**

*I. Ekesbo*

*Department of Animal Environment and Health, Swedish University of Agricultural Sciences, P.O. Box 234, 53223 Skara, Sweden; [ingvar.ekesbo@slu.se](mailto:ingvar.ekesbo@slu.se)*

### **Abstract**

This paper describes for the most common farm animal species, in three sections, their basic biological needs related to eating, drinking, flooring, bedding and waste management, and the health hazards if these needs are not met. Such health disorders will always involve risks of impaired performance. A short description is given of the prevalence and clinical symptoms of pathogenic risk agents which can affect farm animals via feed, water, bedding or wastes, also some which, via animals or animal products, are health risk factors for humans. At the end of each section conclusions are presented.

**Keywords:** animal hygiene, bedding, behaviour, drinking, health, management, performance, waste, welfare

### **6.1 Introduction**

The equilibrium between farm animal health and disease can be altered by management and environmental factors not adapted to the animals' basic biological needs. Knowledge of these needs, as well as knowledge of health risk factors related to feed, water, flooring, bedding and waste management, are necessary for good and responsible farm animal husbandry. Knowledge of natural behaviour helps in understanding the behavioural needs of farm animals and thus informs changes to housing and management to better meet these needs.

### **6.2 The impact of feeding and drinking management on animal health, welfare and performance**

#### **6.2.1 Farm animal feeding and drinking behaviour and biological requirements**

##### *Horses*

Horses graze through collecting the grass with their prehensile upper lip, and biting it off the near the ground with the front teeth. When grazing they move slowly forward, one leg at a time, and usually only take about two mouthfuls before they take a step further forward. They avoid grazing on sites with horse-droppings (Ekesbo, 2011). On the other hand, they graze the grass around cow-dung that is rejected by cattle.

## I. Ekesbo

The young foal does not graze very efficiently until it is several weeks old. By about the end of the first week of life, however, the foal has begun to nibble the herbage in association with its dam. The essential feeding habits of the mares are learned by young foals (Fraser, 2010).

According to dietary profiles, compiled from world literature, the dietary botanical composition of the average horse in the wild, for all seasons, consists of 69% grass, 15% forb (herbs) and 16% browse (Alcock, 1992). They like to take leaves and minor twigs, and sometimes bark, from trees. Sometimes horses in pastures with trees start biting the trunks and chewing bark and wood, often thereby totally debarking the lower parts of the trees.

Horses eat in total for 12 hours or more both during the daytime and at night. Therefore, when kept indoors they must have some forage for the night. Grazing and browsing bouts are interrupted by other behaviours. In housed horses, given feed *ad libitum*, 17 feeding bouts were reported during 24 hours (Ekesbo, 2011).

A medium-sized horse might need to drink up to about 40 litres of water per day. Unlike other animals horses do not drink often, many horses not more than twice per day, except at high temperatures. Horses drink with large quantities in each gulp.

### *Cattle*

Cattle graze herbage by collecting it into the mouth and compressing it against the upper palate with the tongue and lower incisors. The herbage is then severed from the plants by jerking the head upwards. This is repeated many times a minute, typically 30-70, and the animal moves its head from side to side as it slowly walks forward. When cattle eat roughage, e.g. hay or silage, the tongue is used to a greater extent to manipulate particles into the buccal cavity. When grazing, cattle always have one foreleg before the other. They cannot graze normally with both forelegs together. Cattle never graze on spots contaminated by manure, behaviour that to a certain extent implies protection against transmission of infection. Such uneaten patches are characterized by abundant green grass, and remain untouched even on hard-grazed land. In the same way, cattle try to avoid areas top-dressed with liquid manure. On such pastures cows are seen roaming about trying to find uncontaminated areas; this limits their feed intake. However, if cows are put on pasture a few days after it has been top-dressed by urine they do not hesitate to graze. Cattle kept on natural pastures with different types of vegetation show notably varying feeding behaviour. They might, after having grazed an area of clover, change to an area with a quite different flora, and whenever an opportunity arises they combine their diet with sprigs from deciduous trees such as aspen, oak or birch (Ekesbo, 2011).

Rumination is performed in bouts of about 45 minutes and thus accounts for a substantial part of the day, six to eight hours. Cattle ruminate most often when lying, but rumination also occurs in the standing position (Ekesbo, 2011).

Within two or three weeks the young calf will already start eating hay or, if on pasture, pick some grass. According to dietary profiles compiled from world literature the cattle diet, by botanical

## 6. The impact of feeding, drinking, bedding and waste management

composition (over all seasons), consists of 72% grass, 15% forb (herbs) and 13% browse for adult cattle in the wild (Alcock, 1992).

Cattle, by nature, have a need to search for feed and use about 12 hours actively looking for food. This behavioural need exists even if a cow has its nutritional requirements satisfied by a very concentrated feed in, for example, three hours. Therefore, cattle kept indoors, or outdoors without access to pasture, must always have access to roughage (Ekesbo, 2011).

Cattle drink by lowering the muzzle into the water, but keep their nostrils above the water surface and suck the water into the mouth. Water requirement varies with age and milk yield. Adult cattle require about 50 litres water daily, lactating dairy cows 100 to 150 litres. High temperatures increase the need for water. For a cow producing 35 litres milk per day the requirement is about 100 litres of water during the winter, but 115 litres during the summer. A cow milking 50 litres per day needs 150 litres. If cattle have a choice they prefer drinking water with a temperature over 15 °C. The amount of water consumed per minute is higher when given from an open water surface than from a water bowl (Murphy, 1992).

New-born calves suckle their dam five to ten times per day. It is usually difficult to get new-born calves to drink from a bucket. This can often be remedied by slipping two fingers into the calf's mouth, thereby triggering the sucking reflex. When a calf drinks directly from a bucket its head position is different from when sucking from the udder; and this is considered to counteract effective closure of the reticular groove. This might result in milk getting into the rumen. Eager drinking from the bucket might also result in some milk being aspirated into the respiratory tract. Drinking from a bucket does not satisfy their motivation for sucking behaviour, which can result in them trying to suck on different objects, i.e. other calves or pen fittings in their surroundings. For these reasons buckets with an artificial teat are preferable for young calves. The calf requires colostrum from its mother or, if this is not possible, first-day colostrum from another cow, during the three first days of life. It requires milk or milk substitute until at least six weeks of age. Thereafter the milk can be replaced by water and special feed. Calves must have free access to high-class hay from the beginning of their second week of life (Ekesbo, 2011).

### *Sheep*

Sheep grasp grass between the lower teeth and the dental pad, and then tear, when the head is moved posteriorly with a sudden jerking movement. The head may swing laterally and more food is grasped, while a fore or hind leg takes one step forward. When eating browse, the sheep can strip the branch of leaves, break a twig and chew it, or remove discrete leaves. They are very selective grazers, choosing not only specific plants but also preferring leaves and blades over stems. Their divided upper lip, the philtrum, facilitates the removal of small plant parts. During their first week of life lambs already nibble on vegetation, and this activity becomes more common with age. Rumination occurs for about eight hours per day. Rumination occurs both in the lying and standing position, but requires calm and peace and the sheep should not be disturbed in any way. Sheep are not able to ruminate during transport (Ekesbo, 2011).



## I. Ekesbo

According to dietary profiles compiled from world literature the average dietary botanical composition, for all seasons, consists of 50% grass, 30% forb (herbs) and 20% browse for sheep in the wild (Alcock, 1992).

Sheep, like cattle, by nature have a need to search for feed, and can spend up to 12 hours actively searching feed. However, they devote about eight hours per day in efficient grazing. This food seeking behaviour is still shown even when the sheep may have its nutritional requirements satisfied within three hours, in the form of a concentrated feed ration. In order to fulfil this behavioural need sheep, when kept indoors, should always therefore have access to roughage, preferably straw or hay (Ekesbo, 2011).

The water requirement of sheep varies with age and milk yield. Sheep on pasture might need to drink more than once per day, but they can spend several days without water. On the other hand adult ewes given dry feed may require up to 20 litres of water per day, especially ewes that suckle (Ekesbo, 2011).

### *Goats*

The upper lip of the goat is more mobile than that of the sheep, allowing the goat to be more selective, and to be able to select preferred plant parts with relative ease.

Goats prefer a mixed diet and they can very efficiently digest coarse roughage, such as the leaves of many trees and shrubs. They select their diets from a greater range of forage sources than sheep. They obtain their food by browsing more than by grazing. As agile climbers, goats will even climb into trees to obtain browse (Dwyer, 2009). Goats prefer hay to silage (Jørgensen *et al.*, 2007).

According to dietary profiles compiled from world literature the average dietary botanical composition for goats in the wild, for all seasons, consists of 29% grass, 12% forb (herbs) and 59% browse (Alcock, 1992). Like cattle and sheep, goats avoid grass contaminated by conspecifics' manure.

Goats need to drink almost daily, although due to their browse diet they may be adapted to coping with periods without water better than other farmed animals (Ekesbo, 2011).

### *Pigs*

Pigs in the wild are omnivorous, eating grass, roots, fruit, berries, seeds, earthworms, frogs, small rodents and other material of plant and animal origin. Most food seeking involves rooting in the ground, but grazing and browsing also occur. The snout of the pig is especially adapted for rooting. With the upper part of the snout adult pigs can move stones and suchlike heavy objects in order to get access to roots, seeds and similar feed. The snout is tapered, and the nasal disc is rigid enough to withstand considerable force while it is richly supplied with widely spaced, short vibrissae, connected to sensory receptors. These olfactory abilities enable foraging and rooting to be combined with smelling and chewing of edible objects. Pigs have a strong preference for

## 6. The impact of feeding, drinking, bedding and waste management

rooting, even when satiated. Thus rooting may constitute a basic need for pigs and it has been shown that ringed sows show evidence of frustration (Ekesbo, 2011).

Pigs are susceptible to a lack of water. The water requirements for domestic pigs vary with weight and age. Pigs weighing 21-46 kg require, at 20 °C, about 0.12 litres of water per kg body weight, and at 52-66 kg about 0.09 litres per kg body weight. The requirements increase by up to 70% at 30 °C. Adult sows may require up to 25 litres water per day at high ambient temperatures (Ekesbo, 2011).

### *Rabbits*

Field studies of wild rabbits indicate that they are selective feeders with a wide food range. Unlike the grazing horse or cow, which eats the entire plant, the rabbit selects the most nutritious part of the plant, favouring young, succulent plants over mature, coarse growth. Rabbits chew their food thoroughly. Rabbits ingest coarse fibre only to stimulate gut motility and rapidly excrete it, unlike horses, which carry fibre for up to three days. The rabbit caecum is the largest of all animals, relative to size, with 10 times the capacity of the stomach and it contains 40% of the intestinal content. Pellets of soft caecal contents (caecotrophs) are periodically expelled from the anus and re-ingested as a source of nutrients. This digestive strategy utilizes bacterial fermentation to synthesize nutrients, and avoids the need to store large volumes of food in the digestive tract. Vegetation can be efficiently digested below ground without the need to spend long periods grazing while exposed to predators (Ekesbo, 2011).

Compared with other animals, rabbits have a high water intake. A rabbit's average daily water intake is 50 to 150 ml/kg of body weight; a 2 kg rabbit drinks about as much water daily as does a 10 kg dog (Ekesbo, 2011).

### *Domestic fowl*

Chickens' food-seeking behaviour consists in pecking with the beak and scraping with their feet and claws to find feed. As omnivores, domestic fowls kept outdoors eat seeds, grubs, worms and insects. They search and obtain their food by scratching and pecking the ground and alternate feeding and drinking throughout the day. Chickens drink often, and in small quantities, and therefore a permanent water resource is a necessity. An adult chicken requires 150-200 ml water per day at normal outdoor temperature. Poultry drink by putting their beak end just under the water surface, then scooping up water into their beaks, and then raising their heads so that the water runs down the oesophagus. In most commercial herds hens are given nipple drinkers instead of troughs or cups. Some nipple drinkers require the birds to drink in an unnatural way, or do not give enough water flow (Ekesbo, 2011).

### *Turkeys*

Turkeys possess the basic avian pattern of feeding. Swallowing is accomplished without the necessity of raising the head, although some adults may lift the head frequently while gulping large quantities of mash. Scratching behaviour is an important component of foraging for food

## I. Ekesbo

in wild turkeys. When feeding on acorns covered with leaves, wild turkeys may dig up vast areas. In domestic turkeys scratching behaviour is rarely observed on the range, or in litter provided in pens, and seems to depend upon the rearing conditions (Ekesbo, 2011).

Wild turkeys are omnivorous, feeding on plants, seeds, insects and worms. Shrubs are the most important food throughout the year (42%), followed by grasses (31%), and tree and forb species, together 28% (Morales *et al.*, 1997).

Drinking in turkeys is accomplished differently from feeding, with the turkey dipping its beak into the water to the level of the nares and making several rapid partial closures of the beak. It then raises its head, extends the beak upward and repeats several rapid closures of the beak. The latter pattern suggests some degree of active swallowing in addition to flow by gravity to the oesophagus (Ekesbo, 2011).

### **6.2.2 The feeding plan**

Different types of disorders might occur if feed or feeding systems do not meet biological needs. Space does not permit a description of such disorders and their causes in the different species. A well balanced diet is the best guarantee to avoid such disorders irrespective of species.

### **6.2.3 Pathogenic agents which can occur in farm animals and which are health risk factors for humans**

*Escherichia coli*

Many serogroups of *E. coli* have the potential to cause illness in humans. Among the predominant serogroups in clinical cases is O157, historically the most important serotype in clinical infection in humans in many parts of the world. Infection by this is one of the more serious forms of food-borne illness as it can lead to serious, sometimes fatal, complications. Acute symptoms are generally self-limiting and include abdominal pain, watery diarrhoea which may become bloody, and sometimes vomiting. Fever is either mild or absent. Additional complications may occur, including haemolytic uraemic syndrome (HUS). Around 5% of infections result in HUS, and mortality from HUS is around 10% (Rhoades *et al.*, 2009).

Cattle have been identified as the main reservoir of *E. coli* O157 infections for humans, and the traditional route of transmission from cattle to man is via contaminated meat. Cattle are asymptomatic carriers and the infection causes no production loss. Young cattle between 2-18 months of age are at highest risk of excreting *E. coli* O157 through faeces or saliva. Shedding by the individual animal is intermittent, probably due to re-circulation of the pathogens between animals or the environment, and recent simulation models have suggested that the majority of transmission occurs through the environment. The proportion of infections acquired by direct contact with cattle or from contaminated environments such as fields or water courses is increasing (Ellis-Iversen *et al.*, 2008).

## 6. The impact of feeding, drinking, bedding and waste management

### Salmonella

Salmonella is one of the most common food-borne diseases in man and it is widespread in many countries. Most serotypes of *Salmonella enterica* cause self-limiting gastroenteritis characterized by diarrhoea, stomach cramps and sometimes vomiting and fever (Rhoades *et al.*, 2009). Eggs, poultry and pork are the most-important sources for human Salmonellosis. Animals are mostly disease carriers without showing symptoms.

Feed companies in Europe purchase feed materials and grain of different hygienic qualities, from domestic, European and overseas producers. *Salmonella* is often introduced into feed mills and pig holdings via feed materials (Binter *et al.*, 2011; Plym-Forshell and Svedberg, 1981).

Sampling of dust and sweepings from control points along the feed plant production line is an efficient strategy to gain an indication of *Salmonella* contamination (Binter *et al.*, 2011). Systematic use of such controls (Plym-Forshell and Svedberg, 1981) has been an important part of the programme to rid Swedish farm animal herds of *Salmonella*. Sweden already began to control *Salmonella* in the 1950s, and since 1961 the country has had a separate *Salmonella* law. This law provides that foods contaminated with *salmonella* may not be sold. *Salmonella* control is based on control of the whole chain: from the production of fodder, the keeping of animals, the carcasses of the slaughtered animals, and the production of meat products, to the handling of these in the shops.

EFSA (The European Food Safety Authority) has reported the following finds of *Salmonella* in feed in the EU: for raw materials: fishmeal 1.9%, meat and bone meal 2.3%, cereals 0.3%, oil seeds 2.5%. For compound feedstuffs 0-9.4%. Variations in different member states for cattle feed ranged from 0% to 9.4%, for pig feed from 0% to 3.3%, and for poultry feed from 0% to 5.3%. However, *Salmonella enteritidis* and *Salmonella typhimurium* were found relatively seldom, the former in four and the latter in three member states, all found in compound feed (EFSA, 2008).

A study in the US indicates that feed and feed trucks to and from the farms could be a source of *Salmonella* contamination for swine (Fedorka-Cray *et al.*, 1997).

EFSA conducted baseline studies in all member countries in 2004-2007 regarding *Salmonella* among laying hens, chickens and pigs. These studies were unique in that the samples were collected in the same way in all countries so that the results are comparable. Results of the study among sows and slaughter pigs indicated that the average prevalence of *Salmonella* in the EU was 29% for sow herds and 10.3% for slaughter pig herds. Finland, Norway and Sweden were exceptions with 0-1.5%. Studies regarding laying hens and broiler chickens in most EU countries show that an average of 31% of laying flocks in these countries have *Salmonella*. Sweden was the only country where all investigated flocks were free from *Salmonella*. However, Finland and Denmark also had low figures, only 0.4 and 2.7% respectively of the poultry laying flocks were infected with *Salmonella*. For broiler chickens, the average EU prevalence was just under 24% (EFSA, 2008).

## I. Ekesbo

There are several studies indicating a high prevalence of *Salmonella* in US pig herds. Davies and Morrow (1997) reported at least one infected faecal sample in 83% of the studied farms, Bahnson *et al.* (2006) at least one sample type in every studied herd, and the USDA (2009) at least one positive sample in 52.6% of investigated sites.

### Listeria

*Listeria monocytogenes* poses an important health risk for humans, and most reported outbreaks are attributable to the consumption of contaminated products of animal origin. In adult humans meningitis is the most commonly recognized clinical manifestation of listeriosis; the bacterium can also cause endocarditis, septicemia, and skin lesions. Even though the number of clinical cases are far fewer than for the *Salmonella* cases, about 2 per cent of the *Salmonella* cases, the number of deaths are about the same as for *Salmonella*.

Listeriosis occurs sporadically in cattle, sheep, and goats and can also occur in pigs, dogs, cats, some wild animals, and humans. Various strains of the organism have been isolated from clinically infected and clinically normal cows on dairy farms, emphasizing the potential role of dairy farms in its transmission. A comprehensive study in the US showed that the prevalence of *Listeria monocytogenes* was 13% in composite milk samples, 19% in udder swab samples, 43% in faecal samples, 66% in water trough samples, 65% in feed bunk samples, 55% in bedding samples, and 30% in silage samples. Maintaining cleanliness of water troughs and feed bunks is likely to reduce the risk of exposure of dairy cattle to *Listeria* (Mohammed *et al.*, 2009).

The incidence of this disease is increasing worldwide. It is notable for its ability to grow at refrigeration temperatures, unlike most other enteric pathogens. Infection can result in a spectrum of clinical conditions, including septicemia, meningitis, meningoencephalitis, abortion, and in some instances, death (Rhoades *et al.*, 2009).

### Prions

BSE in cattle, scrapie in sheep, and similar diseases such as Creutzfeldt-Jakob disease and kuru in humans, are categorized as transmissible spongiform encephalopathies. The brain tissue of organisms with the disease becomes pitted with holes in a sponge-like pattern. The most common symptoms in cattle are nervousness, sensitive to touching, sensitive to light and, later, disturbances in locomotion. The cause of these diseases is attributed to an unusual infectious agent, a prion. As prions replicate – by converting normal forms of protein into a copy of the prion's abnormal shape – they accumulate within nerve cells, causing neurodegeneration. The onset of the disease in man is usually characterized by vague psychiatric or behavioural changes, which are followed within weeks or months by a progressive dementia that is often accompanied by abnormal vision and involuntary movements. The disease is usually fatal within a year of symptom onset (e.g. Heim *et al.*, 1997; Henry and Knight, 2002).

From 1986 to 2008 nearly 185,000 cases of BSE were confirmed in the United Kingdom and all European countries were hit. Sweden banned feeding ruminants with bone and meat-meal for ethical reasons in 1985. It was for a long period the only country with no cases. However, there

## 6. The impact of feeding, drinking, bedding and waste management

was one case found in 2006, which was a cow that had been imported from another country several years earlier.

Most epidemiological studies suggest that the feedborne source related to meat and bone-meal is the only substantiated route of infection, while it is not possible to exclude maternal transmission, or milk replacers as a source of some infections (Ducrot *et al.*, 2008).

### 6.2.4 Feed and feeding hygiene, water hygiene, pasture hygiene

#### *Feed, feeding and water hygiene*

Cereal grains are commonly preserved by drying. Hot-air drying is an energy and cost-intensive method. With increasing energy costs, alternative low energy input storage systems are used. One such method is crimping and packing moist grain in airtight disposable plastic tubes, a storage method that preserves feed grain through the activity of microorganisms, mainly lactic acid bacteria. Hygienic problems can arise when the moisture content is too low, sustaining only a weak fermentation process. Preservation of moist crimped cereal grain is made feasible through fermentation by lactic acid bacteria. However, climatic variations make it difficult to harvest at suitable moisture contents (0.30-0.45 g/g) to support optimal fermentation under practical conditions. Studies indicate that the addition of starter culture organisms might reduce the risks of such problems (Olstorpe *et al.*, 2010).

Meal as feed is often transported via mechanical conveyors of various types. Transport systems must be regularly controlled and cleaned in order to prohibit enrichment of bacteria or fungi in parts of it, especially angles or nooks or by condensation.

Live bovines may carry pathogens in their gastro-intestinal tract, which are then excreted in the faeces. Three of these are of particular importance for bovine feed and feeding hygiene, namely *E. coli*, *Salmonella* and *Listeria monocytogenes*.

*Clostridium botulinum*, the causative agent of botulism, the source of the most potent poisons known. In farm animals botulism occurs in cattle, sheep and horses. Horses have been poisoned by botulinum toxin, which was formed in baled silage. Botulism in cattle and sheep has been associated with the use of poultry litter as feed (Payne *et al.*, 2011).

The complex diet of ruminants, consisting of forages, concentrates, and preserved feeds, can be a source of very diverse mycotoxins that contaminate individual feed components. A number of mycotoxins are successfully inactivated by the rumen flora, whereas others pass through the rumen unchanged or are converted into metabolites that retain biological activity. Hence, the barrier function of the rumen largely determines the susceptibility of dairy cows, and other ruminant species, towards individual mycotoxins. An impairment of this barrier function due to disease, or the direct antimicrobial effect of certain mycotoxins, may increase absorption rates. The rate of absorption determines not only the internal dose and risk for adverse health effects, but also the excretion of mycotoxins and their biologically active metabolites into milk. (e.g. Fink-Gremmels, 2008).

## I. Ekesbo

Copper intoxication in sheep has been associated with the use of poultry litter as feed (Christodoulopoulos and Roubies, 2007).

### *Pasture hygiene, outdoor water hygiene*

Pastures are usually not fertilized with solid manure if the field has not been ploughed up. However, liquid manure is sometimes spread on pasture land. In order to avoid hygienic problems, fields intended for pasture or for harvesting silage should not be fertilized with liquid manure because of the risks of transmission of infections and other health hazards.

Residues of the manure might be enclosed within green plant material and obstruct the homogeneous acidification of the silage. The same might happen if the green plant material is mixed up with soil, e.g. by muddy tractor wheels in bunker silos. The parts of the silage with such residues do not achieve the intended low pH of 4 or less, and this might facilitate bacterial and fungal growth in the silage which, in turn can lead to serious disorders of the digestive system in ruminants. If the green plant material is gathered into plastic bales without any acidification this risk is even greater. The risk of transmission of pathogens, e.g. *Salmonella* or *E. coli*, via the liquid manure should also not be underestimated (FAO, 1985).

Using liquid manure or sewage sludge as fertilizer on pastures involves risks of transmission to cattle of both bacterial pathogens, e.g. *Salmonella*, and parasites, e.g. gastro-intestinal parasites. There is also another reason to avoid this, namely that cows never graze around spots with cow dung, so called 'rejects', even if the pasture is very poor. Spreading liquid manure on a pasture thus might cause unphysiological stress in grazing cattle. Spreading urine, on the other hand, does not appear to affect the animals, provided that there has been a period of a week between the spreading and the grazing.

Until the 1970s farm animals in most herds were kept outdoors, in the cool temperate zones of the world. Nowadays the majority of swine and poultry are kept indoors the year round. Large dairy herds are also kept indoors the year round. However, in a few countries, e.g. Sweden, the animal welfare law provides that dairy cattle shall be kept on pasture in summer. There are good reasons for this, as several scientific studies have shown that dairy cows kept on pasture are healthier during the grazing period than animals kept indoors during that time (e.g. Bendixen *et al.*, 1986; Bradley and Green, 2001; Ekesbo, 1966).

Repeated use of a pasture year after year risks spreading of infection via the soil or vegetation-surviving parasites. Examples include gastrointestinal parasites in cattle and sheep and lung worm in pigs. Pasture rotation in order to avoid the risks of contamination by surviving parasites or their eggs should therefore be considered.

Water for animals should have the same hygiene standard as water for human consumption. Spreading of liquid manure on pastures, especially after heavy rain, might cause contaminated water to stand on low-lying surfaces. Cattle often drink from such water surfaces. The author has experience of mastitis outbreaks in dairy herds where the cows have used such pools for drinking, and also in dairy herds where the pastures have been flooded with sewage water.



## 6. The impact of feeding, drinking, bedding and waste management

Many watercourses and streams, which one hundred years ago could provide animals at pasture with clean drinking-water, are nowadays polluted by effluents from industrial, public or private outlets. This means that farmers must often fence in them and transport drinking-water to the animals.

### **6.2.5 Conclusions regarding the impact of feeding and drinking management on animal health, welfare and performance**

Feeding and drinking management must meet the basic biological and behavioural requirements of each species described in this chapter. Water for animals should have the same hygiene standard as water for human consumption. Hygienic measures are described for avoiding risks of transmission of toxins or pathogenic agents, especially *E. coli*, *Salmonella*, *Listeria*, but also *Clostridium* via feed or water. Repeated use of a pasture year after year causes risks of spreading infection via the soil or vegetation-surviving parasites. Bacterial pathogens which are health risks for humans are widespread in farm animal herds in several countries. This must be considered when manure is spread on pastures. Spreading liquid manure on fields intended for harvest of silage may impair the silage quality.

## **6.3 The impact of bedding management and flooring on animal health, welfare and performance**

### **6.3.1 Flooring and bedding**

In older times, a hard trodden earth floor was the usual flooring, and the animals lay on small piles of straw on this surface. Gradually, wooden floors came into use and in certain areas stone floors. This flooring was replaced by concrete, which is now practically the only flooring used. Clay and wood are poor heat conductors, while concrete is an efficient heat conductor. Concrete is easy to clean and disinfect.

When concrete began to come into use the farmers could afford to use more bedding for cattle and pigs. The hygienic advantage of concrete was thereby combined with protection against thermal losses through heat insulation and protection against injuries caused by the hard and slippery concrete surface. The bedding materials used are straw, chaff, sawdust, planing shavings, and peat litter. Chaff is nowadays practically never used as it will be left on the field by the combine harvesters, whereas the straw can be gathered in bales. In the 1960s rubber mats started to come into use in order to replace bedding, and also in order to avoid the often slippery surface of concrete.

Farmers have tried to diminish the costs of straw bedding, by either diminishing the amounts of bedding, or by using other materials, mostly sawdust. Sand is sometimes used as bedding in cubicles for cattle. In poultry houses, where the animals are kept loose, planing shavings are a commonly used material. Some manure handling systems make it difficult, or impossible, to use straw as bedding. Chaff was traditionally regarded as the most suitable litter for poultry. Nowadays sawdust, wood shavings, peat litter, or sometimes even sand, are used as litter in housing for egg-laying hens. If straw is used it must be chopped. Sawdust is nowadays seldom



## I. Ekesbo

used for poultry. However, shavings from wood impregnated with chemical substances should not be used because of risks of toxic characteristics. Beside this there are risks of getting changing the taste of the chicken meat.

Straw has better heat-isolating properties than most other bedding materials. In addition, it gives a better protection – a better mattress – especially for cattle and pigs, than practically any other material. However, labour costs make many farmers use sawdust both in tie stalls and in cubicles. When rubber and similar mats are used the requisites for heat insulation, as well as a soft lying surface are less than when on concrete flooring.

### 6.3.2 Bedding and behaviour

#### *Horses*

Horses seem to avoid urinating on hard surfaces. Instead they choose surfaces like soft soil, grass, or indoor bedded areas. Horses, after having been out on frozen land for a long time, may urinate in the bedding of the box immediately after having been brought indoors (Fraser, 1992).

#### *Cattle*

If having a free choice cows avoid wet laying surfaces (Fregonesi *et al.* 2007) and lying time is shorter on wet than on dry bedding (Reich *et al.* 2010). In cold and wet weather cattle also seek dry lying areas (Wassmuth *et al.* 1999).

If they have a free choice cows avoid wet laying surfaces, and lying time is shorter on wet than on dry bedding. In cold and wet weather cattle also seek dry lying areas. Results from many studies show that cattle prefer surfaces with bedding to surfaces without bedding and soft surfaces to hard ones (Ekesbo, 2011).

Cows prefer concrete stalls when bedded with 4 to 5 kg of straw, but choose mattresses when little bedding remains on the concrete (Jensen *et al.*, 1988). Cows significantly prefer cubicle stalls with 12 cm bedding of short-cut straw to cubicles with comfort-mattresses or rubber mats (Voigt *et al.*, 2007).

However, in a choice between stalls with about 20 cm layer of fine sand placed on a sand base of particles of different sizes and stalls with a concrete floor or with rubber mats they showed no preference for sand stalls (Norrning *et al.*, 2010). Cows with rubber mats or mattresses without bedding as the stall base have a higher percentage of severe hock lesions compared with cows with dirt as the stall base (Lombard *et al.*, 2010). Animals on straw-bedded surfaces showed less atypical lying down movements and difficulties when standing up than animals in the other systems. A comparison between free stalls and open laying area both covered with a 10 cm layer of sand showed that cows spent more time lying and standing fully in an open pack than in stalls. (Absmanner *et al.*, 2009).

## 6. The impact of feeding, drinking, bedding and waste management

### *Pigs*

Domestic pigs living in a semi-natural environment spend more than half of the daylight period foraging (rooting and grazing) and nearly 25% in locomotion and direct investigation of environmental features. Rooting is thus an exploratory behaviour of high priority in pigs. Exploratory behaviour in pigs is best stimulated by materials that are complex, changeable, destructible, manipulable, and contain sparsely distributed edible parts. The allocation of straw stimulates exploratory behaviour and reduces the amount of abnormal exploratory behaviour redirected towards pen mates, such as aggression, tail biting and stereotypies. The more straw there is available, the more exploratory behaviour is directed towards the straw (Ekesbo, 2011).

Abnormal behaviour, 'belly nosing', ear and tail biting, usually occurs in early weaned piglets, especially if kept in barren environments without straw bedding (e.g. Algers, 1984b). Such behaviour is very seldom seen in healthy piglets weaned after five weeks of age and kept loose in pens with access to straw.

Sows confined in closed un-strawed stalls show higher amounts of stereotypy incidence and aggression than those group-housed in strawed pens. These differences seem to increase from the first until the fourth pregnancy. Provision of straw to the sow before parturition has a positive effect on the behaviour of the sow, both during and after parturition which affects the survival of the piglets. Piglet creep areas without any bedding are associated with a higher mortality rate than those with bedding. The provision of straw of any length reduces the occurrence of behaviours such as nosing other pigs, aggression and tail-biting compared with pigs with no access to straw. Chopped straw increases the prevalence of behaviours such as licking, and decreases the prevalence of behaviours such as picking, suggesting that pigs are not able to manipulate the chopped straw in the same way as full-length or half chopped straw. In addition, levels of tail-biting are higher in groups that are provided with chopped straw compared to groups with full-length or half chopped straw (Ekesbo, 2011).

Pigs kept outdoors all the year around, without any supplementary feed, are shown to use 6-7 hours per day for foraging. Pigs kept indoors on commercial farms might use about 30 minutes daily for feeding, and even if their nutritional needs are fully covered they attempt to meet their behavioural need to further forage for food. This need might be strengthened by hunger if restricted feeding is applied, which is often the case in modern pig production. If straw, or other edible material, is used as bedding, these behavioural needs might be met by rooting and manipulating the bedding material. If such material is not available to them, stereotype behaviours will develop. Piglets, especially if early weaned or kept in a barren environment usually perform stereotypies and vacuum activities, very rarely seen in piglets kept loose in pens with access to straw. Included in the effects of environmental enrichment is decreased general fearfulness or fear of novelty (Ekesbo, 2011).

Domestic pigs always choose dry lying areas. If bedding material, e.g. straw, is available, they arrange their lying areas there. Group-housed sows show a significant preference for lying areas covered with soft mats compared to bare concrete floors. Studies of litters, with and without access to bedding, show that pigs not only prefer bedding but also those piglets were significantly

## **I. Ekesbo**

quicker to reach the udder after birth in premises with bedding than in such conditions without. Pigs kept indoors should be given the possibility to perform three different behaviours – feeding, resting and excretion – in separate parts of the pen (Ekesbo, 2011).

Shortly before parturition the female pig is strongly motivated to build a nest. One or two days before parturition domestic sows kept in a (semi-)natural environment leave the herd and can walk 2.5 to 6 km outside the home range, until they find one or more suitable nesting sites, and start building a bed or a nest. They use a variety of materials such as grass, straw, twigs and branches for nest building. Straw is thus important for nest building behaviour by sows housed indoors (Ekesbo, 2011).

### *Rabbits*

In the wild the female rabbit, the doe, always blocks the entrance of the nest after each visit to the pups. Under most commercial husbandry conditions, the entrance to the nest box is not closed as it is under natural conditions, but stays permanently open, potentially counteracting a doe's behavioural goal of a closed nest. Due to a non-manipulable floor without bedding and the absence of roughage or other appropriate materials to close the nest entrance, a doe will fail to achieve the feedback of a successful removal of nest stimuli, despite conducting the appropriate behavioural patterns. This leads to repeated nest contacts, nest visits and nest-closing attempts, and can increase pup mortality due to the crushing of pups, out-of-time pup activation or sucking and the disturbance of their energy-saving strategy of resting deep inside the insulating nest material between nursing visits (Ekesbo, 2011).

### *Domestic fowl*

Hens have retained the food searching behaviour that characterizes the jungle fowl; pecking with the beak and scraping with their feet and claws after feeding. Preventing them from performing this essential behaviour by keeping them on an entirely net floor involves disease risk.

Dust bathing is performed once every 2-3 days and consists of birds lying and rubbing litter material through their feathers. Dust-bathing presumably regulates the amount of lipids on feathers and maintains the good condition of the down structure. The presence of a suitable substrate is an important stimulus for eliciting dust bathing, and hens seem to prefer substrates with a fine structure such as sand and peat (Ekesbo, 2011).

### *Turkeys*

Domestic turkeys, if given the opportunity, will exhibit the same wide range of comfort and grooming activities as their ancestors, including preening, which involves the arrangement, cleaning and general maintenance of the structure of the feathers by the beak or feet; raising and ruffling the feathers; stretching the wings; and dust-bathing. The complete pattern may not be carried out by birds on concrete floors in the absence of litter, and by young birds which have never had any experience with litter (Ekesbo, 2011).

## 6. The impact of feeding, drinking, bedding and waste management

### 6.3.3 Hygienic and health aspects on flooring and bedding materials and their handling

#### Horses

Different types of bedding for horses have been tested. Used newspaper has been tested together with several other bedding materials: peat, straw, wood shavings, sawdust and others. Peat has the best qualities as an ammonia absorbent, water absorbent, and soluble nitrogen container. The weaknesses of peat are its heterogeneous quality, dark colour, and dust. Used newspaper gave the highest concentrations of breathable ammonia (Airaksinen *et al.*, 2001; Ward *et al.*, 2001).

Hoof diseases in horses might be caused by keeping the horse in an unsuitable environment. Thrush is a bacterial infection that occurs on the horse hoof, specifically in the region of the frog. It might affect horses kept in wet, muddy, or unsanitary conditions, such as dirty bedding in the box or stall.

#### Cattle

Mastitis causes more economical losses than any other cattle disease except the epizootic diseases. The main aetiological factor for mastitis is traumatic teat injuries, mainly teat tramp. The incidence of mastitis is also related to the degree of bacterial contamination of the teat, and especially the teat end. If dairy cows must lie on concrete, or similar hard areas, they run an increased risk of trampling their teats compared to cows where the lying area is supplied with enough soft bedding. If the stall is short, or if the lying area is slippery, there is an increased risk of similar injuries occurring when the cow is lying down or getting up (Bendixen *et al.*, 1988; Ekesbo, 1966).

It is difficult to keep cattle clean without dry bedding. A study of English dairy herds with permanent deep straw yards, over two winter periods, showed that much of the straw stored for bedding was too wet as it had a moisture content of more than 15%. *E. coli* and *Streptococcus uberis* counts were higher in beds where the cows had loose faeces than in beds where the cows had firmer faeces. Cows with loose faeces were dirtier than cows with firmer faeces. The herds with the lowest incidence of mastitis had the cleanest cows and the most satisfactory beds. In addition to the initial moisture content of the straw bales, considerable quantities of water are added daily to the straw through the cows' faeces and urine. High-yielding cows produce up to 30 litres or more of urine daily and a similar amount of water in faeces. In 340 British herds a significant association was found between higher rates of mastitis in cows housed in straw yards as opposed to cubicles, and also between higher rates of lameness in cows housed in cubicles as opposed to yards. However, there were farms with low rates of mastitis in cows kept in straw yards and low rates of lameness in cows kept in cubicles. Because bacterial infection from the environment is involved, clean, dry bedding, good ventilation, regular mucking out, and keeping the cows out of the lying areas for 30 minutes after milking are all important factors in helping to prevent mastitis (Bannink *et al.*, 1999; Ward *et al.*, 2002; Whitaker *et al.*, 2000).

Use of stored, not completely dry, sawdust means hygienic risks. Accumulated *E. coli*, *Klebsiella* or *Serratia* mastitis cases have been reported in herds where some of these infections have been established in damp sawdust used as bedding. Bedding stored outside will thus increase mastitis

## I. Ekesbo

risk. In herds with *Serratia* mastitis suspicions have been expressed that this also might be derived from dry sawdust. Studies of Unnerstad *et al.* (2009) show that isolation of *Klebsiella* spp. was strongly associated with the use of sawdust as bedding material, it was four times higher when sawdust was used as bedding compared to straw. *E. coli* in udder milk samples from cows was higher in loose housing systems than in tie stalls. Sawdust is more commonly used for bedding in loose housing than in tied housing. Bacteriological examination of sawdust bedding has shown *Klebsiella* spp and *Listeria monocytogenes* in sawdust bedding but not in straw bedding (Peinhopf and Deutz, 2005).

Risk factors for cow dirtiness in free stall housing are: no bedding compared with use of sawdust as bedding and liquid manure compared with more solid manure. The mid-sectors in the cubicles are at most risk of contamination from dirty feet, whereas the side sectors were at most risk of being contaminated by faeces. Studies of the influences on free stall cleanliness by different factors show that the amount of bedding is the most important factor. Even a minor amount of sawdust is better than nothing at improving stall cleanliness. Liquid manure is associated with an increased risk of dirtiness compared to more consistent manure (Ruud *et al.*, 2010, 2011).

Loose-housed cows in free-stalls show a greater prevalence of hock lesions than those housed on permanent straw bedding (Rutherford *et al.*, 2008).

Cows kept in cubicles with soft lying mats, and no or very little bedding, had a significantly higher incidence of both hairless patches and scabs or wounds located on the tarsal joints than cows in cubicles with straw bedding (Fulwider *et al.*, 2007; Wechsler *et al.*, 2000).

Cubicle refusal leads to soiling of the cow's udder and belly with urine and faeces, from lying in the dirty passageway, and increases the risk of udder contamination with a number of potentially pathogenic faecal bacteria, for instance *Escherichia coli*. Cubicle refusal is associated with heifers being reared in slatted floor accommodation. Cubicle refusal behaviour constitutes a mastitis risk factor. The incidence of *E. coli*-associated mastitis is higher in wet and dirty, than in dry and clean dairy housing. Animals which choose to lie in the passageway are at a higher risk of developing mastitis than cows which choose to rest in cubicles (Bartlett *et al.*, 1992; Ekesbo, 1966; Kjæstad and Simensen, 2001).

In herds with tied dairy cows the young stock and the heifers are often kept in loose housing on soft bedding. Heifers changing from the soft bedding to the hard flooring system need a long acclimatization period in order not to be affected by pressure injuries on the lateral part of the hock. Such injuries are often followed by complications in the form of infections which might lead to purulent abscesses (Bergsten *et al.*, 2009; Ekesbo, 1966).

Among housing factors influencing the prevalence of lameness in cubicle loose-housed dairy cows the lying surface is the most important factor in that straw bedding with a thickness of at least 2 cm, or cow comfort mats, are associated with a lower percentage of lameness (Rouha-Müelleder, 2009).

## 6. The impact of feeding, drinking, bedding and waste management

Heifers before calving and first calvers on hard flooring (cubicles without bedding) have higher growth and wear rate of claws and a higher prevalence of sole haemorrhages and dermatitis than heifers on deep straw bedding, which suffered from overgrown claws and more heel horn erosion. Leg lesions were only observed in the cubicle system. Animals on concrete slats, compared to those on rubber slats, have higher risk of lameness, sole haemorrhage, sole ulcer and white line haemorrhage. Thus soft floors are beneficial for cow's claw and leg health (Bergsten *et al.*, 2009).

There are different qualities of sawdust and wood shavings. The author has observed that some types of sawdust and wood shavings can presumably cause small wounds, especially on the lateral part of the hoof whereas other types do not. Such injuries occur especially when the sawdust or wood shavings are used in thin layers on concrete surfaces.

In order to prevent making the lying surface dirty, passageways leading back to the resting area should be scraped clean before the cows walk along them.

### *Sheep*

New-born and young lambs (and calves) are adversely affected by cold, wet and windy conditions, some breeds being more affected than others. Therefore dry lying areas, protected against precipitation, are necessary for lambs not to succumb to discomfort. If such protected areas are available the sheep seek protection in these from wind and rain. For sheep kept indoors lamb mortality is low, 2-3%. If kept outdoors without a dry lying area with sufficient protection against wind and precipitation, bad weather is an important cause of high lamb mortality, of 15-20%. Sheep kept on moist pastures or dirty bedding indoors, which irritate the sensitive skin in the interdigital cleft, might be affected by foot rot, one of the most common health and welfare problems in sheep husbandry (Ekesbo, 2011).

### *Pigs*

There is a relationship between the duration of long uninterrupted lying bout times after farrowing and the occurrence of shoulder lesions, even in well-conditioned sows provided with a small amount of straw present at the time of farrowing. Injuries caused by lying on the side on concrete or perforated floors without bedding might become infected and this can result in purulent abscesses. Poor concrete floor quality in the lying area can cause severe claw injuries to new-born piglets (Ekesbo, 2011).

Early weaned piglets confined in cages without bedding or other stimuli usually perform tail biting (Algers, 1984a). Tail biting behaviour usually starts soon after weaning and continues until slaughter. However, tail biting also often starts in piglets weaned after five weeks of age if kept in barren environments, e.g. pens with slatted or perforated flooring without access to straw.

There is an increased risk of abnormal posture in pregnant sows housed on slatted floors compared with those housed on solid concrete floors with straw bedding, or sows housed outdoors on soil. The prevalence of movement disorders, claw damage and other leg injuries is higher on concrete floors without bedding than on bedded floors. So, housing sows on solid floors instead

## I. Ekesbo

of on slatted flooring might reduce the risk of abnormal posture and certain foot lesions in sows. The lowest prevalence of abnormal gait in finishing pigs occurs in pigs housed outdoors. In indoor-housed finishing pigs, there is an increased risk of abnormal gait in pigs kept on solid concrete floors with sparse bedding, partly-slatted floors or fully-slatted floors compared with those housed on solid concrete floors with deep bedding in all areas. (KilBride *et al.*, 2009; 2010)

When sows and piglets are kept on concrete floors the piglets show a similar prevalence of lesions to the carpus as piglets on rubber mats, but the wounds on the mats are deeper and larger (Gravås, 1979). The morbidity and the mortality of pigs (Hoogerbrugge, 1987) and piglets (van Veen *et al.*, 1985) are increased when they are housed on slats compared with straw.

It is possible to keep adult sows and fattening pigs outdoors in low temperatures, provided that they have access to a dry straw lying area protected against precipitation and draughts. Piglets older than 1-2 weeks can withstand low temperatures. In cold ambient temperatures adult pigs, during their resting periods – and piglets always, apart from when suckling – nestle down into the bedding material. If such bedding does not exist they creep close together, young piglets even try to lie on the belly of the sow. In their studies of the thermal microclimate in winter farrowing nests of free-ranging domestic sows and their litters Algiers and Jensen (1990) found that when the outdoor temperature varied between -17 °C and 7 °C the nest temperature, measured 5 cm from the piglets, varied between 11 °C and 26 °C, with an average of 20.3 °C. Pigs are significantly quicker to reach the udder after birth in premises with bedding than in such without (Ekesbo, 2011).

The type of floor influences the thermal resistance between the pig's body temperature and the floor temperature. The effective critical temperature for 40 kg pigs is 11.5-13 °C on straw bedding, 14-15 °C on asphalt, and 19-20 °C on concrete slats. With a temperature under the lower critical temperature (LCT) the pig must use a larger part of its turnover of body energy to increase its total heat production. When pigs are embedded in straw the LCT can be quite low. Sows kept in cages in un-insulated buildings, without bedding and without body contact and thereby some warmth from other sows are reported to be subject to abortions during the cold season (Ekesbo, 2011).

### *Domestic fowl*

Access to litter during the rearing period has an important effect in reducing the amount of feather pecking in adults. This effect can be either through redirected ground pecking or abnormal dust-bathing in the birds deprived of litter during rearing. Feather pecking can be prevented by offering an adequate substrate, which should also be included in the rearing period (Ekesbo, 2011).

The prevalence of foot pad dermatitis at time of slaughter is estimated to be 5-10% for severe lesions, and 10-35% for mild lesions, in Swedish broiler chickens. There is a positive association between bad litter quality and insignificant litter depth and the prevalence of foot pad dermatitis in broilers (Berg, 1998).



## 6. The impact of feeding, drinking, bedding and waste management

Poorly managed bedding produces ammonia. Ammonia concentrations at 25 and 50 ppm induce eye lesions in young broiler chickens after day 7 of initial exposure (Ekesbo, 2011).

### *Turkeys*

High litter moisture alone is sufficient to cause footpad dermatitis in young turkeys, and it has been shown that footpad dermatitis can be minimised by the maintenance of dry litter. The prevalences of foot-pad dermatitis in Swedish turkey flocks in the 1990s were 20% for severe lesions, and ulcers, and 78% for mild lesions. Only 2% of the feet were classified as being without lesions. It is often necessary to add fresh litter during the rearing period to keep the litter quality dry enough, especially if turkey poults are kept until 18-20 weeks of age or longer. It has been indicated that the use of under-floor heating can substantially improve litter quality, and thereby turkey foot health (Ekesbo, 2011).

### **6.3.4 Conclusions regarding the impact of bedding management and flooring on animal health, welfare and performance**

- Horses need bedding when kept indoors.
- Access to a bedding material which affords rooting and similar exploratory behaviour is a necessity for all pigs in order to avoid disorders. Access to straw as bedding for sows before parturition is necessary for the performance of nest building behaviour.
- Irrespective of flooring material dairy cows must get enough bedding in order to avoid traumatic injuries, which in turn might lead to infections, e.g. mastitis. Cattle prefer straw over other bedding materials, but sawdust over sand. Use of stored, not completely dry, sawdust as bedding for dairy cows means mastitis risks. Cattle, when changing from soft bedding to a hard flooring system, need a long acclimatization period in order not to be affected by pressure injuries on the lateral part of the hock. The incidence of infectious hoof disorders in horses, mastitis in cows, claw disorders in sheep and goats, and foot pad dermatitis in broiler and turkeys is higher for animals kept on wet and dirty bedding than on dry and clean bedding.
- Keeping hens on an entirely net floor involves a disease risk. Domestic fowls and turkeys kept indoors must have access to bedding for their essential behaviours of food searching and dust bathing.
- For animals kept outdoors during the cold part of the year a dry lying area is a necessity.

## **6.4 The impact of waste management on animal health, welfare and performance**

### **6.4.1 Handling methods for manure, urine and wastes**

Manure from domestic animals is a valuable resource in agriculture and was, together with human residues, used by early civilizations. Manure handling and storing methods are important factors which influence animal health and welfare. Pathogenic agents and other harmful components, which might be present in manure, constitute a potential hazard to both animal health and



## I. Ekesbo

welfare and public health. Knowledge of hygienic and health hazards related to manure handling therefore is a necessity.

In spite of the fact that farmers have lived with their animals in villages and towns, as still can be seen in parts of some countries, e.g. Austria, Germany and Switzerland, most farmers do not seem to have had problems with farm animal wastes until the second half of the 20<sup>th</sup> century. In the old farmer society the dung heap was often situated on the front side of the cow house along the village street. A well-kept, odour-free and practically flyless dung heap was, in the traditional European farming society, a sign that the farm was well-run. Such a dung heap did not actually involve a hygienic nuisance for the neighbourhood, nor did the spreading of such composted manure.

Solid manure handling was traditionally used from horses, cattle, pigs, sheep, goats, pigs and poultry, since man kept farm animals housed for part of the year. The manure, mixed with used bedding, was usually removed twice daily from gutters, stalls and pens, and transported from the animal housing and stored outside. As most farms kept horses, cattle and pigs, the manure from the different species was mixed in the dung heap outside. Nowadays the stored manure, in practically all herds, originates from only one farm animal species, or even one age category, as a result of the change to increasing specialization in animal husbandry. With less bedding, and generally less dry matter content in the manure, there will be no composting process in stored cattle manure.

Nowadays, the coexistence of farm animal and even quite small villages often seems to be regarded as more and more irreconcilable, or, in other words, farm animal production units have often been regarded as a public nuisance. This is especially the case where traditional solid manure handling methods have been replaced by liquid manure handling, which emits malodorous fumes.

Urine was, in early times, mixed with the manure in the gutter, and then drained from the gutter via a pipe to a urine pit located beside the dung heap.

In poultry houses, where the birds were loose, permanent deep bedding was usually removed once a year, in the summer. In the poultry houses in use since the end of the 20<sup>th</sup> century the bedding is removed after each batch of chickens, before cleaning and disinfection of the room.

Cattle manure had a dry and solid consistency during the housing period in most herds until the 1950s. Increasingly more intense feeding strategies with less hay, practically no straw for feeding, and much more silage and concentrates has, especially for dairy cows, entailed consistently loose and far less dry faeces.

For solid manure handling in cattle and swine housing the manure is transported by scrapers in the gutters or alleys either directly to the dung heap or the scrapers run into a transverse culvert where scraper(s) convey the manure to the top of the dung heap outdoors. In some herds the transverse culvert is a pipe through which the manure is forced, by a hydraulic piston, out into the lowest part of the side of the dung heap, and therefore the fresh manure ends up practically under the dung heap. This 'mole-hill' system facilitates the composting process by the mixing of parts

## 6. The impact of feeding, drinking, bedding and waste management

of the heap which this method involves. This reduces the risk of malodour as the fresh manure usually ends up under already stored and thus drier manure. It also reduces the nuisance of flies, as the flies do not reach the fresh manure necessary for egg-laying purposes.

Solid manure is spread onto the soil and then ploughed into the soil, usually on fields to be sown. The urine is spread either on pastures or in fields with crops at an early growth stage.

Liquid manure handling came into use, on a limited scale, mostly in small cattle herds in southern Germany during the 1920s. During the 1960s the method was developed and marketed by the technical industry, and became introduced in pig and cattle herds, but also in herds with caged egg-laying hens.

Liquid manure is either transported as a slowly moving fluid or pumped and stored in a manure pit outside the animal housing. In some herds the liquid manure is stored in a manure basement under the floor of the animal housing. The liquid manure inside the house is transported either by scrapers, from the gutters or alleys to a transverse culvert from where it flows or is pumped to an outside pit. Or it slowly flows, or is pumped, from the gutters or passageways, into deep channels. When the slow flowing system is used water is usually added in order to facilitate the transport of the liquid. When the manure is pumped, the pump is usually situated in the outside manure pit. It pumps with intervals, of weeks or months; the stored manure from the pit into the ends of the gutter channels inside the animal house and by this means transports the stored manure to the outside pit. Manure channels are always covered with slatted floor or gratings. For tied cattle, even the gutters with scrapers are usually covered with gratings. For loose housed cattle and pigs, passageways with scrapers are either open or covered with slatted floors or gratings.

The solids content of liquid manure varies between 3.5% and 8.3% (Ford and Fleming, 2002). In order not to obstruct the manure flow, the supply of solid material should be avoided. Liquid manure handling therefore usually makes the use of only very small amounts of bedding possible.

Unlike solid manure handling liquid manure handling is an anaerobic process. Manure gases: methane, hydrogen sulphide, ammonia, and others are formed in the stored liquid manure. In the liquid manure pit a cover is formed on top of the stored manure. Before the emptying of the pit, this cover must be dispersed in order to get the manure to pump. During this period of stirring large quantities of manure gases are emitted.

Liquid manure is spread in the fields either on pastures or on the surface of fields to be sown. In order to avoid the malodours fumes emitted during and after spreading the manure is often injected in the ground.

Since the end of the 1970s equipment has been developed that is able to separate the liquid manure in the manure pit into a solid phase and a liquid phase. There are several different types of these separators. The dry matter content of the solid phase attained after such treatment varies between about 6% and 18% (Ford and Fleming, 2002).

#### **6.4.2 Health and hygienic aspects on manure, urine and waste storing and handling methods**

Composting is an aerobic, process involving microorganisms, which brings about a continuous increase in the temperature. It refers to a biodegradation process of a mixture of substrates carried out by a microbiological community, composed of various populations in aerobic conditions and in the solid state. The process passes through a mesophilic phase, between about 25-40 °C, followed by a thermophilic phase between about 35 and 65 °C. Finally comes the cooling phase or second mesophilic phase. The activity of the thermophilic microorganisms ceases at 65-70 °C. A continuing temperature increase, often to 75 °C, sometimes higher, is a result of chemical processes. Finally comes the cooling phase, or second mesophilic phase. The optimum water content is considered to be 50-60%, if less than 45% the microorganisms are less active and if more than 65% can bring about anaerobic conditions can result, unless the material contains abundant straw. The microorganisms exploit carbon for growth and as a source of energy, and nitrogen for the synthesis of protein. The relationship between carbon and nitrogen (the C/N ratio) is of great importance for the composting process. The optimum C/N ratio is 30; less than 35 slows the process, while less than 20 results in nitrogen losses in the form of NH<sub>3</sub>. Cattle manure without straw has a C/N ratio of about 10, which rises to 30 at a rate of 5 kg straw/cow/day. The composting process is further encouraged by using straw as bedding than if the same amount of straw is mixed afterwards in the manure heap. There is no doubt that the composting process, if properly applied, can inactivate some important pathogens. This involves the material having optimum moisture content, and a pH of about 7. Most of the humid vapours from the dung heap are a consequence of the generation of heat (Böhm, 2007; Insam and Bertoldi, 2007; Plym Forshell, 1996).

In older times, cattle manure mixed with straw usually had a high C/N ratio. When urine was added the composting process was facilitated. In modern cattle manure the C/N ratio is often low, because of the small amounts of added straw and the high nitrogen content in the manure. In modern cattle manure, adding urine therefore disrupts the composting process, while increasing the straw content facilitates it. At composting, the unpleasant smell which usually is emitted from fresh or liquid stored and spread manure from some species, especially pigs and poultry, disappears. Nowadays, there is usually no composting process of cattle manure, mainly because there is not enough straw bedding supplied, and there is often too high moisture content. The dry matter content in cattle manure is reported to be 13-15%. Pig manure has a higher dry matter content. Pig and horse manures are more likely to compost successfully than cattle manure (Plym Forshell, 1993).

At solid manure handling, early separation of the urine from the manure as soon as the urine has landed in the gutter or passageway, without mixing, is necessary to ensure that the urine pH is kept at about 9, which most infectious agents cannot survive for long. Such an efficient early separation also facilitates the possibility of keeping the cows and their housing environment clean, reduces the risk of formation of NH<sub>3</sub>, and promotes the composting process. If the urine is mixed with manure the pH will be neutral which thus facilitates the survival and growth of infectious agents during storage in the urine pit (Plym Forshell and Ekesbo, 1996).

## 6. The impact of feeding, drinking, bedding and waste management

The risk of spreading contagious agents from a herd to the environment is a threat to animal and human health. Although it might occur via vented air from the housing it mainly takes place via manure and other waste products, e.g. afterbirth, dead animals, etc. Solid manure handling with an efficient composting process, and early separation of urine, means that the infection chain from the animal house into the environment can be broken for most infectious agents. But a prerequisite is that there is a composting process (Plym Forshell and Ekesbo, 1993). Solid manure handling also gives the flexibility to use different sorts of bedding, and different amounts of bedding.

Handling of solid manure has, compared to liquid manure handling, been subject to only limited research, and very little has been invested in its technical development despite this method of handling still being common. However, there are some results of studies of the hygienic aspects of solid manure handling available. The aim to increase the dry matter content of the stored manure by adding straw seems to be of less importance for heat development than adding straw via the bedding to the manure. Composts with pig manure and straw have higher temperatures than composts with cattle manure and straw (Plym Forshell, 1993). The temperature in composts, where urine is separated from the manure in the gutter, is higher than in composts from animal houses where this does not occur (Ekesbo, 1979).

So called pressure systems for the transport of solid manure have hygienic advantages during storage of the manure. Pig manure, even from fattening pigs, from which urine is separated in the dung alley, can be easily handled as solid manure (Ekesbo, 1979).

Urine, directly and passively separated in the gutter without actively being mixed with the manure, has a higher pH, often about 9, than liquid manure, even when the dry matter content is higher than in liquid manure. In such urine there thus does not seem to be any association between dry matter content and pH. The pH in liquid manure is usually about 7 (Ekesbo, 1979).

In composted cattle manure survival of *Salmonella* Dublin and *Salmonella* Typhimurium was less than seven days but in uncomposted manure the survival period was 183 days for *Salmonella* Dublin and 204 days for *Salmonella* Typhimurium. As *Salmonella* can survive for a long period in uncomposted solid manure, it therefore should be regarded as being similar to liquid manure (Plym Forshell and Ekesbo, 1993). In composted chicken manure, survival of coccidia oocysts varied between 13 and 370 days, ascaris eggs between 53 and 347 days and *Salmonella* Typhimurium between 2 and 175 days. The tenacity of the investigated organisms mainly depends on the dry matter content of the manure. The longest period of survival of salmonellas was found in dry environmental conditions, whereas coccidia oocysts and ascaris eggs have been observed to have the shortest survival period (Roesicke and Greuel, 1992). *Salmonella* has been shown to survive for nearly six years in dried manure stall surfaces in cow housing without animals. *Salmonella* does not survive for longer than five days in urine separated in the gutter, and not mixed with manure (Plym Forshell and Ekesbo, 1996).

The survival period for *E. coli* O157:H7 is shorter in aerobic than in anaerobic manure, two weeks compared to six months (Semenov *et al.*, 2011). *Salmonella* incidence is lower in herds with solid manure handling than with liquid handling.

Separation of the urine from the manure in the gutter or the passageway with no mixing with the manure seems to involve advantages from the climate point of view inside the animal house, compared with when such separation does not occur. The separation of urine also involves hygienic advantages from a cleanliness point of view for the animals. Liquid manure handling does not provide the possibility to break the infection chain as composted solid manure or early separated urine do. On the contrary, some infectious agents might even be enriched during liquid manure storage.

Several studies have been published on the hygienic aspects of liquid manure handling. Pathogen microorganisms can survive, and in certain cases seem to be enriched, in stored liquid manure. *Salmonella* Dublin survived in cattle slurry for 31-33 weeks during the autumn, but only 19 weeks when similar slurry was infected in the spring. Variations in the survival of pathogenic bacteria in slurry are mainly due to the pathogen species and serotype, slurry composition, temperature and pH. It has been shown that *Salmonella anatum* survives for 56 days in swine slurry, and the pseudorabies virus survives for 26 weeks in liquid cattle manure. Chemical treatment can be used so that infectious agents can be killed. However, the methods are difficult to carry out for economic reasons (Ajariyakhajorn *et al.*, 1997; Biermann *et al.*, 1990; Findlay, 1972; Kearney *et al.*, 1993; Strauch, 1981; Wekerle *et al.*, 1986).

A British survey has shown that there is a one-in-three chance that a sample of livestock waste will contain either *Campylobacter*, *Listeria*, *Salmonella*, *Giardia*, *E. coli* O157, or *Cryptosporidium parvum* at mean levels of up to  $10^6$  g of waste. Leaving wastes on the surface increases the possibility that rainfall, heavy enough to cause surface runoff could wash pathogens and manures directly into watercourses where they are likely to last longer than those in terrestrial environments (Hutchison *et al.*, 2004).

Injection of the slurry into the soil is becoming more and more common. However, there seems to be longer survival in the soil than on the soil surface. Thus *E. coli* O157 inoculum levels of  $10^8$  declined to  $5 \times 10^6$  after 130 days in wastes applied to soil sown with grass under laboratory conditions (Maule, 2000). This means that injection of liquid manure into the soil in order to avoid malodorous fumes might involve risks of persistence of infectious agents.

Transmission of *Salmonella* and *Trichostrongylus* infections can occur via pastures where infected liquid manure has been spread (e.g. Jack and Hepper, 1969; Hess and Breer, 1975).

In soil fertilized with slurry inoculated with *E. coli* O157:H7 and *Salmonella* the former was found in all 50 of 50 samples, and the latter in 40 of 50 samples after two weeks. Fescue plant tissues in manure-contaminated soil were positive for *E. coli* O157:H7 after four days, and were still positive on day 14, and 21% of lettuce after 15 days (Looper *et al.*, 2009; Mootian *et al.*, 2009). *E. coli* generally persist in manure-fertilized soil for more than 100 days, and have been detected in soil 132 to 168 days after manure application (Ingham *et al.*, 2004). The use of animal wastes for fertilization of crops increases the risk of *E. coli* contamination in farm produce significantly. Improper ageing of untreated animal manure significantly increased this risk in agricultural produce grown using such manure as a fertilizer. There are significantly greater risks of contamination with *E. coli* when cattle manure is used for fertilization of the crops than when

## 6. The impact of feeding, drinking, bedding and waste management

other types of manure-based fertilizer are used (Mukhejee *et al.*, 2007). After a 1<sup>st</sup> June manure application, *S. enterica* serovar Typhimurium was detected in the soil on the 7<sup>th</sup> September, and on radishes and rocket leaves planted on the 15<sup>th</sup> August and harvested on the 27<sup>th</sup> September (Natvig *et al.*, 2002).

In these circumstances the frequent occurrence of *Salmonella*, *E. coli* O157:H7 and other infectious agents in animal herds in many countries is alarming. It is estimated that 2 to 4 million cases of salmonellosis occur in the US annually, and that animal food products are the main sources of salmonellosis in humans (Bicudo and Goyal, 2003). From North America some figures are available. In 46% of 80 swine farms *Salmonella* were recovered (Farzan *et al.*, 2008). In another study 77% of farms had at least one positive sample. *Salmonella* was, in this study, more likely to be detected from manure pit samples compared to fresh samples (Farzan *et al.*, 2010). For broiler chickens an infection rate of 50% has been reported, and for turkeys 54% (Arsenault *et al.*, 2007). According to an EFSA report (EFSA, 2007) the incidence of *Salmonella* in EU flocks varies in the different member countries as follows: laying hen flocks from 0% to 31%, broilers from 0.2% to 66%, turkeys from 0% to 14%, pigs from 0% to 55%, and cattle from 0% to 7%.

Different experiments with providing an air supply to liquid manure, in order to achieve aerobic conditions, have not yet given entirely safe results regarding the killing of pathogenic microorganisms of the type *Salmonella* or *Ascaris suum* eggs (Plym Forshell, 1995).

Animals in liquid manure housing have higher morbidity than animals in houses with solid manure handling. The prevalent difficulties of using ample amounts of bedding in connection with liquid manure handling, whether this be straw or anything else, has a negative effect on the animals' health (Ekesbo, 1966; Ekesbo and Högsved, 1976).

Manure gas poisoning has been reported from herds where liquid manure is used. Handling liquid manure inside an animal house makes very great demands on the ventilation system in order to avoid manure gas intoxication. Hydrogen sulphide especially is very toxic, and even a trace of it causes health hazards for animals and man. The chronic symptoms are often diffuse, with early abortion, lameness, and subcutaneous bleeding. The chronic symptoms in animals usually appear in houses where the manure is stored in deep liquid manure gutters, canals behind tied animals or in basins under the loose-housed herds. The acute symptoms are unconsciousness and, if immediate countermeasures are not taken, death. Many cases have been reported where animals have died. There are also cases reported where people have died. There are several examples of people who have entered liquid manure pits to check on equipment, etc. and thereupon have been killed by the manure gases. Acute symptoms occur when the manure is pumped, when the gutters are drained or when the manure in the basins is stirred in order to make it possible to pump (Bengtsson *et al.*, 1965; Björklund *et al.*, 1972; Bleie, 2001; Ekesbo, 1966; Ekesbo and Högsved, 1976).

### **6.4.3 Conclusions regarding the impact of waste management on animal health, welfare and performance**

- The United Nations Food and Agriculture Organisation (FAO) have prepared 'Guidelines concerning hygienic animal manure handling' (FAO, 1985). This report was sent to governments in Europe and USA in 1986. Parts of this may serve as conclusions for this section.
- The liquid manure (slurry) from normal healthy herds, without diagnosed notifiable or reportable diseases, should be stored for prophylactic reasons for at least seven days without addition or removal (incubation periods) before utilization, which requires two storage tanks. It is advisable to provide a storage capacity in these two tanks sufficient for at least five months.
- The minimum storage time for liquid manure before distribution on grazing land should be 60 days.
- Any crops can be irrigated by liquid manure except for those for human consumption.
- If slurry is spread on grassland the possible adverse effects on silage quality should be considered. Such a negative influence is not reported for urine.
- If slurry is spread on grazing land then there should be a delay 30 days before grazing with susceptible animals.
- The risk that pathogens from manure may survive longer in the soil than on the soil surface should be considered. Pathogens from manure may survive in soil up to five months, sometimes longer, depending on climatic conditions.
- Microbial aerosols are emitted in the air by spray irrigation of slurry. Such aerosols may travel over large distances depending upon atmospheric conditions. This method of distribution should therefore be abandoned.
- The disposal of untreated, and also pre-treated, liquid manure into surface waters such as rivers, lakes, the sea, etc. should not occur.
- The risk for animal health of the deposition of heavy metals on the field or onto crops via liquid manure should be taken into consideration. One example is copper-intoxication in sheep grazing fields fertilized with liquid manure from pigs given feed containing copper as growth promoter.
- In order to avoid manure gas intoxication, or the spread of infectious diseases, contact between the animals and the manure or its aerosols must be strictly avoided. Storage or transport of liquid manure in dung channels inside animal housing involves great health risks through gas intoxication. Therefore manure scrapers should be used in passageways, etc. in animal housings.
- It is advisable to separate urine as early as possible in the handling system, i.e. in the gutter or dunging alley, and thus avoid active mixing of solid manure and urine, e.g. by scrapers. Urine should preferably be stored separated from the solid manure in a urine tank.

### **References**

- Absmanner, E., Rouha-Mulleder, C., Scharl, T., Leisch, F. and Troxler, J., 2009. Effects of different housing systems on the behaviour of beef bulls-An on-farm assessment on Austrian farms. *Applied Animal Behaviour Science* 118: 12-19.



## 6. The impact of feeding, drinking, bedding and waste management

- Airaksinen, S., Heinonen-Tanski, H. and Heiskanen, M-L. 2001. Quality of different bedding materials and their influence on the compostability of horse manure. *Journal of Equine Veterinary Science* 21: 125-130.
- Ajariyakhajorn C., Goyal S.M., Robinson R.A., Johnston L.J. and Clanton. C.J., 1997. The survival of *Salmonella anatum*, pseudorabies virus and porcine reproductive and respiratory syndrome virus in swine slurry. *New Microbiologic* 20: 365-369.
- Alcock, M.B., 1992. Role in landscape and wildlife conservation. In: Phillips, C.J.C. and Piggins, D. (ed.) *Farm animals and the environment*. CAB International, Wallingford, UK, pp. 383-410.
- Algers, B. and Jensen, P., 1990. Thermal microclimate in winter farrowing nests of free-ranging domestic pigs. *Livestock Production Science* 25: 177-181.
- Algers, B., 1984a. Animal health in flat deck rearing of weaned piglets. *Zentralblatt Veterinary Medicine A* 31: 1-13.
- Algers, B., 1984b. Early weaning and cage rearing of piglets. Influence on behaviour. *Zentralblatt Veterinary Medicine* 31: 14-24.
- Arsenault, J., Letellier, A., Quessy, S., Normand, V. and Boulianne, M., 2007. Prevalence and risk factors for *Salmonella spp.* and *Campylobacter spp.* caecal colonization in broiler chicken and turkey flocks slaughtered in Quebec, Canada. *Preventive Veterinary Medicine* 81: 250-264.
- Bahnson, P.B., Fedorka-Cray, P.J. Ladely, S.R. and Mateus-Pinilla, N.E. 2006. Herd-level risk factors for *Salmonella enterica* subsp. *enterica* in U.S. market pigs. *Preventive Veterinary Medicine* 76: 249-62.
- Bannink, A., Valk, H. and Van Vuuren, A.M., 1999. Intake and excretion of sodium, potassium and nitrogen and the effects of urine production by lactating dairy cows. *Journal of Dairy Science* 82: 1008-1018.
- Bartlett, P.C., Miller, G.Y., Lance, S.E. and Heider, L.E., 1992. Managerial determinants of intramammary coliform and environmental streptococci infections in Ohio dairy herds. *Journal of Dairy Science* 75:1241-1252.
- Bendixen, P., Vilson, B., Ekesbo, I. and Åstrand, D.B., 1986. Disease frequencies of tied zero-grazing dairy cows and of dairy cows on pasture during summer and tied during winter. *Preventive Veterinary Medicine* 4: 291-306.
- Bendixen, P., Vilson, B., Ekesbo, I. and Åstrand, D.B., 1988. Disease frequencies in dairy cows in Sweden. V. Mastitis. *Preventive Veterinary Medicine* 5: 263-274.
- Bengtsson, G., Ekesbo, I. and Jacobsson, S.O., 1965. An outbreak of disease in cattle, presumed to have been chronic hydrogen sulphide poisoning. *Svensk Veterinärtidning* 17: 248-254.
- Berg, L., 1998. Foot-Pad dermatitis in broilers and turkeys – prevalence, risk factors and prevention. Thesis. *Acta Universitatis Agriculturae Sueciae, Veterinaria* 36: 85 pp.
- Bergsten, C., Telezhenko, E. and Ventorp, M., 2009. Importance of soft and hard flooring system for claw conformation, locomotion, claw- and leg health in heifers and first calvers. *Proceedings of the 14<sup>th</sup> International Congress of the International Society for Animal Hygiene (ISAH)*, Vechta, Germany, pp. 387-390.
- Bicudo, J.R. and Goyal, S.M., 2003. Pathogens and manure management systems: a review. *Environmental Technology* 24: 115-130.
- Biermann, U., Herbst, W. and Schliesser, T., 1990. The persistence of bovine enterovirus and pseudorabies virus in liquid cattle manure at different storage temperatures. *Berliner und Münchener Tierärztliche Wochenschrift* 103: 88-90.
- Binter, C., Straver, J.M., Häggblom, P., Bruggeman, G. and Lindqvist, P.A., 2011. Transmission and control of *Salmonella* in the pig feed chain: a conceptual model. *International Journal of Food Microbiology* 145: S7-S17.



## I. Ekesbo

- Björklund, N-E., Högsved, O., Lindahl, O. and Sällvik, K., 1972. Gödselgasförgiftning i kalvbesättning – a liquid manure gas poisoning in a calf herd. (English summary), *Svensk Veterinärtidning* 24: 616-619.
- Bleie, E., 2001. Gjødelselgassforgiftning. *Norsk Veterinærtidsskrift* 113: 637.
- Böhm, R., 2007. Pathogenic agents. In: Diaz, L.F., De Bertoldi, M., Bidlingmaier W and Stentiford, E. (eds.) *Compost science and technology*. Elsevier, Boston, MA, USA, pp 177-200.
- Bradley, A.J. and Green, M.J., 2001. Aetiology of clinical mastitis in six Somerset dairy herds. *Veterinary Record* 148: 683-686.
- Christodoulopoulos, G. and Roubies N., 2007. Diagnosis and treatment of copper poisoning caused by accidental feeding on poultry litter in a sheep flock. *Australian Veterinary Journal* 85: 451-453.
- Davies, P.R. Morrow, W.E.M., Jones, F.T., Deen, J., Fedorka-Cray, P.J. and Harris, I.T., 1997. Prevalence of *Salmonella* in finishing swine raised in different production systems in North Carolina, USA. *Epidemiology and Infection* 119: 237-244.
- Ducrot, C., Arnold, M., De Koeijer, A., Heim, D. and Calavas, D., 2008. Review on the epidemiology and dynamics of BSE epidemics. *Veterinary Research* 39: 39:15.
- Dwyer, C., 2009. The behaviour of sheep and goats. In: Jensen, P. (ed.) *The ethology of domestic animals – an introductory text*. CABI, Wallingford, UK, p. 161-176.
- EFSA, 2008. Microbiological risk assessment in feeding stuffs for food-producing animals. Scientific Opinion of the Panel on Biological Hazards. *The EFSA Journal* 720: 1-84.
- Ekesbo, I. and Högsved, O., 1976. Some results of health studies of calves in buildings with liquid and solid manure handling. *Proceedings 2. Congress of the International Society for Animal Hygiene, Zagreb, Croatia*, pp. 551-586.
- Ekesbo, I., 1966. Disease incidence in tied and loose housed dairy cattle and causes of this incidence variation with particular reference to the cowshed type. *Acta Agriculturae Scandinavica, Suppl.* 15: 74 pp.
- Ekesbo, I., 1979. A study of methods for handling and composting of cattle and swine manure and urine from the point of view of hygiene. *Agricultural Wastes* 1: 205-221.
- Ekesbo, I., 2011. *Farm animal behaviour – characteristics for assessment of health and welfare*. CAB International, Wallingford, UK, 237 pp.
- Ellis-Iversen, J., Smith R.P., Van Winden, S., Paiba, G.A., Watson E., Snow L.C. and Cook, A.J.C., 2008. Farm practices to control *E. coli* O157 in young cattle – a randomised controlled trial. *Veterinary Research* 39, DOI: [10.1051/vetres:2007041](https://doi.org/10.1051/vetres:2007041).
- FAO, 1985. Guidelines concerning hygienic animal manure handling. Elaborated on behalf of FAO by subnetwork 1 in the FAO network 'Animal waste utilization', Ekesbo, I. (ed.) Report 14, Swedish University of Agricultural Sciences, Faculty of Veterinary Medicine, Department of Animal Hygiene, Skara, Sweden, 11 pp.
- Farzan, A., Friendship, R.M., Cook, A. and Pollari, F., 2010. Occurrence of *Salmonella*, *Campylobacter*, *Yersinia enterocolitica*, *Escherichia coli* O157 and *Listeria monocytogenes* in swine. *Zoonoses and Public Health* 57: 388-396
- Farzan, A., Friendship, R.M., Dewey, C.E., Muckle, A.C., Gray, J.T. and Funk, J., 2008. Distribution of *Salmonella* serovars and phage types on 80 Ontario swine farms in 2004. *Canadian Journal of Veterinary Research-Revue Canadienne de Recherche Veterinaire* 72: 1-6.
- Fedorka-Cray, P.J., Hogg, A., Gray, J.T., Lorenzen, K., Velasquez, J. and Von Behren, P., 1997. Feed and feed trucks as sources of *Salmonella* contamination in swine. *Swine Health and Production* 5: 189-193.
- Findlay, C.R., 1972, *Salmonella* in sewage sludge: Part 11, Multiplication. *Veterinary Record* 14: 1567-1571.
- Fink-Gremmels, J., 2008, Mycotoxins in cattle feeds and carry-over to dairy milk: a review. *Food Additives and Contaminants* 25: 172-180.

## 6. The impact of feeding, drinking, bedding and waste management

- Ford, M. and Fleming, R., 2002. Mechanical solid-liquid separation of livestock manure. A literature review. Ridgetown College, University of Guelph, Guelph, ON, Canada, 55pp.
- Fraser, A., 2010. The behaviour and welfare of the horse, CABI, Wallingford, UK, 272 pp.
- Fraser, A.F., 1992. The behaviour of the horse. CAB International, Wallingford, UK, 288 pp.
- Fregonesi, J.A., Veira, D.M., Von Keyserlingk M.A.G. and Weary, D.M., 2007. Effects of bedding quality on lying behavior of dairy cows. *Journal of Dairy Science* 90: 5468-5472.
- Fulwider, W.K., Grandin, T. Garrick, D.J. Engle, T.E. Lamm, W.D. Dalsted, N.L. and Rollin, B.E., 2007. Influence of free-stall base on tarsal joint lesions and hygiene in dairy cows. *Journal of Dairy Science* 90: 3559-3566.
- Gravås, L., 1979. Behavioural and physical effects of floor on piglets and sows 5: 33-45.
- Heim, D., Fatzer, R., Hornlimann, B. and Vandeveld, M., 1997. Frequency of neurological diseases in cattle. *Schweizer Archiv für Tierheilkunde* 140: 240-249.
- Henry, C. and Knight, R., 2002, Clinical features of variant Creutzfeldt-Jakob disease. *Reviews in Medical Virology* 12: 143-150.
- Hess, E. and Breer, C., 1975. Epidemiology of *Salmonellæ* and fertilizing of grassland with sewage sludge. *Zentralblatt für Bakteriologie. 1. Abt. Originale. B, Hygiene* 161: 54-60.
- Hoogerbrugge A., 1987. Housing systems and health, *Tijdschrift voor Diergeneeskunde* 112: 1069-1074.
- Hutchison, M.L., Walters, L.D. and Moore, A., Crookes, K. M. and Avery, S. M., 2004. Effect of length of time before incorporation on survival of pathogenic bacteria present in livestock wastes applied to agricultural soil. *Applied and Environmental Microbiology* 70: 5111-5118.
- Ingham, S.C., Losinski, J.A., Andrews, M.P., Breuer, J.E., Breuer, J.R., Wood, T.M. and Wright, T.H., 2004. *Escherichia coli* contamination of vegetables grown in soils fertilized with noncomposted bovine manure: garden-scale studies. *Applied and Environmental Microbiology* 70: 6420-6427.
- Insam, H. and De Bertoldi, M., 2007. Microbiology of the composting process. In: Diaz, L.F., De Bertoldi, M., Bidlingmaier, W. and Stentiford, E. (eds.) *Compost science and technology*. Elsevier, Boston, MA, USA, p. 25-48.
- Jack, E.J. and Hepper, P.T. 1969. An outbreak of *Salmonella typhimurium* infection in cattle associated with the spreading of slurry. *Veterinary Record* 84: 196-199.
- Jensen, P., Recén, B. and Ekesbo, I., 1988. Preference of loose housed dairy cows for two different cubicles floor coverings. *Swedish Journal of Agricultural Research* 18: 141-146.
- Jørgensen, G.H.M., Andersen, I.L. and Bøe, K.E., 2007. Feed intake and social interactions in dairy goats – the effects of feeding, space and type of roughage. *Applied Animal Behaviour Science* 107: 239-251.
- Kearney, T.E., Larkin, M.J. and Levett, P.N., 1993. The effect of slurry storage and anaerobic-digestion on survival of pathogenic bacteria. *Journal of Applied Bacteriology* 74: 86-93.
- KilBride, A.L., Gillman, C.E. and Green, L.E., 2009. A cross-sectional study of the prevalence of lameness in finishing pigs, gilts and pregnant sows and associations with limb lesions and floor types on commercial farms in England. *Animal Welfare* 18: 215-224.
- KilBride, A.L., Gillman, C.E. and Green, L.E., 2010. A cross-sectional study of prevalence and risk factors for foot lesions and abnormal posture in lactating sows on commercial farms in England. *Animal Welfare* 19: 473-480.
- Kjæstad H.P. and Simensen E., 2001. Cubicle refusal and rearing accommodation as possible mastitis risk factors in cubicle-housed dairy heifers. *Acta Veterinaria Scandinavica* 42: 123-130.
- Lombard, J.E., Tucker, C.B., Von Keyserlingk, M.A.G., Kopral, C.A. and Weary, D.M., 2010. Associations between cow hygiene, hock injuries, and free stall usage on US dairy farms. *Journal of Dairy Science* 93: 4668-4676.

## I. Ekesbo

- Looper, M.L., Edrington, T.S. Callaway, T.R. and Rosenkrans Jr., C.F., 2009. Fate of *Escherichia coli* O157:H7 and *Salmonella* from contaminated manure slurry applied to soil surrounding tall fescue. *Letters in Applied Microbiology* 48: 513-516.
- Maule, A., 2000. Survival of verocytotoxigenic *Escherichia coli* O157 in soil, water and on surfaces. *Journal Applied Microbiology* 88: 71S-78S.
- Mohammed, H.O., Stipetic K., McDonough, P.L., Gonzalez, R.N., Nydam, D.V. and Atwill, E.R., 2009. Identification of potential on-farm sources of *Listeria monocytogenes* in herds of dairy cattle. *American Journal of Veterinary Research* 70: 383-388.
- Mootian, G., Wu, W.H. and Matthews, K.R., 2009. Transfer of *Escherichia coli* O157:H7 from soil, water, and manure contaminated with low numbers of the pathogen to lettuce plants. *Journal of Food Protection* 72: 2308-2312.
- Morales, A., Garza, A. and Sotomayor, J.C., 1997. Wild turkey's diet in Durango, Mexico. *Revista Chilena de Historia Natural* 70: 403-414
- Mukhejee, A., Speh, D. and Diez-Gonzalez, F., 2007. Association of farm management practices with risk of *Escherichia coli* contamination in pre-harvest produce grown in Minnesota and Wisconsin. *International Journal of Food Microbiology* 120: 296-302.
- Murphy, M.R., 1992. Water metabolism of dairy cattle, *Journal of Dairy Science* 75: 326-333.
- Natvig, E.E., Ingham, S.C., Ingham, B.H., Cooperband, L.R. and Roper, T.R., 2002. *Salmonella enterica* serovar Typhimurium and *Escherichia coli* contamination of root and leaf vegetables grown in soils with incorporated bovine manure. *Applied and Environmental Microbiology* 68: 2737-2744
- Norring, M., Manninen, E., De Passille A.M., Rushen, J. and Saloniemi, H., 2010. Preferences of dairy cows for three stall surface materials with small amounts of bedding. *Journal of Dairy Science* 93: 70-74.
- Olstorpe, M., Borling, J., Schnürer, J. and Passoth, V., 2010. *Pichia anomala* yeast improves feed hygiene during storage of moist crimped barley grain under Swedish farm conditions. *Animal Feed Science and Technology* 156(1-2): 47-56.
- Payne, J.H., Hogg, R.A., Otter, A., Roest, H.I.J. and Livesey C.T., 2011. Emergence of suspected type D botulism in ruminants in England and Wales (2001 to 2009), associated with exposure to broiler litter. *Veterinary Record* 168: 640-643.
- Peinhopf, W. and Deutz, A., 2005. Increased occurrence of acute mastitis caused by *Klebsiella* spp. in a dairy with sawdust bedding. *Praktische Tierarzt* 86: 420-422.
- Plym Forshell, L. and Ekesbo, I., 1993. Survival of *Salmonellas* in composted and not composted solid animal manure. *Journal of Veterinary Medicine B* 40: 654-658.
- Plym Forshell, L. and Ekesbo, I., 1996. Survival of *Salmonellas* in urine and dry faeces from cattle – an experimental study. *Acta Veterinaria Scandinavica* 37: 127-131.
- Plym Forshell, L., 1993. Composting of cattle and pig manure. *Journal of Veterinary Medicine B* 40: 634-640.
- Plym Forshell, L., 1996. Concerning *Salmonella* survival and animal wastes. *SLU Rapport* 39, 43 pp.
- Plym-Forshell, L. and Svedberg, J., 1981, Pelleted feed as a source of *salmonella* in poultry meat, *Proceedings World Association of Veterinary Food Hygienists, VIII international symposium, Dublin, Ireland.*
- Plym-Forshell, L., 1995. Survival of *Salmonella* and *Ascaris Suum* eggs in a thermophilic biogas plant. *Acta Veterinaria Scandinavica* 36: 79-85.
- Reich, L.J., Weary, D.M., Veira, D.M. and Von Keyserlingk, M.A.G., 2010. Effects of sawdust bedding dry matter on lying behavior of dairy cows: a dose-dependent response. *Journal of Dairy Science* 93: 1561-1565.

## 6. The impact of feeding, drinking, bedding and waste management

- Rhoades, J.R., Duffy, G. and Koutsoumanis, K., 2009. Prevalence and concentration of verocytotoxigenic *Escherichia coli*, *Salmonella enterica* and *Listeria monocytogenes* in the beef production chain: a review. *Food Microbiology* 26: 357-376.
- Roesicke, E. and Greuel, E., 1992. Survival of *Salmonella*, *Coccidia* oocysts and *Ascaris* eggs in manure of chicken in different kinds of housing systems. *Deutsche Tierärztliche Wochenschrift* 99: 492-494.
- Rouha-Müelleder, C., Iben, C., Wagner, E., Laaha, G., Troxler, J. and Waiblinger, S., 2009. Relative importance of factors influencing the prevalence of lameness in Austrian cubicle loose-housed dairy cows. *Preventive Veterinary Medicine* 92: 123-133.
- Rutherford, K.M.D., Langford, F.M., Jack, M.C., Sherwood, L. and Lawrence, A.B., 2008. Hock injury prevalence and associated risk factors on organic and nonorganic dairy farms in the United Kingdom. *Journal of Dairy Science* 91: 2265-2274.
- Ruud, L.E., Kielland, C., Østerås, O. and Bøe, K.E., 2011. Free-stall cleanliness is affected by stall design. *Livestock Science* 135: 265-273.
- Semenov, A.V., Van Overbeek, L. Termorshuizen, A.J. and Van Bruggen, A.H.C., 2011. Influence of aerobic and anaerobic conditions on survival of *Escherichia coli* O157:H7 and *Salmonella enterica* serovar *Typhimurium* in Luria-Bertani broth, farm-yard manure and slurry. *Journal of Environmental Management* 92(3): 780-787.
- Strauch, D. 1981. Hygienic aspects of storage and distribution of solid and liquid manure. *Tierzüchter* 33: 149-150.
- Unnerstad, H. E., Lindberg, A., Waller, K. P., Ekman, T., Artursson, K., Nilsson-Ost, M. and Bengtsson, B., 2009. Microbial aetiology of acute clinical mastitis and agent-specific risk factors. *Veterinary Microbiology* 137: 90-97.
- USDA, 2009. Info Sheet, APHIS Issue: N536.0109, 3 pp.
- Van Veen, H.M. Vellenga, L. and Hoogerbrugge, A., 1985. Mortality morbidity and external injuries in piglets housed in 2 different housing systems 2. rearing period of weaned piglets age 5.5-10 weeks. *Veterinary Quarterly* 7: 127-132.
- Voigt, Y., Georg, H. and Jahn-Falk, D., 2007. Evaluation of the preference for different free-stall bedding systems by dairy cows under field conditions. *Tierärztliche Umschau* 62: 531-536.
- Ward, P.L., Wohlt, J.E. and Katz, S.E., 2001. Chemical, physical, and environmental properties of pelleted newspaper compared to wheat straw and wood shavings as bedding for horses. *Journal of Animal Science* 79: 1359-1369.
- Ward, W.R., Hughes, J.W., Faull, W.B., Cripps, P.J., Sutherland, J.P., Sutherst J.E., 2002. Observational study of temperature, moisture, pH and bacteria in straw bedding, and faecal consistency, cleanliness and mastitis in cows in four dairy herds. *Veterinary Record* 151: 199-206.
- Wassmuth, R., Wallbaum, F. and Langholz, H.J., 1999. Outdoor wintering of suckler cows in low mountain ranges. *Livestock Production Science* 61: 193-200.
- Wechsler, B; Schaub, J; Friedli, K; Hauser, R, 2000. Behaviour and leg injuries in dairy cows kept in cubicle systems with straw bedding or soft lying mats. *Applied Animal Behaviour Science* 69: 189-197.
- Wekerle J, Mack H, Wehrle V, Strauch D., 1986, Chemical disinfection of pig slurry to eliminate Aujeszky Disease virus. *Tierärztliche Umschau* 41: 862-866.
- Whitaker, D.A., Kelly, J.M. and Smith, S., 2000. Disposal and disease rates in 340 British dairy herds. *Veterinary Record* 146: 363-367.



## 7. Factors influencing water temperature on farms and the effect of warm drinking water on pig growth

T. Banhazi<sup>1</sup> and D. Rutley<sup>2</sup>

<sup>1</sup>National Centre for Engineering in Agriculture (NCEA), University of Southern Queensland, West Street, Toowoomba, QLD 4530, Australia; <sup>2</sup>Livestock Systems Alliance, The University of Adelaide, Roseworthy Campus, SA 5371, Australia; [thomas.banhazi@usq.edu.au](mailto:thomas.banhazi@usq.edu.au)

### Abstract

Drinking water temperature was measured continuously for one year on 22 pig farms in South Australia (SA) and Queensland (QLD) and data were collected on major housing features and management factors employed in individual piggery buildings. The data collected enabled the likely effects of housing and management factors on resulting water temperature to be quantified and the industry to be made aware of the importance of providing drinking water within optimal temperature range for efficient pig production and welfare. The data collected identified statistically significant housing and management factors associated with and contributing to sub-optimal water temperature as seasons ( $P=0.0001$ ), source of water ( $P=0.0001$ ), position of piping ( $P=0.003$ ), water pressure ( $P=0.042$ ), size of in-shed water reservoir ( $P=0.0001$ ) and diameter of the main ( $P=0.0001$ ) and delivery pipes ( $P=0.0001$ ). A controlled experiment was also conducted to complement these findings by quantifying the negative effect of sub-optimal (warm) drinking water temperature on pig growth rate. Two identical weaner rooms were selected for the on-farm study. Genetics, nutrition, management, stocking rate and density were identical for both groups. Pigs in the treatment group received water heated to  $28.3\pm 0.4$  °C while the control group received unheated water at  $17.8\pm 0.9$  °C. Growth rate was suppressed by 58 grams/day in the group receiving the heated water. These results demonstrate the negative effect of warm water temperature on pig production and highlight potential ways of reducing the likelihood of providing warm drinking water to livestock.

**Keywords:** management, drinking water, thermal environment, temperature, growth rate

### 7.1 Introduction

The thermal environment of intensively housed pigs is predominantly influenced by air temperature, humidity and airspeed (Black *et al.*, 2001; Jones and Nicol, 1998; Le Dividich and Herpin, 1994; Zhang *et al.*, 1992). However, other factors such as the temperature of drinking water can also have a significant effect on how individual animals will be affected by the thermal conditions in the sheds (Brooks and Carpenter, 1990). It was hypothesised that warmer drinking water will discourage animals from drinking adequate water, in turn reducing their feed intake (Morrison *et al.*, 2007; Yang *et al.*, 1984) and growth. While no firm drinking water temperature recommendations exist for pigs, some studies suggest that cool drinking water may improve feed intake. Although, studies (Bigelow and Houpt, 1988; Van der Peet-Schwering *et al.*, 1997) indicate that water temperature might have a significant effect on water intake in pigs, the overall

effect of drinking water temperature on pig production has not been assessed under Australian farming conditions.

Therefore, this study was designed with a number of aims in mind. First, information on drinking water temperature and factors potentially influencing drinking water temperature were collected during the survey component of the project. This information enabled the research team to document the extent of sub-optimal drinking water temperature present in piggery buildings and to identify relationships between features of watering systems and drinking water temperature. Such information is not available in the literature currently. In addition a related on-farm experiment was designed to quantify production loss associated with sub-optimal drinking water temperature. Overall the study enabled researchers to develop strategies to optimise drinking water temperature for pigs in summer and winter by identifying practical ways of improving the thermal control of watering systems in commercial piggeries. As a result, it was hoped that the production efficiency and welfare of pigs could be improved.

## **7.2 Materials and methods**

### **7.2.1 Study farms**

Twenty-two farms were selected for the survey with 10 in Queensland (QLD) and 12 in South Australia (SA). On each farm, water temperature was monitored continuously for 12 months in one of the 4 buildings selected within the same farm. Farms in SA were located in the Northern, Central and Riverland regions to represent Mediterranean, cold temperate and warm temperate zones found in Western Australia, Victoria and Southern New South Wales (NSW). Farms in QLD were selected in the sub-tropical region representative of the northern NSW and Southern and Central QLD. The study sheds included a wide range of design and management options and sites were chosen to provide a representative sample of industry practice in Australia.

### **7.2.2 Measurement methods and location**

Temperature data were recorded in all study buildings using Tinytalk temperature loggers (Tinytalk-2, Hastings Data loggers Pty. Ltd., Port Macquarie, Australia). These self-contained and battery-powered data loggers with external sensors on a lead have the capacity to record temperature and humidity data for up to one year, depending on the pre-set logging interval (Banhazi *et al.*, 2008). A 72 minute logging interval was selected and standardised for the whole project, allowing the data loggers to run unattended for ninety days (3 months, a whole season). The choice of a 72-minute interval was a good compromise between obtaining an accurate environmental record and producing excessive redundant data. The external temperature leads of the sensors were inserted in the water pipes as close to the drinkers as practically possible, without allowing the pigs to interfere with the instruments. Care was taken to ensure the installed sensors did not impinge on the normal operation and management of the piggery.



## **7. Water temperature on farms and the effect of warm drinking water on pig growth**

### **7.2.3 On-farm experiment**

Two identical weaner rooms were selected for the second study. Genetics, nutrition and management were identical for both groups. Pigs were included in the experiment from weaning until approximately 25 kg or 10 weeks of age. Stocking rate was similar for both groups, the control group consisted of 93 pigs and the trial group consisted of 82 pigs. Pigs in the treatment group received water heated to  $28.3\pm 0.4$  °C while the control group received drinking water managed according to normal management practices without any heating or cooling (untreated) at  $17.8\pm 0.9$  °C. Large-capacity commercial aquarium heaters were used to heat the water in the water reservoir to the pre-set temperature (Fluval Aquarium Heater, Hagen Inc. Montreal, Canada). The temperature of the heated water was based on the preliminary analysis of field measurements and was the upper quartile of the summer water temperatures recorded on South Australian farms. Heaters were evaluated first under laboratory conditions, using a large water tank of identical size to the water tanks used for the subsequent on-farm trial. Growth rate was monitored in both the experimental and control groups using an electronic scale (Weigh Crate, Ruddweigh, Guyra, Australia).

### **7.2.4 Data handling**

A questionnaire was developed to collect information relating to the engineering features and setup of the watering systems used in individual buildings. Each farm received four one-day visits, corresponding with the four seasons. At each quarterly farm visit the data was extracted from the loggers and downloaded to a portable computer on site. The extracted data and the sensors were inspected during these visits to ensure the proper functioning of the loggers throughout the data collection period. For each logging site a form was filled out to record all installation details. After downloading, the data files were named using a standardised system, which enabled easy farm/shed/logging period identification.

In the most basic form of presentation, the temperature files were plotted against time. This was the most useful method of presenting data to producers so they could get an appreciation of the thermal performance of their watering systems. However, to make data processing more efficient separate Excel based software was developed facilitating easier data presentation and storage of the large amount of data collected. This software included the relevant mathematical equations to automatically compute the maximum/minimum and average values for water temperature for a given period. The percentage of time spent above, below and within the recommended water temperature range, 18-25 °C (Pointon *et al.*, 1995) was also automatically calculated. This basic analysis and graphical presentation of the data also served as a feedback report for participating producers. Observations, which were specific to a shed, were discussed with relevant producers at farm visits.

### **7.2.5 Statistical method**

Statistical models were developed to test the significance of various associations between measured variables. The response variable of interest was water temperature. Data was analysed using the SAS GLM procedure in order to explain as much of the variation in the response variable as



possible (SAS, 1989). The explanatory effects and covariates examined were seasons (summer, autumn, winter and spring), source of water (bore, river, main), position of piping (above or below ground), water pressure (high or low), size of in-shed water reservoir (more than 25 l, less or none) and diameter of both main and delivery pipes (mm). These effects were used to explain variations in water temperature in 12 South Australian sheds over the four seasons' average temperature records for the different seasons were considered to be independent. All main effects were tested, but only limited interactions could be tested, due to the limited number of sheds surveyed. The statistical models were developed from the maximum model tested by sequentially removing non-significant interactions and effects ( $P < 0.05$ , based on type III estimable functions) until only significant effects and interactions remained. For presentation of the results the least squares means ( $\pm$  standard error) have been estimated for factors and the equations of regressions have been calculated from the parameter estimates. This enabled consideration of a number of potentially important factors simultaneously, as opposed to single correlation analysis techniques (Chen and Chen, 1999; Demidenko and Stukel, 2002). Therefore, even watering systems with different characteristics could be analysed together and reliably compared with each other, as this statistical analysis ensures that the dataset is adjusted for such differences (SAS, 1989). Statistical modelling is an appropriate method of handling unbalanced field data in order to interpret the results reliably and sensibly.

The results of the on farm experiment were analysed using one-way ANOVA (StatSoft, 2001). Each pig was considered as a replicate to determine average daily gain.

### 7.3 Results and discussion

#### 7.3.1 Study component 1 – field survey: shed effects on water temperature

In Table 7.1, the mean water temperature values are presented together with time spent within and outside of the recommended temperature range (18-25 °C) for all buildings surveyed.

A great deal of deviation from optimal water temperatures can be observed in all buildings and all seasons. It can be argued that the optimal temperature range used for this study (18-25 °C), based on the recommendations of the 'Good Health Manual' (Pointon *et al.*, 1995), was very narrow.

Table 7.1. Descriptive statistics – average water temperatures and time spent within, above and below recommended ranges in the study buildings (SA=South Australian farms; QLD=Queensland farms).

	SA water temperatures (°C)				QLD water temperatures (°C)			
	Average	% in range	% below	% above	Average	% in range	% below	% above
Summer	23.41	68.37	3.10	28.53	24.96	59.94	0.23	39.82
Winter	13.72	9.08	90.11	0.82	16.17	27.40	72.58	0.01
Spring	19.00	56.45	38.58	4.97	21.71	79.59	8.99	11.42
Autumn	17.40	39.40	59.12	1.48	20.10	68.37	19.87	11.76

## 7. Water temperature on farms and the effect of warm drinking water on pig growth

However, this range was used to demonstrate the varied nature of measured water temperatures in different piggery buildings. Using these recommended ranges, the data demonstrated that different classes of pigs drink water only approximately 50% of the time within the recommended temperature ranges across all seasons. In Queensland pigs spend 15% of their time (40% in summer) drinking water above 25 °C; while in SA they spend nearly 50% of their time (90% in winter) drinking cold water. At other times of the year pigs spend between 20 to 60% of their time drinking water that is outside the optimal temperature range.

The details of the analysis are shown in Table 7.2, including the model  $R^2$  values. Only 11 degrees of freedom was used from the available total degrees of freedom, indicating the robustness of the model and the fact that the model is not over-parameterised. Several key factors affecting water temperature in piggery buildings were identified. The results of the analyses are summarized in Table 7.3.

Seven factors and covariates were identified as having a significant effect on water temperature in piggery buildings. These were season, source of water, position of piping, water pressure, size of in-shed water reservoir, diameter of main pipe and diameter of delivery pipes (Table 7.3 and Figures 7.1-7.6). In summer water temperatures were significantly higher than at other times of the year (Figure 7.1) and water from the main supply was warmer than bore or river water (Figure 7.2). Water supplied through pipes that were above ground (Figure 7.3) and high pressure pipes (Figure 7.4) had significantly higher temperature than water supplied using pipes that were buried underground with low pressure system, respectively. Watering systems that had water

Table 7.2. General linear model developed for assessing water temperatures.

Model parameter	
Model degrees of freedom	11
Corrected total degrees of freedom	47
Coefficient of determination ( $R^2$ %)	92

Table 7.3. Significance of effects associated with water temperature.

Effects and interactions	Water temperatures
Seasons (summer, autumn, winter, spring)	$P=0.0001$
Source of water (bore, main, river)	$P=0.0001$
Position of piping (above or below ground)	$P=0.0027$
Water pressure (high or low)	$P=0.0425$
Size of in-shed water reservoir (none, more than 25 l or less)	$P=0.0001$
Diameter of main pipe (mm)	$P=0.0001$
Diameter of delivery pipe (mm)	$P=0.0001$

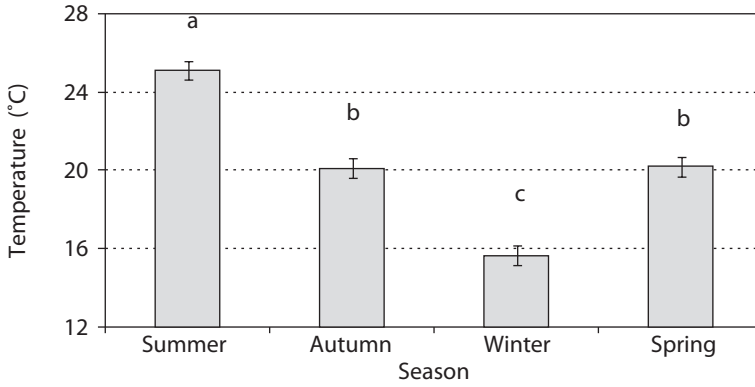

Figure 7.1. Effect of season on water temperatures (least squares mean  $\pm$  standard error). Groups with a different letter are significantly different at  $P=0.0001$ .

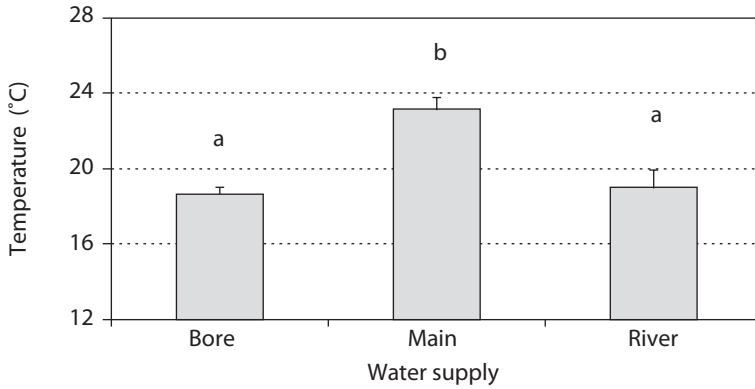

Figure 7.2. Effect of water supply on water temperature (least squares mean  $\pm$  standard error). Groups with a different letter are significantly different at  $P=0.0001$ .

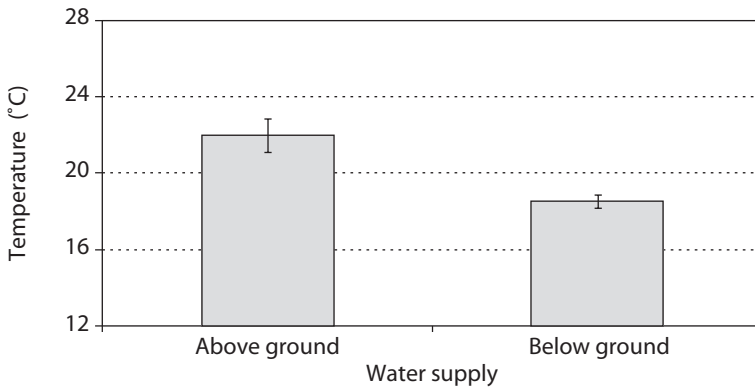

Figure 7.3. Effect of above or below ground water supply on water temperature (least squares mean  $\pm$  standard error) ( $P=0.0027$ ).

## 7. Water temperature on farms and the effect of warm drinking water on pig growth

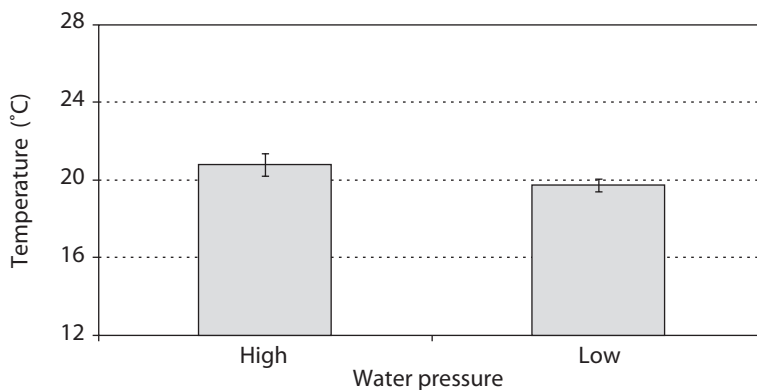

Figure 7.4. Effect of water pressure on water temperature (least squares mean  $\pm$  standard error) ( $P=0.0425$ ).

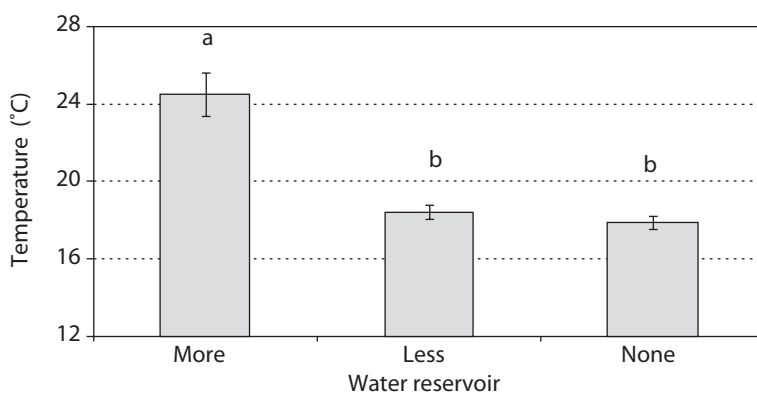

Figure 7.5. Effect of water reservoir on water temperature (least squares mean  $\pm$  standard error). Groups with a different letter are significantly different at  $P=0.0001$ . Water reservoirs size were classified as: more = more than 25 litres, less = less than 25 litres, none = no water reservoirs were present in these buildings

reservoirs larger than 25 litres recorded higher temperature (Figure 7.5), while water temperature was positively correlated with the diameter of both the main and delivery pipes (Figure 7.6). As expected, good common sense recommendations were developed based on the project results.

There was a clear seasonal variation identified in drinking water temperatures (Figure 7.1). As expected, summer water temperatures (25.1 °C) were significantly higher than water temperatures recorded in any other seasons. Spring (20.2 °C) and autumn (20.1 °C) mean temperatures were very similar, while mean winter water temperatures (15.6 °C) were significantly colder than water temperatures recorded during any other season. The reason for this is obvious and highlighted the need for the producers to be aware of the increased risk of sub-optimal water temperatures occurring during summer. Pig producers need to put an extra emphasis on regularly monitoring drinking water temperatures during the summer months and implement management strategies to counteract the potentially negative effects of sub-optimal water temperatures during this time of the year.

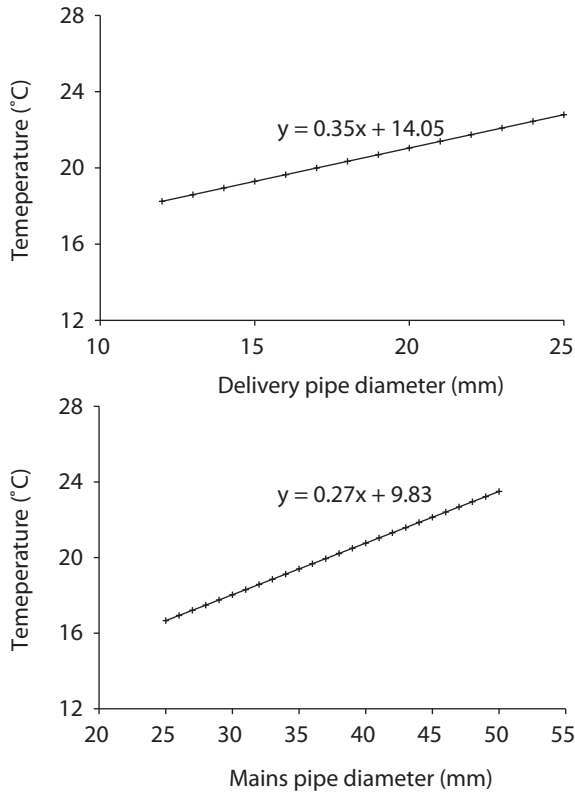

Figure 7.6. Effect of delivery (bottom) and main (top) pipe diameters on water temperature (P=0.0001).

Bore (18.6 °C) and river water (19.0 °C) is generally cooler than the main water (23.1 °C) supply (Figure 7.2). Using bore or river water can obviously assist producers to reduce water temperatures in piggery buildings and potentially capture the production benefits associated with optimal water temperatures.

Using water pipes that are buried below ground (18.5 °C) could be used effectively to keep drinking water colder (Figure 7.3) than water supplied via above ground pipes (22.0 °C). As a matter of fact approximately 3.5 °C temperature reduction can be achieved in water temperature by simply burying water pipes below ground. This 3.5 °C reduction is quite large and could potentially encourage pigs to increase their water intake. Increased water intake would be expected to lead to increased feed intake, resulting in growth rate and efficiency improvements (Bigelow and Houpt, 1988; Yang *et al.*, 1984).

Low-pressure systems had lower drinking water temperatures (19.7 °C) than high water pressure (20.8 °C) systems (Figure 7.4). It is difficult to explain why low pressure systems result in reduced water temperatures. This effect is independent of the effect of the main supply running at higher pressure and so the explanation for this could lie in the natural physical relationship between

## 7. Water temperature on farms and the effect of warm drinking water on pig growth

temperature and pressure. High-pressure systems are usually associated with main water supplies and drinking systems being fed from main water supplies tend to have higher water temperatures.

According to the results (Figure 7.5), drinking water systems that had in-shed reservoirs over 25 litres recorded significantly higher water temperature (24.5 °C) than drinking water systems that had smaller reservoirs (18.4 °C) or no reservoir (17.9 °C). However, this may be due to the quality of water storage facilities (i.e. uninsulated and in bad repair) rather than the existence and/or the size of water reservoirs. It is expected that poorly designed and maintained water reservoirs would increase drinking water temperature.

Drinking water temperature was positively correlated with the diameter of both the mains and smaller delivery pipes. The positive effect of pipe diameter on drinking water temperatures might be a combination of many factors. However, the most likely explanation is that the larger pipes do absorb heat faster than smaller pipes, due to the larger surface exposed to hot air or direct sunlight. In addition, the speed of water flow is higher in smaller pipes; hence the water has less opportunity to absorb heat. Further studies are needed to better understand this effect.

In summary, the main effects on drinking water temperature in piggery buildings were season, source of water, position of piping, water pressure, size of in-shed water reservoir and diameter of main pipe and delivery pipes. In summer water temperature was significantly higher than at other times of the year and this highlighted the need for the producers to be aware of the increased risk of sub-optimal water temperature occurring during summer. Drinking water sourced from the main supply was warmer than drinking water sourced from bore or river water. Obviously manipulating or changing the source of drinking water is very difficult, if not impossible, but producers need to be aware of the potential effects of the water source on the likely temperature of drinking water supplied to pigs. Water supplied in high pressure pipes and supplied in pipes that were above ground had significantly higher temperature than drinking water supplied with low pressure system and from pipes that were buried underground, respectively. It is not obvious why low pressure systems result in reduced water temperatures, but is possible that the physics of the positive relationship between pressure and temperature at constant volume is the cause. Watering systems that had water reservoirs larger than 25 litres recorded higher drinking water temperatures. This may be due to the quality of water storage facilities (i.e. uninsulated and in bad repair) rather than the existence and/or the size of water reservoirs, as poorly designed and maintained water reservoirs obviously tend to increase drinking water temperatures. Thus producers do need to ensure that in-shed water reservoirs are maintained regularly and kept in good working order, including adequate insulation. Drinking water temperature was positively correlated with the diameter of both the main and smaller delivery pipes. The most likely explanation is that the larger pipes do absorb heat faster than smaller pipes, due to the larger surface exposed to hot air or direct sunlight. In addition, the speed of water flow is higher in smaller pipes; hence the water has less opportunity to absorb heat. However, manipulation of all these factors will require careful consideration.

No previously published articles have been found by the authors of this chapter that would identify the statistically significant factors influencing drinking water temperatures in piggery

buildings. Thus this study results would have significant impact on current knowledge related to the appropriate management of drinking systems on farms.

### 7.3.2 Study component 2 – on-farm experiment: effect of water temperature on pig growth rate

The experimental component of the study was conducted at the University of Adelaide, Roseworthy campus research piggery. A preliminary study before the actual experiment confirmed that the aquarium heaters (Fluval Aquarium Heater, Hagen Inc. Montreal, Canada) selected for water temperature control were simple to install, cost effective and easy to maintain. The heaters were capable of achieving good control of water temperature within a very narrow temperature range ( $28.5 \pm 0.4$  °C), which was quite independent of surrounding air temperatures ( $21.5 \pm 0.9$  °C). There was a close association between the temperature of water in the overhead tank ( $28.6 \pm 0.4$  °C) and that supplied to the pigs under experimental conditions ( $28.16 \pm 0.45$  °C). The results of this preliminary equipment trial demonstrated that the water temperature in the tanks and supplied to the animals was well controlled.

Figure 7.7 shows the water and air temperatures in the experimental and control rooms over a 12 day period, as an example. The average air temperature for the treatment group was  $21.8 \pm 0.7$  °C and  $21.4 \pm 0.8$  °C for the control group for the duration of the trial. Pigs in the treatment group received water heated to  $28.4 \pm 0.4$  °C, while the control group received unheated water at an average temperature of  $17.8 \pm 0.9$  °C.

The growth rates of experimental and control pigs are shown in Figure 7.8. Growth rate was suppressed ( $P < 0.05$ ) by 58 grams/day in the group receiving the heated water. This was a reduction of 17% of the daily growth rate.

This experiment demonstrated the significantly adverse effect of warm drinking water. Based on the assumption that this lost growth would be equivalent for weaner pigs in this shed throughout the year, the loss of 58 grams per day would equate to a loss of 15.9 kg. At \$3.00 per kg carcass

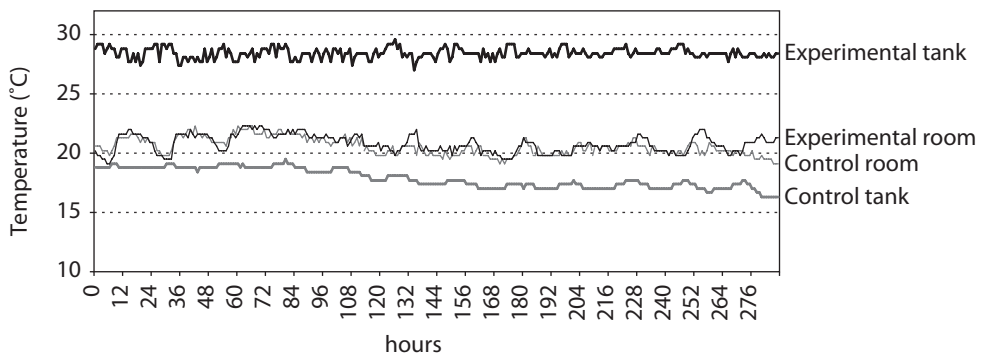

Figure 7.7. Water and air temperatures in the control and experimental rooms.

## 7. Water temperature on farms and the effect of warm drinking water on pig growth

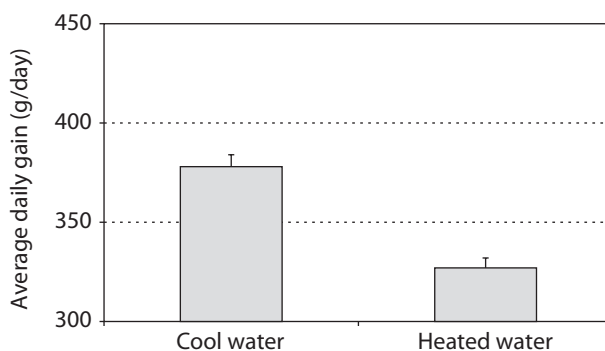

Figure 7.8. Average daily gain for the weaner pigs supplied with heated and unheated water (mean  $\pm$  SE).

weight with a 75% dressing per cent this would cost from \$45 to \$50 per weaner capacity in the shed. If we acknowledge that the average summer temperature of drinking water in QLD was 25 °C, the 7 °C increase in water temperature for ¼ of the year, assuming a linear response as temperature increases, would equate to a loss of \$8 per weaner space in the shed, \$8,000 per shed per year for a 1000 head weaner shed.

Although losses under commercial conditions may not be as large as calculated above, producers should be aware of the potentially harmful effects of sub-optimal drinking water temperatures. It is important to note that during this study a very stable and relatively warm drinking water temperature was achieved. In commercial conditions there is usually larger daily temperature variation, allowing pigs to modify drinking behaviour and consume water during the cool parts of the day, mitigating the relatively large difference in growth rate found in this experiment. However, it is also important to note that this growth rate reduction was demonstrated with optimal ambient air temperature in conjunction with warm drinking water.

Limited amount of previously published papers were identified in the literature that would discuss the effects of water temperatures on growth rates in pigs. However, the few articles that were identified essentially supported the results of this current study (Brew *et al.*, 2011; Jeon *et al.*, 2006; Kruse *et al.*, 2011). For example, a study conducted on the water intake of sows demonstrated a negative relationship between water intake and relative body weight loss of sows expressed as a percentage of original body weight (Kruse *et al.*, 2011). Another study demonstrated that sows drinking either 10 °C or 15 °C water had significantly higher water and feed intake rates than sows drinking water at the temperature of 22 °C resulting in higher estimated milk production rates (Jeon *et al.*, 2006). These studies therefore indirectly confirmed the results of the current study indicating a link between (1) increased water intakes and production rates as well as linking (2) drinking water temperatures and water consumption rates. Water has been regarded by many as a 'neglected nutrient' in pig production and the management of drinking water is obviously an important aspect of good farm management practices (Brooks and Carpenter, 1990). This chapter suggested ways of reducing the impact of sub-optimal drinking water temperatures on pig growth



by implementing a few simple construction and management principles in relation to watering systems installed on pig farms.

## **7.4 Conclusions**

As a result of this research the understanding of factors affecting drinking water temperature in piggery buildings has improved. In addition, the likely effect of warm drinking water temperature on growth was quantified.

Factors identified to be affecting drinking water temperature in piggery buildings included season, source of water, position of piping, water pressure, size of in-shed water reservoir and diameter of main and delivery pipes. Careful management of these factors could aid the provision of optimal drinking water temperature and enhance growth throughout the year.

Under experimental conditions approximately 10 °C water temperature increase resulted in 58 g/day growth rate reduction. Although it was recognised that under commercial conditions the production efficiency loss might not be that significant, producers should be aware of the importance and magnitude of the losses from not providing drinking water to pigs within the optimal temperature range.

## **Acknowledgements**

We wish to acknowledge the financial support of the Pig Research and Development Corporation (PRDC) and the important contribution of producers (including the project partner, CEFN Pty. Ltd.), their managers and staff who kindly donated their time and facilities. We would also like to thank Dr C. Cargill (South Australian Research and Development Institute, SARDI), who was instrumental in obtaining funding for the project; Prof John Black, (J. Black Consulting) and Prof J. Hartung (Hannover University, Germany) for their professional advice. The important contribution of Mr J. Weigel of SARDI involved in the study is also gratefully acknowledged.

## **References**

- Banhazi, T.M., Seedorf, J., Rutley, D.L. and Pitchford, W.S., 2008. Identification of risk factors for sub-optimal housing conditions in Australian piggeries – Part II: airborne pollutants. *Journal of Agricultural Safety and Health* 14: 21-39.
- Bigelow, J.A. and Houpt, T.R., 1988. Feeding and drinking patterns in young pigs. *Physiology & Behavior* 43: 99-109.
- Black, J.L., Giles, L.R., Wynn, P.C., Knowles, A.G., Kerr, C.A., Jone, M.R., Gallagher, N.L. and Eamens, G.J., 2001. A review – factors limiting the performance of growing pigs in commercial environments. In: Cranwell, P.D. (ed.) *Manipulating pig production VIII*. Australasian Pig Science Association, Victorian Institute of Animal Science, Werribee, Victoria, Australia, pp. 9-36.
- Brew, M.N., Myer, R.O., Hersom, M.J., Carter, J.N., Elzo, M.A., Hansen, G.R. and Riley, D.G., 2011. Water intake and factors affecting water intake of growing beef cattle. *Livestock Science* 140: 297-300.

## 7. Water temperature on farms and the effect of warm drinking water on pig growth

- Brooks, P.H. and Carpenter, J.L., 1990. The water requirement of growing-finishing pigs: Theoretical and practical considerations. In: Haresign, W. and Cole, D.J.A. (eds.) Recent advances in animal nutrition. Butterworths, Boston, MA, USA, pp. 115-136.
- Chen, Y.-H. and Chen, H., 1999. Incomplete covariates data in generalized linear models. *Journal of Statistical Planning and Inference* 79: 247-258.
- Demidenko, E. and Stukel, T.A., 2002. Efficient estimation of general linear mixed effects models. *Journal of Statistical Planning and Inference* 104: 197-219.
- Jeon, J.H., Yeon, S.C., Choi, Y.H., Min, W., Kim, S., Kim, P.J. and Chang, H.H., 2006. Effects of chilled drinking water on the performance of lactating sows and their litters during high ambient temperatures under farm conditions. *Livestock Science* 105: 86-93.
- Jones, R. and Nicol, C.J., 1998. A note on the effect of control of the thermal environment on the well-being of growing pigs. *Applied Animal Behaviour Science* 60: 1-9.
- Kruse, S., Traulsen, I. and Krieter, J., 2011. Analysis of water, feed intake and performance of lactating sows. *Livestock Science* 135: 177-183.
- Le Dividich, J. and Herpin, P., 1994. Effects of climatic conditions on the performance, metabolism and health status of weaned piglets: a review. *Livestock Production Science* 38: 79-90.
- Morrison, R.S., Smith, C.A. and Argent, C.D., 2007. The effect of cooled drinking water on the lactation performance of gilts and parity 1 sows. In: Paterson, J.E. and Baker, J.A. (eds.) *Manipulating pig production XI*. APSA, Werribee, VIC, Australia, pp. 37.
- Pointon, A.M., Cargill, C.F. and Slade, J., 1995. *The good health manual for pigs*. Pig Research and Development Corporation, Canberra, Australia.
- SAS, 1989. *SAS/STAT® User's Guide, Version 6, Fourth Edition, Volume 2*. SAS Institute, Cary, NC, USA.
- StatSoft, I., 2001. *STATISTICA*. StatSoft, Inc., Tulsa, OK, USA.
- Van der Peet-Schwering, C.M.C., Vermeer, H.M. and Beurskens-Voermans, M.P., 1997. Voluntary and restricted water intake of pregnant sows. In: Bottcher, R.W. and Hoff, S.J. (eds.) *5<sup>th</sup> International Symposium – Livestock Environment V*, 29-31 May 1997, Bloomington, MN, USA. American Society of Agricultural Engineers, pp. 959-964.
- Yang, T.S., Price, M.A. and Aherne, F.X., 1984. The effect of level of feeding on water turnover in growing pigs. *Applied Animal Behaviour Science* 12: 103-109.
- Zhang, Y., Barber, E.M. and Sokhansanj, S., 1992. A model of the dynamic thermal environment in livestock buildings. *Journal of Agricultural Engineering Research* 53: 103-122.



## 8. Eco-friendly and efficient management of solid animal manure

S.G. Sommer

University of Southern Denmark (SDU), Faculty of Engineering, Inst. of Chemical Eng.,  
Biotechnology and Environmental Tech., Campusvej 55, 5230 Odense M, Denmark;  
[sgs@kbm.sdu.dk](mailto:sgs@kbm.sdu.dk)

### Abstract

Manure has for centuries been used as a fertilizer to grasslands and for crop production in most farming systems. Unfortunately, poorly managed recycling of manure to land poses an environmental risk especially due to the content of nitrogen (N), organic carbon (C) and water – components that are substrates for the microbial production of the two greenhouse gases, nitrous oxide (N<sub>2</sub>O) and methane (CH<sub>4</sub>), and also for the pollutant ammonia (NH<sub>3</sub>) that is a risk to oligotrophic ecosystems and to human health. The two greenhouse gases may be produced and released from each stage of the manure management chain, which are: (1) livestock building/beef feedlots; (2) manure stores; (3) manure treatment; and (4) manure application to land. Management of the manure can greatly affect the emission of these gases through control of environmental parameters (temperature and water availability) and the removal of carbon. This chapter presents the processes involved in the production and emission of these gases, of the emission rates and how these are affected by manure management, and finally it gives examples of management chains that cause high and low releases of the gases to the atmosphere.

**Keywords:** greenhouse gas, ammonia, nitrogen, water, carbon, environment, management chain

### 8.1 Introduction

Animal manure is collected from animal houses, feedlots and exercise areas in a solid form or as a liquid. From the site of collection the manure has to be removed to an intermediate storage area or to its final end-use destination. Its end use will often be the application to fields or fish ponds, but the manure can also be used for energy production in biogas plants or incinerators.

The rationale for resorting to a management regime for the manure differs from country to country because of their different climates and farming traditions. Removing manure from animal houses reduces the spread of disease between individual animals and between stocks of animals, which is important in, for example, dairy cow, beef, poultry and pig productions (Burton and Turner, 2003). Manure is also removed frequently from animal houses to reduce ammonia, odour and greenhouse gas emissions, for example in tied animal houses. Manure is stored in the animal house or outside to facilitate the timing of the field application of the manure with crop need. Manure is also stored to ensure that manure treatment facilities downstream of the manure production receive an even and manageable load and avoid effect of the pulses of manure coming from emptying animal houses at daily, weekly or monthly intervals.

The amounts of manure produced on medium and large-scale animal farms are enormous. A dairy farm with 50 cows may produce 495 Mg farmyard manure (FYM) and 740 Mg deep litter

annually. For the manager, the transport of manure both out of animal houses, to fields or to other end uses is an operation that requires much manpower and heavy and large machinery. Thus, good forward planning of logistics is essential to reduce the time spent on transport and consequently the costs involved. Manure transport is also an element of annoyance to neighbours to the farms because of the noise generated and the large machines that end up driving on small country lanes, constituting a hazard to other road users. Finally, the excessive use of heavy machinery in the field causes soil compaction which has impacts on soil structure and fertility.

When managing animal manure one must bear in mind that manure contains significant amounts of carbon and plant nutrients that can be the precursors of greenhouse gases (GHG), pollution of surface waters, offensive odour, and ammonia emissions (Sutton *et al.*, 2011, Sommer *et al.*, 2009; Steinfeld *et al.*, 2006). However, the same plant nutrients can also be a valuable resource, and failing to make use of this will become increasingly unacceptable. Phosphorus is, for example, a mineral resource in dwindling supply, as mineable phosphate-rich rocks used for P-fertilizer production are projected to become exhausted within the next 60-130 years (Steen, 1998). Manure organic matter is another valuable resource that can be used in renewable energy production. Extensive EU and UN directives are addressing the associated pollution risks (EU Nitrates Directive, Water Framework Directive, National Emission Ceilings Directive, UN Convention on Transboundary Air Pollution). National regulations often tie in the reduction of pollution with the efficient recycling and use of manure.

Thus the challenge is to develop a management system for solid manure that is eco-friendly, resource-efficient and at the same time economically sustainable. This requires an understanding of solid manure characteristic and the microbial transformation processes that affect solid manure quality (pathogens, weed seed) and gas emissions. This is the objective of this chapter which covers animal housing systems, manure management chains and their related gas emissions.

## **8.2 Solid manure characteristics**

Solid manure is defined as manure that can be stacked and has a dry matter (DM) content of more than 10-15% (Table 8.1). The solid manure is collected in animal houses either in separate liquid and solid fractions or as a mixture containing a large amount of bedding material where the liquid has been absorbed by the straw.

In housing systems with livestock tied in stalls and with a solid straw-covered floor, the animals excrete on a gutter behind the resting area. In these systems the liquid drains away to a storage tank and the solid manure is often scraped off the floor, which produces a solid manure (farmyard manure; FYM) mainly containing faeces and straw.

In loose housing systems, straw, sawdust, peat or similar is spread on the floor to produce a deep litter mat, which may reach depths of up to 1-2 m. Faeces and urine are deposited in the deep litter, which has a very high DM content. In cattle houses the deep litter is compacted, giving it a high density, whereas it tends to be porous in pig houses because of the nesting and rooting behaviour of pigs.

## 8. Eco-friendly and efficient management of solid animal manure

Table 8.1. Typical composition of solid animal manures (Sommer and Hutchings, 2001; Sommer et al., 2004).

Manure	Animal	DM <sup>1</sup> g/kg	N-tot	TAN <sup>1</sup>	Ureic acid-N	P	K	pH
Solid manure	Cattle	182	4.85	1.33		1.45	3.85	7.80
	Pig	222	10.45	4.40		3.70	5.25	7.70
	Poultry	575	29.60	5.49	6.0	5.98	6.53	8.50
Deep litter	Cattle	261	5.20	0.90		1.40	9.70	8.60
	Pig	412	11.20	2.80				8.90
	Poultry	570	27.10	6.48	7.54	9.25	15.50	9.1
Litter feedlot	Beef	448	22.4	0.7				

<sup>1</sup> DM = (manure) dry matter; TAN = total ammoniac nitrogen.

Poultry may be housed in loose housing systems where droppings are collected on the floor, which is given a light covering of straw, woodchips or sand. Poultry are also housed in caged systems. Here the droppings are either stored below the cages or collected onto a conveyor belt below the cages. The DM content of solid poultry manure may vary between 31-67%. The variation in DM content of the solid manure is probably caused by drying, litter and drinking water spilling onto the manure (Kroodsma *et al.*, 1988).

In countries or regions with a high livestock production relative to field area, the manure may be removed from the animal house as slurry and then separated into a liquid fraction intended for on-farm usage or for further treatment and a DM and nutrient-rich fraction. The DM-rich fraction is retained in the separator – termed the retentate by engineers, while most farm managers just call it the solid fraction. The composition of the DM-rich fraction depends on the machine used to separate the slurry and on the composition of the slurry being treated (Hjorth *et al.*, 2010).

In Australia and the USA, the solid manure collected from beef feedlot systems has little or no straw bedding. These systems dominate in dry regions and the solid manure produced has a high DM content.

### 8.3 Transformation of organic matter

Carbon, nitrogen (N) and plant nutrients in the solid manure come from the faeces, urine and in the litter strewn on the floor. The nitrogen is added in many forms, as organic compounds, as urea and as other low-molecular-weight organic compounds in urine, or as more complex organic compounds in faeces, bedding and spilt animal feed. C is mostly present as organic components that are either easily digestible such as carbohydrates or slowly digestible such as lignocellulose. The C and N compounds in urine decompose rapidly, primarily via enzyme-promoted hydrolysis, resulting in the formation of CO<sub>2</sub> and ammonium (total ammoniac nitrogen, TAN=NH<sub>3</sub>+NH<sub>4</sub><sup>+</sup>). The decomposition of the more complex organic compounds is a slower process based on

microbial degradation and results in the formation of microbial biomass and in  $\text{CH}_4$ ,  $\text{H}_2\text{O}$ ,  $\text{CO}_2$  and  $\text{NH}_4^+$ .

Poultry manure differs from other animal categories because the TAN in poultry manure originates mainly from decomposed ureic acid in the droppings, i.e. no urine is produced. Ureic acid is a heterocyclic nitrogen compound, which slowly hydrolyses to urea, which then is further hydrolysed to TAN. The hydrolysis of ureic acid is slow and is affected by storage conditions, so the concentration of TAN and ureic acid will often be more variable than for other manures (Kroodsma *et al.*, 1988).

Nitrous oxide can be produced both in the nitrification and in the denitrification processes. Ammonium produced through mineralisation of urea and organic N is transformed by microorganisms to nitrate ( $\text{NO}_3^-$ ) in a process that involves the formation of nitrite ( $\text{NO}_2^-$ ) and nitrous oxide ( $\text{N}_2\text{O}$ ) as an intermediate compound. If the concentration of oxygen is low, a proportion of the  $\text{NO}_3^-$  can be transformed and emitted as nitrous oxide ( $\text{N}_2\text{O}$ ). Nitrous oxide is sparingly soluble in water and most is released to the atmosphere. If nitrification at an aerobic site in the manure proceeds fully to nitrate ( $\text{NO}_3^-$ ) and the  $\text{NO}_3^-$  is transported by diffusion to an anaerobic site, then microorganisms will use the  $\text{NO}_3^-$  as an oxygen source and denitrification may take place, which again involves the production of  $\text{N}_2\text{O}$  as an intermediate compound that may accumulate and be released to the atmosphere.

The oxygen concentration in the solid manure will affect the transformation process significantly. Where aerobic conditions are present, the organic matter is transformed by an oxidation processes that is exothermal. As a consequence, the transformation increases the temperature of the solid manure heap (Figure 8.1). If the stored solid manure is compacted, then the oxygen supply will be limited and in more sites of the heap the transformation processes will be anaerobic, consequently, the temperature of the manure will not rise as much as in the untreated manure heaps.

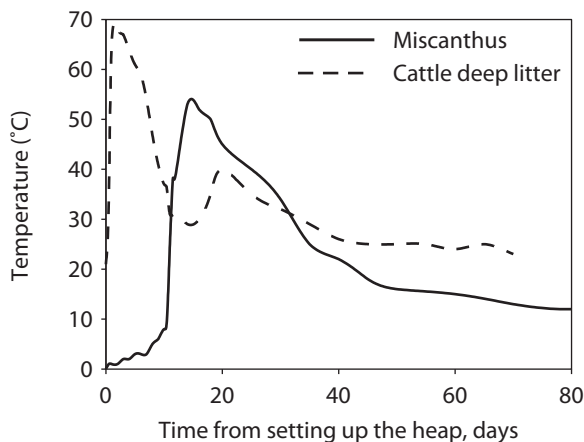

Figure 8.1. Temperature increase in stored solid manure heap and a heap of miscanthus.

## 8. Eco-friendly and efficient management of solid animal manure

### 8.3.1 Deep litter – animal houses

In animal houses with deep litter the air exchange may be affected by animal behaviour. The hoofs of housed cattle will compact the deep litter, whereas pigs on deep litter will tend to spread the bedding material. Aerobic microbial activity in cattle deep litter may cause an increase in temperature to 40-50 °C at a depth of about 10 cm. The air entering this layer in the mat is oxygen-depleted and below approx. 10 cm the litter becomes anaerobic and the temperature does not increase. In pig deep litter air transport is not constrained by compaction and one may assume the temperature may be high throughout the deep litter mat, but we have no data to confirm this hypothesis.

### 8.3.2 Composting solid manure

Solid manure stacked in a heap of a highly porous, air-filled nature is mostly aerobic. In an aerobic heap microbial transformation may be defined by the following four phases of transformation: initial (lag), thermophilic, mesophilic and curing phase.

The initial phase is marked by apparent inactivity where microorganisms adapt to the environment and the biomass. This can be very short if the organic matter is easily degradable and contains a large population of micro-organisms, or may be of longer duration if the organic matter is lignified as with elephant grass (Figure 8.1) or woodchips. This is because the lignified biomass has to be hydrolysed before a significant microbial transformation of the organic material can take place.

In the thermophilic phase the temperature increases to between 60 and 70 °C (Figure 8.1). This increase in temperature is due to the rapid degradation of organic matter by heterotrophic organisms. Such microorganisms gain their energy from the oxidation of organic compounds to CO<sub>2</sub> and H<sub>2</sub>O. The high-temperature thermophilic phase will often be of relatively short duration because the microorganisms die due to the high temperature and because the transport of O<sub>2</sub> to the interior of the heap is too slow to replenish the oxygen consumed by the aerobic microorganisms. Consequently, the temperature in the centre of the heap will be relatively low due to a reduction in the rate of the aerobic transformation of organic matter. Often the heaps are mixed or aerated to facilitate transport of O<sub>2</sub> into the heap and to prolong the thermophilic phase, giving a longer period with a high temperature so that pathogens can be killed (Table 8.2).

In the subsequent mesophilic phase the temperature slowly declines over a period of 20-30 days to about 20-35 °C. Very often a second increase in temperature of about 5-10 °C is seen during this phase (Figure 8.1, cattle deep litter). This increase in heaps not being turned or aerated is related to the growth of actinomyces (group of bacteria) and fungi; these microorganisms use cellulose and hemicellulose as their substrate, but they are not active at the high temperatures in the thermophilic phase.

After the mesophilic phase the temperature declines to the ambient temperature in the curing phase. This decline is usually due to exhaustion of the more easily digestible organic components in the biomass.



Table 8.2. Effect of sampling day on mean microbial counts ( $\log_{10}$  cfu/g) in pig manure-derived compost (McCarthy et al., 2011).

	Day					
	0	7	14	21	28	56
<i>Escherichia coli</i>	4.12 <sup>a</sup>	2.91 <sup>b</sup>	2.00 <sup>c</sup>	2.05 <sup>c</sup>	2.00 <sup>c</sup>	2.00 <sup>c</sup>
Coliform	5.34 <sup>a</sup>	4.24 <sup>b</sup>	4.55 <sup>b</sup>	4.54 <sup>b</sup>	4.65 <sup>b</sup>	4.43 <sup>b</sup>
<i>Enterococcus</i>	4.26 <sup>a</sup>	2.00 <sup>b</sup>	2.18 <sup>b</sup>	2.13 <sup>b</sup>	2.11 <sup>b</sup>	2.00 <sup>b</sup>
Yeast and moulds	4.32 <sup>a</sup>	3.68 <sup>a</sup>	4.86 <sup>ab</sup>	4.50 <sup>ab</sup>	4.80 <sup>ab</sup>	5.20 <sup>b</sup>
Spore-formers	5.10 <sup>a</sup>	5.73 <sup>ab</sup>	6.32 <sup>b</sup>	5.58 <sup>ab</sup>	5.88 <sup>b</sup>	6.07 <sup>b</sup>

Values within rows that do not share a common superscript are significantly different ( $P < 0.05$ ).

If the heap is not actively aerated or turned frequently, then the aerobic decomposition of organic matter will be affected by the pattern of airflow in the heap. The transport of air into the heap is strongly related to the air-filled space within the heap, which is related to the water content and density of the biomass (Poulsen and Moldrup, 2007). Thus,  $O_2$  concentrations will be low in heaps that have a high density or high water content. In these heaps transformation of organic matter may be anaerobic. Compacted heaps or heaps with high water content will thus be relatively cold as shown in Figure 8.2 where the increased density of the heap is caused by compaction and by high water content.

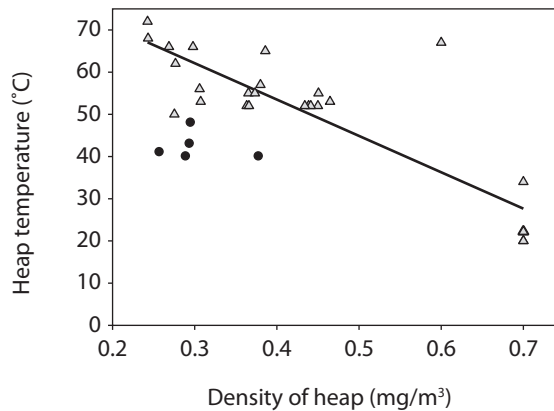

Figure 8.2. Temperature in manure heap as affected by manure density. The circles are data from stores covered with air-impermeable material (adapted from Webb et al., 2012).

### 8.4 Removal of solid manure from animal houses

In cattle houses solid manure may be collected through the regular scraping of the solid floor, either mechanically by a tractor (with a front or rear scraper or chain scrapers), or manually, or by a cable-drawn scraper blade. In these systems the liquid part of the manure drains off the floor through gutters and moves by gravity through tubes or channels to a store, which is often below soil surface. Sand may be spread on the floor to reduce sliding when the animals are walking.

Deep litter is produced in houses where cereal straw and other organic absorbent materials are spread on the floor (Table 8.3). The amount of litter used is variable as it depends on farm management practice and housing design. On fully covered floors all excreta are absorbed by the litter. Alternatively, some houses are designed with a combination of solid floors (with bedding material) and slurry channels where some of the urine and faeces is collected. In the latter houses the channels are situated below the walkways or near the eating places to enable collection of most of the excreta.

Solid manure with a high straw content may be removed on a daily basis in houses with sloping solid floors. The floor has a covering of straw that slowly slides down to a collection channel with low walls. From this channel the solid manure may be removed manually or with front loaders and deposited on a manure heap. The manure may also be transported on conveyor belts or scraped off to conveyors that transport the manure to the top of the manure heap. Alternatively, the conveyor belt may transfer the solid manure to a screw transporter below the heap. The screw transporter is encapsulated in a pipe so that the manure can be pushed up at the bottom of the

Table 8.3. Examples of deep litter management systems (Webb et al., 2012).

	Amount of straw	Area of surface with litter	Type of litter	Removal
Dairy	1,250 to 3,500 kg per year	60 to 85%	long straw, chopped straw	at 3 to 12-month intervals
Beef (live weight 200-640 kg)	no data	100%	long straw	after each group of animals
Fattening pigs (live weight 18-55 kg or 90-146 kg)	36-395 kg per year per place	25 to 100%	straw, saw dust	none; removal of part of slurry; mixing; addition of water
Piglets (live weight 7.7 to 12 kg)	no data	100%	straw, saw dust	after each group of animals
Laying hens (end live weight 2 to 4 kg)	no data	0 to 100%	straw, woodchips	none, removal, drying and removal
Broilers	0.2-10 kg per year per place	100%	straw, sawdust, rice husks, wood shavings	none, drying

heap (Figure 8.3). This reduces exposure of fresh manure to air and consequently emissions of  $\text{NH}_3$  and other gases (Muck *et al.*, 1984).

Pig houses do not have automatic scrapers, because pigs are by nature curious animals that will examine the equipment and be injured when they get in the way of the moving parts. In Asia the farmyard manure is manually removed from the pig houses (Vu *et al.*, 2011).

Some pig housing systems have been developed with partially or completely solid concrete floors covered with straw or sawdust to improve the welfare of the pigs. Typically, the solid manure produced is removed either manually or with front loaders at monthly intervals. Technologies for turning the deep litter in the pig houses have been developed. The turning enhances immobilisation of the inorganic N due to aeration and the production of a more homogeneous material, which provides a better substrate for the microbes that transform the organic material. The degradation of the litter may also contribute to coupled nitrification-denitrification processes, where the inorganic N is transformed into  $\text{N}_2$ ,  $\text{N}_2\text{O}$  or  $\text{NO}_x$ . The purpose of the system is to reduce  $\text{NH}_3$  emission, keep the surface dry and largely free of pathogens, to reduce the amount of litter needed and to produce a high-quality organic material that can be used for soil amelioration and as a fertilizer.

In chicken houses the poultry excrements often have a high DM content as they dry whilst on the floor. In broiler units, chickens live on floors that have a light covering of straw. Laying hens may live in aviary housing with littered floors or in cages stacked into tiers; the cages have wire mesh floors. Conveyor belts underneath the wire mesh floors collect the droppings. The laying hens may also be housed in so-called battery cages with wire mesh floors. Usually there are several tiers and conveyor belts underneath to collect the droppings.

#### 8.4.1 Ammonia emission

Ammonia emission is related to the source strength which is affected by the amount of TAN in the manure and on pH, temperature and air flow. Dairy cattle require more feed than beef cattle and emissions from dairy cattle on deep litter are larger than from beef cattle (Table 8.4). Emissions are also related to the emitting area, which is why  $\text{NH}_3$  emissions are larger from deep

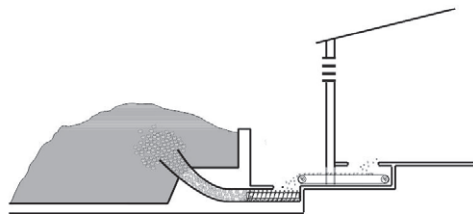

Figure 8.3. A conveyor transports the litter out of the house and a screw in the tube presses the solid manure into the bottom of a heap (courtesy of Mullerup, Skiold Mullerup, Denmark, 2011).

## 8. Eco-friendly and efficient management of solid animal manure

Table 8.4. Emission from livestock houses (Adapted from figures in Webb *et al.*, 2012).

Livestock	Housing type	NH <sub>3</sub> g NH <sub>3</sub> -N/d per animal place*	N <sub>2</sub> O g N <sub>2</sub> O-N/g/d per animal place	CH <sub>4</sub> mg C/m <sup>2</sup>
Cattle – dairy	deep litter	25	2	900
Cattle – dairy	tied stall, fym	5	0.5	175
Cattle – beef	deep litter	5	0.1	150
Pig – sows	deep litter	13		
Pig – fatteners	deep litter	9	2.7	9
Pig – piglets	deep litter	1		
Laying hens	floor, battery	0.8		
Laying hens	aviary	0.2		
Broilers	floor	0.1		

\* Animal place is the space in a house allocated to one animal.

litter systems where manure covers the entire floor than from tied stalls where manure only covers the gutter area behind the animals.

Ammonia emissions from fattening pigs on deep litter are approx. 2.3 kg NH<sub>3</sub> pig<sup>-1</sup>, or about 75% of the emissions from fattening pigs on fully slatted floors (Webb *et al.*, 2012). Emissions of NH<sub>3</sub> may be reduced by mixing the top layer once a week with a cultivator. This is because nitrification and denitrification oxidise nitrogen compounds, thus depleting TAN and in turn NH<sub>3</sub> emissions. The production of N<sub>2</sub>, NO<sub>2</sub> and N<sub>2</sub>O may account for a loss of 47% of the N excreted (Groenestein and Van Faassen, 1996). This system may be used in some housing systems and then nitrification and denitrification should be included in the calculations of the N balance.

Cattle urine will infiltrate the deep litter (sawdust or straw), reducing the surface area in contact with the air. Furthermore, deep-litter cattle houses are, in general, naturally ventilated and the transfer of NH<sub>3</sub> from the house to the free atmosphere may differ from mechanically-ventilated dairy cow housing. This will often result in a cooler environment in the naturally-ventilated house and a lower NH<sub>3</sub> emission (Webb *et al.*, 2012). Emissions may also be lower because a significant fraction of the TAN mineralized from the easily-digestible N fractions in urine and dung can be absorbed through cation exchange processes by the straw and transformed into organically-bound N by microorganisms. As a result, NH<sub>3</sub> emissions from cattle on straw-bedded systems are about two thirds of the emissions from cattle in slurry-based systems (Webb *et al.*, 2012).

Increasing the quantity of bedding material used in an animal house may result in increased immobilisation of NH<sub>4</sub><sup>+</sup> and a decrease in the airflow over the emitting surface, which is buried under the added straw. Consequently, using 33% more straw appears to reduce the NH<sub>3</sub> emission factor per pig by 20% (Gillespy *et al.*, 2009). In cattle houses this additional straw reduces emission by 50%, and using straw only in the dunging areas reduces emissions significantly in cattle

houses but not in pig houses. The type of bedding material may influence the infiltration rate, the airflow over the emitting surface and absorption of liquid effluent (influencing ammonium immobilization). Thus measured ammonia emissions from bulls on different bedding types of long straw, chopped straw and peat + chopped straw, may respectively be 58, 46 and 32 g/cow/day (Webb *et al.*, 2012). In Sweden and Finland peat is abundant and there is a tradition for spreading peat on floors. Peat has a low pH and a high cation exchange potential and can adsorb  $\text{NH}_4^+$ . It has therefore been shown to reduce  $\text{NH}_3$  emissions to about a tenth of those using straw bedding.

Poultry excrete N in the form of ureic acid that is slowly hydrolysed to urea and then to  $\text{NH}_4$ . Housing systems can greatly affect the transformation of ureic acid as the process is affected by the temperature and water content of the manure (Groot Koerkamp, 1994). At low water content the hydrolysis is hindered due to the absence of free water and at high water contents hydrolysis is reduced due to the low oxygen concentration due to reduced activity of the micro-organisms. Laying hens are often housed in battery cages. The faeces drop through the cages to a store below the cages or onto a conveyor belt which transports the manure to an external store (Groot Koerkamp, 1994). In these systems the  $\text{NH}_3$  emission is low, partly because the manure is dried on the conveyor belt and partly because the manure is continuously removed. Drying of poultry manure can lower the pH to as low as 7.3 compared to a pH of 9.6 in untreated manure (Groot Koerkamp *et al.*, 1998).

The chicken droppings may be stored dry on the floor or – after the addition of water – as a slurry in pits or channels. Poultry solid manure DM concentration may vary from 31 to 67% (Sommer and Hutchings, 2001). Kroodsma *et al.* (1988) found that in houses where manure is managed dry, water spillage from bell drinkers may double the  $\text{NH}_3$  emission due to the increased hydrolysis of ureic acid to TAN. Cabrera and Chiang (1994) saw a 50% reduction in  $\text{NH}_3$  emissions as a consequence of increasing the DM content from 30 to 80%, and Groenestein *et al.* (1993) found that the reduction in water content from drying the manure on a perforated and continuously air vented floor cut  $\text{NH}_3$  emissions to 10% of emissions from a traditional floor.

The alternative to managing the manure in a dry form is to disperse the manure in water and produce slurry. The slurry ureic acid is slowly transformed to TAN and the temperature does not increase as the transformation of organic matter is anaerobic (Groot Koerkamp, 1994). The emissions of  $\text{NH}_3$  from slurry systems are therefore low, i.e. one third of emissions from houses with manure stored in heaps on the floor.

#### **8.4.2 Greenhouse gas emission**

There are relatively few studies covering  $\text{N}_2\text{O}$  emissions from animal houses, and for pigs these are limited to a study on fatteners housed in buildings with deep litter, and the emission is in average estimated to 2.7 g  $\text{N}_2\text{O-N/d}$  per animal place (Table 8.4). The emission of  $\text{N}_2\text{O}$  from pig houses with fatteners is much higher than that from cattle houses. This is probably due to the compaction of cattle deep litter, which reduces oxygen movement to the sites of TAN and thus inhibits the nitrification process – the precursor to the formation of  $\text{N}_2\text{O}$ . From cattle houses the  $\text{N}_2\text{O}$  emission was lower from the tied than from deep litter housing system because manure is more frequently removed and probably also because FYM tends to be less porous than deep litter.

## 8. Eco-friendly and efficient management of solid animal manure

Laboratory studies have shown that in cattle deep litter more than 80% of the total transformation of carbon may take place in the aerobic 0-20 cm top layer, and much of this carbon is emitted as carbon dioxide (CO<sub>2</sub>). Below the 15-20 cm depth, about 20% of the carbon of the deep litter is transformed anaerobically to CH<sub>4</sub> and CO<sub>2</sub>. Due to CH<sub>4</sub>-oxidation during its transport from deeper layers to the surface, only between 5-15% of the total carbon (CH<sub>4</sub>+CO<sub>2</sub>) emission is in the form of CH<sub>4</sub> (Henriksen *et al.*, 2000). Nevertheless, CH<sub>4</sub> emission from solid cattle manure is still significant, and particularly so from dairy cattle on deep litter (Table 8.4).

From pig houses the mean CH<sub>4</sub> emission from the pig and litter is 6.5 g CH<sub>4</sub>-C/d per pig. The emission caused by flatus is 3.1 g/d per pig, thus the emission related to the litter is about 3.4 g CH<sub>4</sub>-C/d per pig. This is a relatively low emission rate for a system with a high CH<sub>4</sub> production potential. The low emission may be due to that the system is more aerobic, therefore, less CH<sub>4</sub> is produced in deep litter straw layers of pig deep litter than in cattle deep litter, because cattle do not aerate the bed by rooting and foraging (Szanto *et al.*, 2007). Consequently, the CH<sub>4</sub> emission per m<sup>2</sup> surface area is much lower in pig houses (Table 8.4).

### 8.5 Solid manure store

Manure needs to be stored to gain the maximum benefit of the excreta as a fertilizer for commercial crops and fish ponds. Manure is stored for the purpose of enabling a balance between manure application and crop requirements. Thus storage capacity is needed to cover the winter periods in temperate zones or for the dry periods in warmer climates with alternating wet and dry seasons. Storage may also be needed to reduce the content of pathogens and weed seeds in the manure, and as a site for quality control of the manure effluent composition, i.e. measurements of pathogens or trace metals.

In Europe, it is important that livestock farms have the capacity to store the manure when there is no crop production or no crop requirement for plant nutrients, i.e. for periods of up to nine months. If more than one crop is grown in a year or the crop growing season is long, then the manure stores may only need storage capacity of a few months. In Asia there may on some farms be no need for manure stores because the manure is continuously added to fish ponds, where the manure nourishes the plants that are eaten by herbivorous fish.

Solid manure is usually stored in uncovered heaps on concrete pads or on soil. If manure is stored on an impermeable surface, drainage is collected. In some countries solid manure is transported from the animal houses to the field, where it is stored until it is applied.

Solid manure heaps may be turned at regular intervals to enhance microbial activity. The aerobic microbial activity will increase the temperature of the heap, which can reduce pathogens and kills weed seeds (Larney and Hao, 2007). Turning also means that all the material in the heap is heated, ensuring that pathogens and seeds are reduced. Water evaporates from the manure and organic matter is transformed to the gases CH<sub>4</sub>, CO<sub>2</sub>, N<sub>2</sub>, N<sub>2</sub>O and NO<sub>x</sub> that are emitted to the atmosphere, which can collectively reduce the mass of manure by up to 50%.

An alternative to aeration may be compaction of the manure or covering it with a gas-impermeable membrane or lid. In Asia the manure may be covered with clay that prevents air from entering the heap. The objective is to stop aerobic microbial activity and thus reduce emissions of  $\text{NH}_3$  from the manure heap (Chadwick *et al.*, 2011, Webb *et al.*, 2012). Methane emissions from solid manure can be reduced by two completely different strategies aiming at either promoting or preventing anaerobic conditions. An air-tight cover may be used to cover the heap, thus preventing aerobic microbial activity and the associated increase in temperature that would otherwise stimulate  $\text{CH}_4$  emissions. Alternatively the manure may be efficiently aerated with the purpose of stimulating aerobic micro-organisms to produce  $\text{CO}_2$  and  $\text{NO}_3^-$  and thus reduce  $\text{CH}_4$  and  $\text{N}_2\text{O}$  production and emission.

Lime can be added to manure to kill pathogens, or with phosphorus to improve the fertilizer quality of the manure and also to reduce  $\text{NH}_3$  emission (Tran *et al.*, 2011).

### **8.5.1 Ammonia emission**

The loss of  $\text{NH}_3$  from stored solid manure is affected by the same chemical reactions and transport processes as for any other  $\text{NH}_3$  source. However, the origin of the emission varies considerably between different manure types and storage conditions. In solid manure with a low straw content or a high water content (>50-60%), the diffusion rate of  $\text{O}_2$  is low and composting almost non-existent and  $\text{NH}_3$  emission thus originates exclusively from the outer surface of the stack. The addition of fresh manure to the surface of the pile prevents further emissions from the previous outer surface, (which is now buried), but creates a new outer surface from which emission can occur. Each fresh addition of manure creates a new pulse of  $\text{NH}_3$  emission. If self-heating (composting) occurs, then warm air moves through the heap increasing the potential for  $\text{NH}_3$  emission. The concurrent decomposition of organic matter results in a rapid mineralisation of organic N, an increase in pH due to a reduced concentration of organic acids, which together with high temperatures will lead to high concentrations of  $\text{NH}_3(\text{g})$  and to a rapid and substantial emission. A newly created heap will be a source of  $\text{NH}_3$  for a few weeks, until the moisture content falls sufficiently to halt the process, or all the decomposable nitrogen has been emitted as  $\text{NH}_3$ , oxidized, or has converted into organic N. Losses of 25-30% of the total-N from stored pig manure and cattle deep litter have been recorded (Table 8.5 and 8.6), although losses as low as 1-10% also have been observed. These lower losses may be due to the leaching of TAN with rainwater and subsequently reduced  $\text{NH}_3$  volatilisation (Webb *et al.*, 2012).

Additions of straw will increase the C:N ratio and promote immobilisation of TAN, but large amounts of straw are required to reduce  $\text{NH}_3$  losses: in other words, a daily addition of 25 kg straw per cow would be required to reduce  $\text{NH}_3$  losses during storage by 50%. Losses can be lowered by 50-90% by decreasing the convection of air through the heap through the use of a tarpaulin cover or through litter compaction. Active composting is often a part of manure management, with the objective of reducing the mass and volume of manure to be removed and reducing the viability of weed seeds, as mentioned above, but the effect of turning of solid manure heaps has been shown to increase  $\text{NH}_3$  emissions significantly.

## 8. Eco-friendly and efficient management of solid animal manure

Table 8.5. Emissions from solid manure heaps.

Livestock	Manure category	NH <sub>3</sub>	N <sub>2</sub> O	N <sub>2</sub> O	CH <sub>4</sub>
		% of total N	g N/m <sup>2</sup> /d	N (% of total N)	% of total C
Cattle	FYM	15.1	1.3	0.9	3.5
	deep litter	7.8		0.2	0.02
	FYM tied stall	3.7		0.5	
Pig	FYM	30.8	1.9		
	deep litter	4.8		4.6	
Poultry	manure, daily removal	2.1			
	with conveyor belt litter	8.3	0.6	0.01	

Table 8.6. Ammonia emission as a percentage of total-N from stored solid manure and the DM-rich fraction from slurry separation (Hansen et al., 2008; Sommer et al., 2006).

Livestock	Manure category	NH <sub>3</sub> -N emission in pct. of total-N	
		No treatment	Compacted or covered with PVC
Pigs	solid manure	25	13
Dairy cows	solid manure	4	2
Cattle	deep litter, solid fraction from separation of slurry	8	4
Poultry	deep litter	15	7

### 8.5.2 Greenhouse gas emission

Emissions of N<sub>2</sub>O from solid manure heaps normally range from below 1% to 4% of the total-N in stored solid manure heaps (Chadwick *et al.*, 2011), but may be as large as 9.8% (Webb *et al.*, 2012). From stored chicken manure between 0.2 and 0.8% of total-N may be lost as N<sub>2</sub>O (Chadwick *et al.*, 2011).

In the initial thermophilic phase of deep litter decomposition the production of N<sub>2</sub>O is low, because the nitrification rate is low. After the thermophilic phase the N<sub>2</sub>O production increases and N<sub>2</sub>O production rates are significant during the following low-temperature period. The emissions from composting animal manure in passively aerated heaps and from turned livestock waste in windrows are between 10 and 30.0 g N/Mg. Periodic turning may ensure aerobic conditions in the whole compost pile and decrease N<sub>2</sub>O emissions (from denitrification) without any significant increase of NH<sub>3</sub> emissions as mentioned above. Still if the turning do not



efficiently aerate the solid manure then the turning of solid manure heaps can stimulate N<sub>2</sub>O emission (Chadwick *et al.*, 2011).

Addition of straw has the potential to reduce greenhouse gas emissions during solid manure storage. Large amounts have to be added – i.e. an increase of 50% (by volume) of chopped straw has been shown to reduce N<sub>2</sub>O emissions by 32% from small-scale stores of conventional cattle manure, probably due to the higher initial C:N ratio and transformation of TAN into organic N (19 compared with 14) and DM content (41% compared with 30%) of the additional straw treatment compared with the unamended manure.

An impermeable cover reduced CH<sub>4</sub> emissions from a heap of a DM-rich separated slurry fraction from 1.6 to 0.2 kg C/Mg, or from 1.3 to 0.17% of the initial C content (Hansen *et al.*, 2007). Alternatively, frequent turning can be used to reduce anaerobic zones in the heap. In one study this technique reduced CH<sub>4</sub> emissions to about 0.5% of the initial C content (Amon *et al.*, 2001). The balance between aerobic and anaerobic activity is critical. If the heap is not properly covered, or if it is compacted to a degree that air flow into the heap is very low, then the reduction in air flow into the heap may enhance emissions of CH<sub>4</sub> because reduced air flow will increase the anaerobic fraction of the manure and reduce the oxidation process but at the same time still contribute to temperature increase of the heap. This was reflected in a study by Chadwick (2005) where CH<sub>4</sub> emissions varied from 0.4 to 9.8% of the initial carbon content. The highest and lowest emissions were from manure stored in compacted and PVC-covered heaps, respectively.

## **8.6 Land application of manure**

Solid manures are spread from vehicles equipped with either an auger, slats attached to a chain, or a gate the purpose of which is to convey the solid manure onto a mechanical beater that can be mounted horizontally or vertically at the rear or at the side. The beater is a rotating device that throws the manure to the field as homogeneously as possible.

Rear-discharge machines generally apply manure more evenly than side-discharge types. Often the side-discharging machines can spread the manure across a wider band than rear-discharge machines.

### **8.6.1 Ammonia emission**

There is a dearth of studies on NH<sub>3</sub> losses from solid animal manure applied to soil compared to the vast number of studies on such emissions from applied slurry. The pattern of NH<sub>3</sub> volatilisation over time from solid manure differs from that of slurry. The initial rate of loss from solid manure is low, but volatilisation continues for a longer period, probably because the TAN from the solid manure infiltrates the soil more slowly than TAN from slurry. The few studies carried out on NH<sub>3</sub> emission from solid manure applied to soil indicate that about 50% of the loss occurs within 24 hours of application and that volatilisation may continue for about 10 days; therefore, Webb *et al.* (2012) recommend that NH<sub>3</sub> emission measurements should be continued for periods longer than 120 h.

## 8. Eco-friendly and efficient management of solid animal manure

Emissions from application of stored manure are lower than those from fresh manure, despite an increase in manure pH during storage. The cause of this is probably the reduction in the concentration of TAN (Hansen, 2004). This storage effect on the TAN concentration of the manure is not seen in all studies, but, in general, more NH<sub>3</sub> is lost when spreading manure that has been covered or compacted during storage to reduce emissions (Webb *et al.*, 2004). Turning over solid pig manure increases the immobilisation of TAN and enhances emissions during storage and consequently this treatment reduced emissions after surface spreading. Table 8.7 provides emission rates from cattle, pig and poultry manure applied in the field.

Rain will affect NH<sub>3</sub> emissions very differently depending on the amount. If rain or irrigation is above approx. 20 mm, then TAN leached from manure to the soil will reduce emissions. Rodhe *et al.* (1996) found a 30% emission reduction with 20 mm irrigation directly after spreading semi-solid manure and a smaller reduction for applied solid manure. In contrast, regular small rainfall events stop manure from drying and extend the period with emissions (Misselbrook *et al.*, 2005). For poultry manure, short rain events will increase emissions significantly, because the addition of water increases the hydrolysis of ureic acid to TAN, which can then volatilise as NH<sub>3</sub>.

Incorporation of manure into the soil reduces NH<sub>3</sub> emissions – the less efficient incorporation by disc or harrow reduces NH<sub>3</sub> emissions less than incorporation by plough. Incorporation within four hours of application reduced emissions by between 79 and 97% of TAN applied (Table 8.8). The incorporation effect is greater the more quickly it follows application. So although a plough incorporates manure much more efficiently and thus reduces NH<sub>3</sub> emissions, then, due to the slow operation of the plough the benefit may not be as large as when using a harrow that can work at almost the same speed as a manure spreader.

### 8.6.2 Greenhouse gas emission

The production and emission N<sub>2</sub>O from applied solid manure is often delayed, because microbial processes have to produce a pool of soil NO<sub>3</sub><sup>-</sup>. Emission factors (the cumulated N<sub>2</sub>O-N loss expressed as a percentage of total-N in the manure applied) can range from below 0.1 to 3% (Chadwick *et al.*, 2011). In general, N<sub>2</sub>O emission is lower from solid manure applications than from slurry application; this is due to the relatively low existing concentrations of TAN and the slow release of organic N. Nitrous oxide emissions immediately following solid manure application are generally the result of a source of NO<sub>3</sub><sup>-</sup> within the applied manure (for instance, formed

Table 8.7. Emission of ammonia, nitrous oxide and methane from solid manure applied in the field (from Webb *et al.*, 2012).

	NH <sub>3</sub> g NH <sub>3</sub> -N/g TAN	N <sub>2</sub> O g N <sub>2</sub> O-N/g TAN	CH <sub>4</sub> mg C/m <sup>2</sup>
Cattle	0.79	0.12	8
Pig	0.63	0.003	239
Poultry	0.40	0.001	3

Table 8.8. Reduction of ammonia emissions after application and incorporation of solid manure from beef cattle, fattening pigs, broilers and laying hens in percent of emissions measured without incorporation (from Webb et al., 2012).

Livestock category	Machine used for incorporation	Emission reduction % Incorporation after		
		<4h	4h	≥24h
Dairy cattle	harrow	ND	63	38
Beef cattle	harrow	ND	ND	9
Fattening pigs	plough	92	64	63
	disc	ND	61	37
Broilers	plough	ND	81	77
	disc	ND	53	24
	harrow	ND	44	ND
Laying hens	mouldboard plough	97	ND	ND
	rotary cultivator	82	ND	ND
	harrow	79	ND	ND

ND: no data

during storage or composting of the solid manure) or within the soil. The emission is generally larger from manure applied to finer soils, probably due to a slower transport of oxygen into the soil. This is also evidenced by high soil water content after rainfall triggering the production and release of N<sub>2</sub>O. Nitrous oxide emissions from applied manure decrease for livestock categories in the order cattle>pigs>poultry with statistically significant differences between them. Transport of oxygen to the manure is a most important factor. Incorporation may in some cases increase N<sub>2</sub>O production and emission because of reduced O<sub>2</sub>. In systems with a limited transport of O<sub>2</sub>, denitrification may lead to production of N<sub>2</sub> and not N<sub>2</sub>O, and thus incorporation will not enhance N<sub>2</sub>O emission (Petersen and Sommer, 2011). Thus, the emission potential will vary from year to year and also between soil types and will also be affected by application techniques.

Webb *et al.* (2012) reported an average CH<sub>4</sub> emission rate of 8 mg C/m<sup>2</sup> from cattle manure, 3 mg C/m<sup>2</sup> from chicken manure and 239 mg C/m<sup>2</sup> from pig manure. Most of the emitted CH<sub>4</sub> would probably have been in dissolution in the manure when applied to the field.

### 8.7 Modelling: methods to reduce greenhouse gas and NH<sub>3</sub> emissions by solid manure management

The following sets out an analysis of the whole manure management chain, which is a recommended procedure when assessing the effects of introducing a new technology because the treatment may increase the pollution risk down the chain of management or reduce plant uptake of minerals and nutrients. Examples of GHG and NH<sub>3</sub> emissions as affected by different

## 8. Eco-friendly and efficient management of solid animal manure

systems of managing beef cattle on deep litter are given below. Treatments either stand alone or are combinations. A standard deep litter management scheme and the following three different treatment scenarios are presented: compaction and covering the deep litter during storage (an ammonia mitigation technique), incineration after storage of deep litter, and drying and pelleting before incineration (Table 8.9).

### 8.7.1 Input to calculations

Data about amounts excreted per animal, the N, P and C content of the excreta, and the amount of straw added to the excreta are presented in Table 8.10. The amount of DM, N and C excreted and use of straw is assessed using the Danish standard production data for young cattle permanently housed (Poulsen *et al.*, 2001). It is assumed that about 40% of the VS is C and that the VS content is 80% of DM.

It is assumed that transformation of organic matter causes a C loss of about 30% from deep litter in cattle houses due to CO<sub>2</sub> and CH<sub>4</sub> (Poulsen *et al.*, 2001), and total-N loss due to NH<sub>3</sub> emissions and de-nitrification is 10%.

Table 8.9. The scenarios for deep litter management from calf houses with a bedding material of wheat straw. The manure is removed from the animal house at 3 to 4-month intervals.

Scenario	Storage conditions & treatments	Application
1. Baseline	No additional treatment, stored more than 90 days	Manure applied before crop growing season
2. Compaction and covering	Manure is compacted or covered by PVC, stored more than 90 days	Manure applied before plant growing season
3. Incineration	Stored more than 90 days. Incinerated	Ash residue applied before plant growing season
4. Drying, pelleting and incineration	Deep litter not stored. Dried and pelleted and incinerated later	Ash applied to fields before plant growing season

Table 8.10. Manure and nutrient excretion by beef cattle permanently housed. Excretion is per animal per year.

	Manure (Mg)	DM (%)	DM (kg)	N (kg)	C (kg)	P (kg)
Faeces	3.0	19.7	600	13.3	180	4.8
Urine	1.6	4.9	80	23.3	24	0.1
Straw	1.3	85	1105	4.2	331	1

## S.G. Sommer

Ammonia and N<sub>2</sub>O emissions from deep litter are given in Table 8.11; the emission data given above have to be recalculated to give figures relative to N and C in the manure.

In addition to the emissions of GHG and NH<sub>3</sub> also CO<sub>2</sub> and N<sub>2</sub> is emitted. Deep litter stored outdoors can lose about 40% of its C content due to CH<sub>4</sub> and CO<sub>2</sub> production and emission (Sommer, 2001), and total N loss due to denitrification, NH<sub>3</sub> loss and leaching can be set to 20% (min 12% and max 28%; Sommer, 2001). Further, about 30% of organic N may be transformed to TAN during storage in heaps (Hansen *et al.*, 2008). With these factors and the emission factors given in Table 8.11, the he CH<sub>4</sub>, N<sub>2</sub>O and NH<sub>3</sub> emissions from the management chain of deep litter from beef cattle are calculated.

In scenario 3 incineration of stored manure contributes to energy production, but there will also be some energy expenditure from evaporation of water in the manure. There is an energy gain of 17.2 MJ/kg VS incinerated, and an energy use of 2.6 MJ/kg water evaporated. The CO<sub>2</sub> reduction by substituting power and heat produced on coal fired power plants is taken to be 0.102 kg CO<sub>2</sub>/MJ.

In scenario 4 the deep litter from the animal house is dried and pelleted. The energy cost of drying is given the same value as evaporating the water, to which is then added 20% in energy demand for pelleting and running the equipment. It is assumed that NH<sub>3</sub> is retained in an acid scrubber.

The effects of deep litter/ash application on soil organic carbon (SOC) is calculated using the model of Sommer *et al.* (2009), which means that for a Danish manure management system the CO<sub>2</sub> sequestration is 41% W/W) of VS. If the climate is warmer, the sequestration rates will be lower, for example for Italy the rate is 33%.

Table 8.11. Factors for assessing gas emission from deep litter in beef cattle houses.

	N <sub>2</sub> O	CH <sub>4</sub>	NH <sub>3</sub>
Housing	0.7% of N excreted	2g C/d/animal <sup>2</sup> or 0.14% of total-C	25 g N/d/animal <sup>1</sup> i.e. 4.5% of total-N
Storage	0.2% of total-N	0.02% of total-C <sup>1</sup> Separated manure 1.4% of total-C	8% N of total-N <sup>1</sup>
Storage compacted	0.002% of total-N	0.002	4% of total-N <sup>3,4</sup>
Applied to soil surface	12% of TAN	0	100% of TAN <sup>1</sup>

<sup>1</sup> Web *et al.*, 2011.

<sup>2</sup> Assessed by S.G. Sommer. Total 900 g C/d/ animal (animal and deep litter) is mentioned in Web *et al.* (2011).

<sup>3</sup> Chadwick *et al.*, 2011.

<sup>4</sup> Hansen *et al.*, 2006, 2008.

### 8.8 Discussion

Covering and compacting cattle deep litter heaps will markedly reduce N<sub>2</sub>O, NH<sub>3</sub> and CH<sub>4</sub> emissions from the stored deep litter (Scenario 2, Tables 8.12 and 8.13). The deep litter applied in the field are not incorporated, therefore, emission of NH<sub>3</sub> from the field applied deep litter is high, and in total more NH<sub>3</sub> is volatilised from this system than from the system where the heaps are not covered or compacted (i.e. Scenario 1). NH<sub>3</sub> emission is higher from the scenario with compacted deep litter, because denitrification losses have been reduced by compaction, therefore, the deep litter from compacted and covered heaps contain more TAN which can volatilize after application in the field than deep litter from heaps in the baseline scenario (Scenario 1). Due to the high TAN amount in field applied deep litter the N<sub>2</sub>O emission is high and in total the N<sub>2</sub>O emission is higher from the system with compaction of the deep litter heap than from the baseline system. Thus, the deep litter has to be incorporated into the soil to reduce NH<sub>3</sub> emission if compaction of stored deep litter is to be an improvement.

Table 8.12. Ammonia emission (in kg N) from deep litter produced during one year by beef cattle (Table 8.10) for the four different treatment scenarios (see Table 8.9).

	Houses	Stores	Field	Total
1. Baseline	1.8	2.9	14.1	18.9
2. Compact storage	1.8	1.5	17.8	19.3
3. Incineration	1.8	2.9	0.0	4.8
4. Drying, pelleting and incineration	1.8	0.0	0.0	1.8

Table 8.13. Greenhouse gas emissions (in kg CO<sub>2</sub> eqv) from deep litter treated as presented in Table 8.1. A negative emission means that the treatment reduces CO<sub>2</sub> emission to the atmosphere.

Scenario	Houses		Stores		Field		Carbon sequestration	Energy consumption	Energy production	Total GHG balance, CO <sub>2</sub> eqv
	CH <sub>4</sub>	N <sub>2</sub> O	CH <sub>4</sub>	N <sub>2</sub> O	CH <sub>4</sub>	N <sub>2</sub> O				
1. Baseline	137.8	265.7	13.8	68.3	0.0	1,576.3	-337.8	0.0	0.0	1,724.1
2. Compaction	137.8	265.7	1.4	0.7	0.0	1,986.2	-450.4	0.0	0.0	1,941.4
3. Incineration	137.8	265.7	13.8	68.3	0.0	0.0	0.0	0.0	-339.2	146.4
4. Drying, pelleting and incineration	137.8	265.7	0.0	0.0	0.0	0.0	0.0	1,123.4	-1,674.9	-148.0

Methane emission is higher from the baseline system than from the system with compacted deep litter heap. Nitrous oxide have a climate warming effect about 10 time higher than that of CH<sub>4</sub>, therefore, GHG emission from the system with compacted deep litter is higher than from the baseline system (Table 8.13).

Incineration and drying, pelleting and incineration (Scenarios 3 and 4) reduce GHG and NH<sub>3</sub> emission. C is transformed to climate warming neutral CO<sub>2</sub> in the incineration process because the feed is a recyclable biomass. TAN is transformed to N<sub>2</sub> due to incineration and NO<sub>x</sub> filtering and the ammonia volatilised during drying and pelleting is retained in an acid scrubber.

## **8.9 Conclusions**

The same pattern of GHG emissions is seen as for the NH<sub>3</sub> emission (Table 8.13). Emission of N<sub>2</sub>O from the deep litter applied in the field causes overall GHG emissions to be larger from compacted deep litter (Scenario 2) than from the baseline (Scenario 1). The DM concentration of the deep litter removed from the animal house is 30% and for the solid manure after storage, the figure is similar, because both DM and water is lost due to composting during storage outside. Consequently, the energy surplus when incinerating manure from beef cattle is significantly reduced if the untreated deep litter have been stored prior to incineration (Scenario 3), and is low compared to drying the deep litter and then burning the dried and pelleted deep litter (Scenario 4). There is no N<sub>2</sub>O emission from field manure in Scenarios 3 and 4 where the biomass has been incinerated. Further, there is no GHG emission from the very dry deep litter pellets during storage. From incinerated deep litter (Scenarios 3 and 4) the GHG emission is therefore much lower than from the baseline Scenario 1.

The energy produced in the two incineration Scenarios (3 and 4) will substitute energy from coal firing and consequently reduce the overall carbon footprint of the manure handling operation.

## **References**

- Amon, B., Amon, T., Boxberger, J. and Alt, C., 2001. Emissions of NH<sub>3</sub>, N<sub>2</sub>O and CH<sub>4</sub> from dairy cows housed in a farmyard manure tying stall (housing, manure storage, manure spreading). *Nutrient Cycling in Agroecosystems* 60: 103-113.
- Burton, C.H. and Turner, C., 2003. *Manure management: treatment strategies for sustainable agriculture*, 2<sup>nd</sup> Edition, Silsoe Research Institute, Silsoe, UK.
- Cabrera, M.L. and Chiang, S.C., 1994. Water content effect on denitrification and ammonia volatilization in poultry litter. *Soil Science Society America Journal* 58: 811-816.
- Chadwick, D.R., 2005. Emissions of ammonia, nitrous oxide and methane from cattle manure heaps: effect of compaction and covering. *Atmospheric Environment* 39: 787-799.
- Chadwick, D., Sommer, S.G., Thorman, R., Fanguero, D., Cardenas, L., Amon, B. and Misselbrook, T., 2011. Manure management: implications for greenhouse gas emissions. *Animal Feed Science and Technology* 166: 514-531.
- Gilhespy, S.L., Webb, J., Chadwick, D.R., Misselbrook, T.H., Kay, R., Camp, V., Retter, A.L. and Bason, A., 2009. Will additional straw bedding in buildings housing cattle and pigs reduce ammonia emissions? *Biosys Engineering* 102: 180-189.

## 8. Eco-friendly and efficient management of solid animal manure

- Groenestein, C.M., Oosthoek, J. and Van Faassen, H.G., 1993. Microbial processes in deep-litter systems for fattening pigs and emission of ammonia, nitrous oxide and nitric oxide. In: Verstegen, M.W.A., Den Hartog, L.A., Van Kempen, G.J.M. and Metz, J.H.M. (eds.) Nitrogen flow in pig production and environmental consequences. Proceedings of the First International Symposium. Pudoc Scientific Publishers, Wageningen, the Netherlands, pp. 307-312.
- Groenestein, C.M. and Van Faassen, H.G., 1996. Volatilization of ammonia, nitrous oxide and nitric oxide in deep litter systems for fattening pigs. *Journal of Agricultural Engineering Research* 65: 269-274.
- Groot Koerkamp, P.W.G., 1994. Review on emissions of ammonia from housing systems for laying hens in relation to sources, processes, building design and manure handling. *Journal of Agricultural Engineering Research* 59: 73-87.
- Groot Koerkamp, P.W.G., Speelman, L. and Metz, J.H.M., 1998. Litter composition and ammonia emission in aviary houses for laying hens. Part I. Performance of a litter drying system. *Journal of Agricultural Engineering Research* 70: 375-382.
- Hansen, M.N., 2004. Influence of storage of deep litter manure on ammonia loss and uniformity of mass and nutrient distribution following land spreading. *Biosys Engineering* 87: 99-107.
- Hansen, M.N., Henriksen, K. and Sommer, S.G., 2006. Observations of production and emission of greenhouse gases and ammonia during storage of solids separated from pig slurry: effects of covering. *Atmospheric Environment* 40: 4172-4181.
- Hansen, M.N., Henriksen, K. and Sommer, S.G., 2007. Observations of production and emission of greenhouse gases and ammonia during storage of solids separated from pig slurry: effects of covering. *Atmospheric Environment* 40: 4172-4181.
- Hansen, M.N., Sommer, S.G., Hutchings, N.J. and Sørensen, P., 2008. Emissionsfaktorer til beregning af ammoniakfordampning ved lagring og udbringning af husdyrgødning (Emission factors for calculation of ammonia volatilization by storage and application of animal manure) DJ F husdyrbrug nr. 84, Tjele, Denmark.
- Henriksen, K., Olesen, T. and Rom, H.B., 2000. Kulstof og kvælstof – omsætningsprocesser i kvægdymbstrøelse (Carbon and nitrogen – transformation in deep litter in cattle housing). In: Sommer, S.G. and Eriksen, J. (eds.) Husdyrgødning og kompost. Forskningscenter for Økologisk Jordbrug, Tjele, Denmark.
- Hjorth, M., Christensen, K.V., Christensen, M.L. and Sommer, S.G., 2010. Solid-liquid separation of animal slurry in theory and practice: a review. *Agronomy for Sustainable Environment* 30(1): 153-180.
- Kroodsma, W., Scholtens, R. and Huis, J., 1988. Ammonia emission from poultry housing systems. In: Nielsen, V.C., Voorburg, J.H. and L'Hermite, P. (eds.) Volatile emissions from livestock farming and sewage operations. Elsevier Applied Science, London, UK, pp. 152-161.
- Larney, F.J. and Hao, X., 2007. A review of composting as a management alternative for beef cattle feedlot manure in southern Alberta, Canada. *Bioresource Technology* 98: 3221-3227.
- McCarthy, G., Lawlor, P.G., Coffey, L., Nolan, T., Gutierrez, M. and Gardiner, G.E., 2011. An assessment of pathogen removal during composting of the separated solid fraction of pig manure. *Bioresource Technology* 102: 9059-9067.
- Misselbrook, T.H., Nicholson, F.A. and Chambers, B.J., 2005. Predicting ammonia losses following the application of livestock manure to land. *Bioresource Technology* 96: 159-168.
- Muck, R.E., Guests, R.W. and Richards, B.K., 1984. Effect of manure storage design on nitrogen conservation. *Agricultural Wastes* 10: 205-220.
- Petersen, S.O. and Sommer, S.G., 2011. Ammonia and nitrous oxide interactions – the role of manure organic matter management. *Animal Feed Science and Technology* 166-167: 503-513.



- Poulsen, T.G. and Moldrup, P., 2007. Air permeability of compost as related to bulk density and volumetric air content. *Waste Management Research* 25: 343-351.
- Poulsen, H.D., Børsting, C.F., Rom, H.B. and Sommer, S.G., 2001. Kvælstof, fosfor og kalium i husdyrgødning – normtal 2000 (Standard values of nitrogen, phosphorous and potassium in animal manure). DJF-Report – Husdyrgødning nr. 36. Miljøministeriet for fødevarer, landbrug og fiskeri. Danmarks Jordbrugsforskning, Tjele, Denmark, 152pp.
- Rodhe, L., Salomon, E. and Rammer, C., 1996. Spreading of farmyard manure to ley with different methods. Yield and silage quality. *Swedish Journal of Agricultural Research* 26: 43-51.
- Szanto, G.L., Hamelers, H.V.M., Rulkens, W.H. and Veeken, A.H.M., 2007. NH<sub>3</sub>, N<sub>2</sub>O and CH<sub>4</sub> missions during passively aerated composting of straw-rich pig manure. *Bioresource Technology*: 2659-2670.
- Sommer, S.G., 2001. Effect of composting on nutrient loss and nitrogen availability of cattle deep litter. *European Journal of Agronomy* 14: 123-133.
- Sommer, S.G., Olesen, J.E., Petersen, S.O., Weisbjerg, M.R., Valli, L., Rohde, L. and Béline, F., 2009. Region-specific assessment of greenhouse gas mitigation with different manure management strategies in four agroecological zones. *Global Change Biology* 15: 2825-2837.
- Sommer, S.G. and Hutchings, N.J., 2001. Ammonia emission from field-applied manure and its reduction. *European Journal of Agronomy* 15: 1-15.
- Sommer, S.G., McGinn, S.M., Hao, X. and Larney, F.J., 2004. Techniques for measuring gas emissions from stockpiled cattle manure. *Atmospheric Environment* 38: 4643-4652.
- Sommer, S.G., Zhang, G.Q., Bannink, A., Chadwick, D., Hutchings, N.J., Misselbrook, T., Menzi, H., Ni, J.-Q., Oenema, O., Webb, J. and Monteny, G.-J., 2006. Algorithms determining ammonia emission from livestock houses and manure stores. *Advances in Agronomy* 89(6): 261-335.
- Steinfeld, H., Gerber, P., Wassenaar, T., Castel, V., Rosales, M. and De Haan, C., 2006. *Livestock long shadow – Environmental issues and options*. FAO, Rome, Italy.
- Sutton, M.A., Oenema, O., Erisman, J.W., Leip, A., Van Grinsven, H. and Winiwarer, W., 2011. Too much of a good thing. *Nature* 472: 159-161.
- Tran, M.T., Vu, T.K.V., Sommer, S.G. and Jensen, L.S., 2011. Gaseous loss of nitrogen from pig manure during slurry storage and composting under typical Vietnamese farming conditions. *Journal of Agricultural Science* 149: 285-296.
- Vu, T.K.V., Vu, C.C., Médoc, J.M., Flindt, M.R. and Sommer, S.G., 2011. Management model for assessment of nitrogen flow from feed to pig manure after storage in Vietnam. *Environmental Technology* 33: 725-731.
- Webb, J., Chadwick, D. and Ellis, S., 2004. Emissions of ammonia and nitrous oxide following incorporation into the soil of farmyard manures stored at different densities. *Nutrient Cycling in Agroecosystems* 70: 67-76.
- Webb, J., Sommer, S.G., Kuppert, T., Groenestein, K., Hutchings, N.J., Eurich-Menden, B., Rodhe, L., Misselbrook, T.H. and Amon, B. 2012. Emissions of Ammonia, Nitrous Oxide and Methane during the Management of Solid Manures. *Sustainable Agriculture Reviews* 8: 67-107.

## **Part 4**

# **Ventilation and thermal environment**



## 9. Housing designs that optimize an animal's thermal environment

*L.D. Jacobson*

*Department of Bioproducts and Biosystems, University of Minnesota, St. Paul, MN 55108, USA;  
jacob007@umn.edu*

Modern animal housing systems need to provide optimum thermal conditions to maximize the animal's genetic growth potential and performance as well as meeting an essential component of an animal welfare/well-being program. The environmental conditions include parameters such as room temperature and humidity, air speed across the animal, the indoor air quality for confinement facilities, respiration rates for animal in outside lots, plus others features like light and noise levels conducive to the animal's comfort and well-being.

Environmental control systems in animal production units also need to be integrated into the overall housing system design rather than added on at the end of the design and/or construction process. Effective management and operation of these environmental control systems is as important as the design and selection of components. Latest technologies such as solid state electronic controllers need to be used to provide more precision and reliability in the operation and control of such critical criteria as exhaust fans operation or sprinklers in an outside feed yard. However, it is still very important that the person(s) managing the control instruments and devices in the field, understand how the environmental control system works and how it can be adjusted to maximize the system's effectiveness.

The thermal requirements for various species of livestock and poultry are well documented. Mammals and birds are homeotherms, since they are able to keep a relative constant core body temperature (39 °C for food mammals and 41 °C for domestic birds, Curtis, 1983) over a wide range of environmental temperatures. Even though pigs, cattle, and chickens can survive over a wide range of environmental temperatures, we are most interested in what is commonly called the thermoneutral zone. Figure 9.1 shows the relative response of key production parameters, such as feed intake, growth rate and feed efficiency, for grow-finishing pigs (average weight of 70 kg) over a normal range of environmental temperatures (5 to 33 °C) that might be experienced. The thermoneutral (sometimes called thermal-comfort) zone is highlighted by the vertical bars on the figure and can be defined as the condition where the animal is neither cold nor heat stressed. More importantly for our discussion, this range of environmental temperatures is where the critical production parameters of growth (average daily gain, ADG) and feed efficiency (FE) are optimum. Thus, this is the target or 'sweet spot' temperatures for any environmental control system in a livestock building.

The environmental temperature range for the thermoneutral zone will vary by animal species with a relatively narrow range (2 or 3 °C) for small animals (birds) and a much wider range (from 5 to 10 °C) for larger animals such as finishing pigs or cattle. The low and high end of this range is called the lower (LCT) and upper critical temperatures (UCT) respectively. Depending on the season and where the housing system is located in the world, the target temperature or goal of

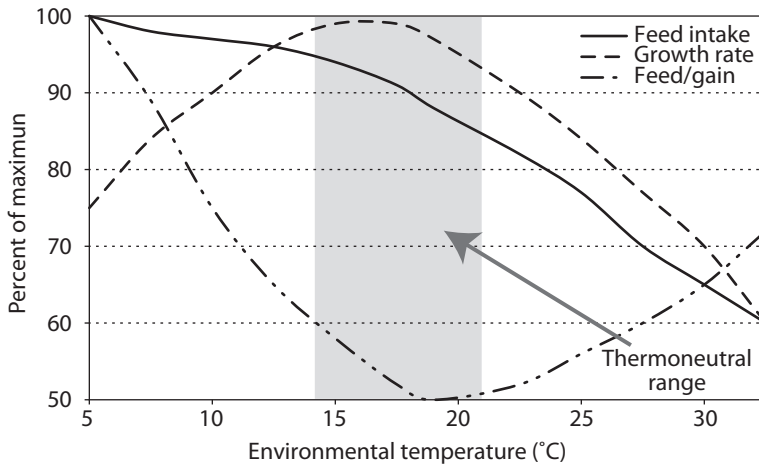

Figure 9.1. Effect of environmental temperature on growing-finishing pig performance (Coffey et al., 1995).

the environmental control system may be one of these temperatures. For instance, in a temperate region of the world that experiences cool and/or cold climates for several months of the year, the target would be the LCT during the cold months, since a limited amount of supplement heat (generally provided by fossil fuel) would be required to maintain this temperature if insufficient animal heat is available. In contrast, in warm or hot climate locations, the target would be the UCT, which still can be quite low especially for large animals. Most animal housing systems, even those in temperate parts of the world, have a much greater difficulty trying to meet the UCT requirements with their environmental control system. Simply said, most animals raised in confinement operations (both inside and outside) are heat stressed to some degree since they produced large quantities of heat and whenever the ambient temperature is above the UCT some type of cooling systems should be deployed to either meet the UCT or limit the rise about this threshold for the particular animal.

Thus a majority of the time, even in temperate climates, the environmental control system is removing heat produced by the animals and thus regulating the barn’s temperature or animal comfort level during warm or hot times of the year and often limiting the rise in the barn’s temperatures above the UCT. The environmental control system accomplishes this heat removal through one of the indicate heat transfer pathways shown in Figure 9.2. Most people only think that the removal of heat (cooling) from an animal is done by moving air (forced convection) over the animal. As Figure 9.2 shows, there are other pathways that are available and depending on the animal they can be more efficient and effective in cooling the animal than the forced convection route. For instance, the evaporation (periodic wetting and drying of an animal’s skin by water sprinkling) is a very effective and efficient way to remove heat from an animal and the building it is housed in. This is eloquently detailed in a paper in this book by Hoff (2012). Also in this book, Brown-Brandl (2012), describes how to manage thermal stress in feedlot cattle, from providing insulated surfaces in buildings or shades that reduce radiate heating to details on

## 9. Housing designs that optimize an animal's thermal environment

specific individual animals in a building or feedyards that may be more susceptible because of skin coloration or health condition. Finally, Banhazi and Rutley (2012), identify in their chapter some key building features that affect the thermal control in pig building from a large sampling of temperature data in commercial facilities. All of these papers discuss and explore the basic heat loss/gain pathways outlined in Figure 9.2.

Optimizing an animal's thermal environment is even further complicated by the new development in animal genetics. With today's faster growing and leaner animals they typically produce significantly more (as much as 20% more) heat than animals from 20 or even 10 years ago. Thus designers of animal housing and environmental control systems need to be sure that the most recent heat and moisture production data is used, since it can easily shift the thermoneutral zones for animals 2 or 3 °C and result in more frequent heat stress conditions and thus the greater need for effective environmental control systems and management strategies to optimize performance and provide the necessary animal comfort and well-being.

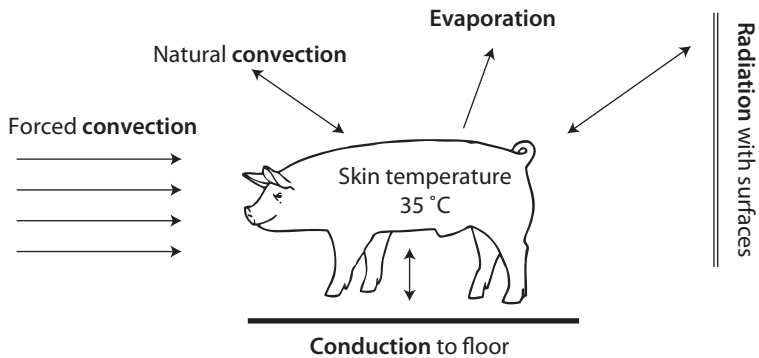

Figure 9.2. How heat is transferred from the pig to its surroundings.

## References

- Banhazi, T. and Rutley, D., 2012. Constructing better piggery buildings by identifying factors contributing to improved thermal control under hot climatic conditions. In: Aland, A. and Banhazi, T. (eds.) *Livestock housing: modern management to ensure optimal health and welfare of farm animals*. Wageningen Academic Publishers, Wageningen, the Netherlands, pp. 237-257.
- Brown-Brandl, T.M., 2012. Managing thermal stress in feedlot cattle: environment, animal susceptibility, and management options from a US perspective. In: Aland, A. and Banhazi, T. (eds.) *Livestock housing: modern management to ensure optimal health and welfare of farm animals*. Wageningen Academic Publishers, Wageningen, the Netherlands, pp. 189-208.
- Coffey, R.D., Parker, G.R. and Laurent, K.M., 1995. Feeding growing-finishing pigs to maximize lean growth rate. University of Kentucky Cooperative Extension Service, ASC-147.
- Curtis, S.E., 1983. *Environmental Management in Animal Agriculture*. Iowa State University Press, Ames, Iowa, USA.

Hoff, S.J., 2012. The impact of ventilation and thermal environment on animal health, welfare and performance. In: Aland, A. and Banhazi, T. (eds.) *Livestock housing: modern management to ensure optimal health and welfare of farm animals*. Wageningen Academic Publishers, Wageningen, the Netherlands, pp. 209-235.

# 10. Managing thermal stress in feedlot cattle: environment, animal susceptibility and management options from a US perspective

*T.M. Brown-Brandl*

*U.S. Meat Animal Research Center, P.O. Box 166, Clay Center, Nebraska 68933, USA;*

*tami.brownbrandl@ars.usda.gov*

## Abstract

Extreme summer time conditions can have a devastating impact on livestock, especially those animals who are typically housed outdoors without shelter, such as feedlot cattle. The effect of heat stress on feedlot cattle can vary from little to no effect in a brief exposure, to causing reductions in feed intake, growth and feed efficiency in a moderate event, to death of vulnerable animals during an extreme event. Heat stress can be broken down into three sub-components: environmental conditions, susceptibility of the individual animal and the management options employed. This chapter describes the economic impact of heat stress, factors affecting an individual animal's susceptibility to heat stress and the management options that can be used to decrease the impact. In addition, the chapter will start to layout the means to combine these three factors into a management strategy.

**Keywords:** heat stress, cattle, economic losses, thermal environment, precision animal management

## 10.1 Introduction

This chapter's aim is to provide an in depth look at thermal stress in cattle. The first aspect to be discussed is why thermal stress is important and the economic impacts of heat stress. Then heat stress is broken down into three independent components: environmental conditions, animal susceptibility and management strategies. Finally, a new management strategy is discussed, the application of precision animal management. By combining of the three different components (environmental conditions, animal susceptibility and management strategies) into a single management strategy; an appropriate level of care for each animal to maximize the cost to benefit ratio of each management strategy can be provided.

## 10.2 Economic impact of heat stress in feedlot cattle

The economic losses associated with heat stress originate from three primary factors including decreased performance, increased mortality and decreased reproduction (St-Pierre *et al.*, 2003). When losses are summarized for the United States over an entire summer season, the average estimated losses over all livestock species are US\$ 2.4 billion and US\$ 369 million is associated with feedlot cattle. To put this in perspective, the total US livestock receipts in 2010 were US\$ 70.5 billion, of which US\$ 51.5 billion were for the cattle. Thus, the estimated heat stress losses



estimated by St. Pierre *et al.* (2003) are about 3.4% for all livestock species and a little less than 1% for cattle. While the overall percentages may seem insignificant, deaths during a single localized event can be economically overwhelming to individual producers in affected regions during these summertime events.

Periods of extreme heat are generally referred to as a heat wave. A heat wave has been defined as 'a period of abnormally hot and unusual humid weather of at least one day in duration, but conventionally lasting several days to several weeks' (AMS, 1989). Hahn and Mader (1997) reported an operational definition of heat waves as '3-5 successive days with maximum temperatures above a threshold, such as 32 °C.' During a heat wave, the environmental conditions have negative impacts on the animal's growth, performance and can result in death in extreme cases.

Heat waves are a reoccurring phenomenon over the cattle producing regions of the United States. Several severe heat waves have occurred in the Midwestern US in the last 10 years that have resulted in substantial losses for the feedlot industry. In July 1995, nearly 4,000 head of feedlot cattle were lost in southwestern Iowa with total losses approaching US\$ 28 million. More than 5,000 head of feedlot cattle were lost in July 1999 in northeast Nebraska; monetary losses were reported between US\$ 21.5 and US\$ 35 million. Other severe heat related cattle losses occurred in northeast Nebraska (July 2005), in north central South Dakota (July 2007), in central Nebraska (June 2009) and in central Kansas (July 2010) and across the upper Midwest (July-Aug 2011). Each of these events has resulted in the death of thousands of feedlot cattle and the loss of millions of dollars in revenue to the cattle industry, both in direct animal losses and indirect performance losses (Busby and Loy, 1996; Hahn, 1999; Hubbard *et al.*, 1999b) to a localized area impacting a relatively small number of producers.

The total impact of the heat wave is dependent on the interaction of several factors including: (1) environmental conditions; (2) animal susceptibility; and (3) animal management strategies. These factors are interactive and each of them needs to be considered when making management decisions.

### **10.3 Environmental conditions**

While temperature is the primary parameter used to describe the weather, other parameters have been shown to impact the total heat load. Solar radiation, humidity and wind speed are three additional parameters that are considered important to animal stress (MLA, 2006b). Several mathematical models have been developed to help summarize these components into a single usable number (Eigenberg *et al.*, 2005; Gaughan *et al.*, 2008; Mader *et al.*, 2006; Thom, 1959).

The temperature-humidity index (THI) has been used for many years and combines the effects of temperature and humidity (Thom, 1959). THI was subsequently used by the transportation industry to provide livestock shipping guidelines during heat stress conditions (LCI, 1970). As a component of the guidelines, Livestock Conservation, Inc. developed the Livestock Weather Safety Index based on the following four THI categories: Normal,  $THI < 74$ ; Alert,  $74 < THI < 79$ ; Danger,  $79 < THI < 84$ ; and Emergency,  $THI > 84$ . The THI equation is shown in Equation 10.1:

$$\text{THI} = 0.8t_{\text{db}} + \text{RH} (t_{\text{db}} - 14.4) + 46.4 \quad (10.1)$$

where  $t_{\text{db}}$  is dry-bulb temperature in °C and RH is relative humidity in decimal form.

While THI accounts for the effects of temperature and humidity, the effects of wind speed and solar radiation are not considered. In the case of housed animals exposed to low air velocity and little or no solar radiation, THI does a reasonable approximation of summarizing the environment. However, in the case of beef cattle and other animals typically held in open-air pens, the wind speed and solar radiation are significant contributors to the total heat load.

Several researchers have worked towards an index that accounts for all of these factors. The more recently developed equations combine temperature, humidity, wind speed and solar radiation (Eigenberg *et al.*, 2005; Gaughan *et al.*, 2008; Mader *et al.*, 2006; Thom, 1959). Respiration rate has been shown to be a good indicator of heat stress (Brown-Brandl *et al.*, 2005b; Gaughan *et al.*, 2000). Therefore, an equation was developed by Eigenberg *et al.* (2005) to predict respiration rate ( $\text{RR}_{\text{est}}$ ) as shown in Equation 10.2:

$$\text{RR}_{\text{est}} = 5.1t_{\text{db}} + 0.58\text{RH} - 1.7v_w + 0.039r_s - 52.8 \quad (10.2)$$

where  $t_{\text{db}}$  is dry-bulb temperature, RH is relative humidity in percentage,  $v_w$  is wind speed in m/s and  $r_s$  is solar radiation in  $\text{W}/\text{m}^2$ .

Mader *et al.* (2006) developed an adjustment to THI by including two additional factors, wind speed and solar radiation (Equation 10.3):

$$\text{THI}_{\text{adj}} = 4.51 + \text{THI} - 1.992v_w + 0.0086r_s \quad (10.3)$$

where THI is temperature humidity index (as calculated above),  $v_w$  is wind speed in m/s and  $r_s$  is solar radiation in  $\text{W}/\text{m}^2$ .

Equations 10.1-10.3 estimate heat stress based on only the current conditions. However, the heat load can be accumulated over a period of time. An hour of extreme temperature will not have the same impact as three extreme days with little or no night-time cooling. To address this effect, THI hours (Hahn *et al.*, 1999; Hubbard *et al.*, 1999a) can be calculated above an emergency threshold (i.e.  $\text{THI}=84$ ). Equation 10.4 describes the environment by summing the hours (h) and the degrees above a threshold such as 84. Similar THI hours calculations have been performed with THI hours above 79 (Nienaber *et al.*, 2007).

$$\text{THI hours} = \sum_{h=1}^{24} (\text{THI} - 84) \quad (10.4)$$

The other important factor in evaluating the intensity of heat is the night-time recovery. The recovery hours at night allow the animals to dissipate excess heat and return their body temperature to normal levels. Various recovery levels have been reported and used including THIs below 74 (Hubbard *et al.*, 1999a), below 72 (Hahn, 1999) and below 70 (Nienaber *et al.*, 2007).

Gaughan *et al.* (2008) developed the heat load index which includes all the weather parameters (temperature, humidity, wind speed and solar radiation) and also factors for accumulation and recovery. The initial calculation of the index requires several equations. First, black globe temperature ( $t_{bg}$ ) is used instead of ambient temperature, as this summarizes temperature and solar radiation (Turco *et al.*, 2008). The heat load index (HLI) is calculated by using Equations 10.5 or 10.6. Equation 10.5 is used when  $t_{bg} < 25$  °C and Equation 10.6 is used when  $t_{bg} \geq 25$  °C:

$$HLI = 10.66 + 0.28 \times RH + 1.3 \times t_{bg} - v_w \quad (10.5)$$

$$HLI = 8.62 + 0.38 \times RH + 1.55 \times t_{bg} - 0.5 \times v_w + e^{(-v_w + 2.4)} \quad (10.6)$$

where RH is relative humidity in percentage,  $t_{bg}$  is black globe temperature in °C and  $v_w$  is wind speed (m/s).

The HLI can be accumulated and dissipated depending on selected threshold values. The upper threshold for the accumulated heat load units (AHLU) is determined by a combination of animal and management factors. The base upper threshold is 86. Units are accumulated by summarizing hourly differences between average HLI and the upper threshold. The AHLU is dissipated when the HLI value falls below 77 and the accumulated values are summarized hourly (Gaughan *et al.*, 2008).

Nienaber *et al.*, (2007) compared three different indices ( $RR_{est}$ ,  $THI_{adj}$  and AHLU) with  $THI_{hours}$ . Each of the models correctly identified the events described by the criteria outline in Hahn *et al.* (1999). However, the  $THI_{adj}$  tended to be more conservative and had higher scores. AHLU, was designed for accumulative values was accurate unless extreme events occurred. The  $RR_{est}$  model was less sensitive and indicated more recovery opportunity than all other indices. It was concluded that the application of any of these models could provide valuable information on the predicting of heat waves.

## 10.4 Animal susceptibility

The overall impact of extreme heat stress on feedlot cattle is quite varied (Hahn *et al.*, 1999), from little stress to death. Even within the same feedlot, the impact between individual animals varies immensely. During an extreme event, mortality in a single pen can exceed 25% of the animals (Hungerford *et al.*, 2000). When animal heat stress data (e.g. respiration rate in breaths per minute) are viewed in relation to environmental parameters (dry-bulb temperature, °C), the variation in responses is evident (Figure 10.1). For example, at an ambient temperature of 32.9 °C, the response in respiration rate for an entire collection of feedlot cattle varies between 78 and 167 breaths per minute (bpm). The question arises: what causes these variations in response?

The two extremes in respiration rates (78 and 167 bpm) were recorded on the same day for two different heifers in the same feedlot. To determine if these differences were only random or if the animals truly responded differently, all of the observations for these two individual heifers collected throughout the summer were extracted and plotted on a separate graph (Figure 10.2). Upon closer inspection, it is apparent that while there are fluctuations in the respiration rate, there

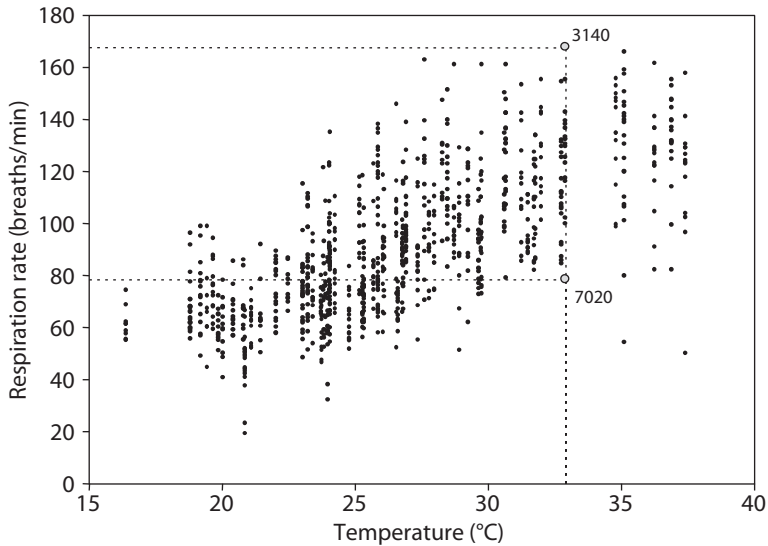

Figure 10.1. Response in respiration rate of multiple feedlot heifers over a 3-month summer period exposed to a variety of different environmental conditions. The two gray points, labeled 3,140 and 7,020, represent the varied responses of two individual heifers exposed to the same environmental conditions on the same day (from Brown-Brandl and Jones, 2011).

are distinct differences in the responses of these individual animals to the same environmental conditions and management practices (Figure 10.2).

Several authors have noted different factors which can increase animal susceptibility to heat stress. Brown-Brandl and Jones (2011) developed a susceptibility model to summarize the many factors which increase an animal's susceptibility to heat stress (Figure 10.3). The knowledge used to develop the model was based upon published data. The susceptibility factors include species of cattle, as *Bos taurus* cattle are more vulnerable to heat stress than either *Bos indicus* or *B. indicus* × *B. taurus* cattle (Beatty *et al.*, 2004, 2006; Cartwright, 1955; Carvalho *et al.*, 1995; De Azevedo *et al.*, 2005; Finch, 1985; Hammond *et al.*, 1996; McDowell *et al.*, 1953; Prayaga and Henshall, 2005; Skinner and Louw, 1966). Cattle with dark or black hides tend to be more impacted (Busby and Loy, 1996; Hungerford *et al.*, 2000). Common perception is that a currently compromised immune systems and/or prior cases of pneumonia (Brown-Brandl *et al.*, 2006a) can cause an increased impact to hot weather. Animals that approach finishing weight or have more fat cover (Brown-Brandl *et al.*, 2006a) were reported to have a higher stress level under hot conditions. Animals that have not had adequate time to acclimate to the hot weather are more impacted by heat stress than those not acclimated (Robinson *et al.*, 1986). The last factor that has been documented to increase an animal's susceptibility is an excitable temperament (Brown-Brandl *et al.*, 2006a).

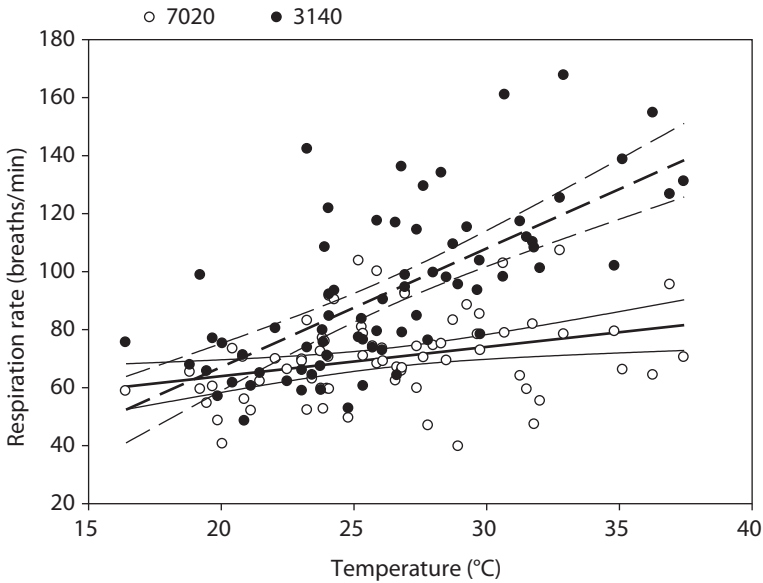

Figure 10.2. Respiration rate response of two feedlot heifers over a 3-month summer period exposed to a variety of environmental conditions. The white points represent the response of heifer 7,020, a Charolais heifer. The black points represent heifer 3,140, a dark red Bos taurus heifer. The two animals were under the same management scheme and their respiration rates were recorded at the same time (from Brown-Brandl and Jones, 2011). The 95% confidence intervals demonstrate the responses are different above a temperature above 22.5 °C.

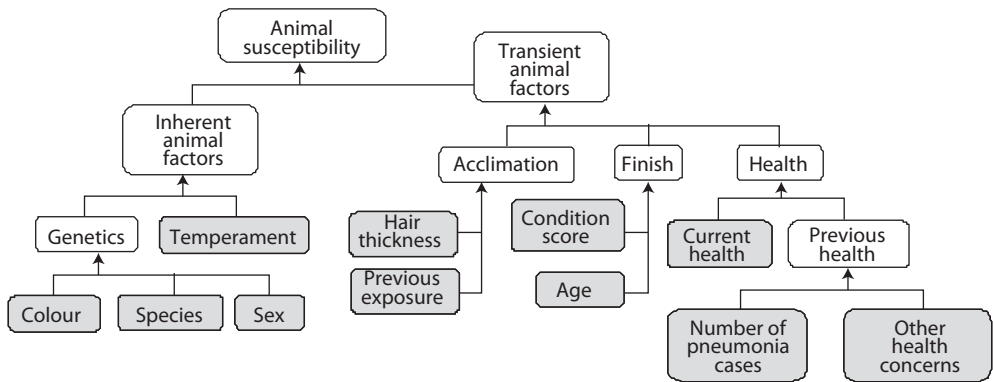

Figure 10.3. Schematic of animal susceptibility used to develop a cattle susceptibility model (Brown-Brandl and Jones, 2011). The model consists of eight unique Fuzzy Inference System models (indicated by the white boxes) and 11 user inputs (indicated by the gray boxes) to predict an individual animal's susceptibility to heat stress.

*B. indicus* cattle are more tolerant to hot ambient conditions than *B. taurus* breeds and tolerance of cross-bred falls between the *B. indicus* and *B. taurus* cattle. This heat tolerance results from both a lower metabolic rate and physiological differences that aid heat loss (Hansen, 2004). *B. indicus* cattle have a greater surface area to mass ratio (Shido, 2002), with a thinner and less dense hair coat (Finch *et al.*, 1984) than *B. taurus* cattle. It also appears that *B. indicus* have a mechanism to increase blood flow to the skin's surface to dissipate heat more easily (Hansen, 2004). These physiological differences would increase the sensible heat loss from the animals, therefore, delaying the onset of latent heat loss (sweating and panting). This has been documented by the differing responses of *B. indicus* and *B. taurus* cattle to heat load as measured by respiration rate and body temperature (Gaughan *et al.*, 1999).

Dark-hided cattle seem to be more prone to heat stress than light-hided cattle. Dark-hided animals absorb more radiant heat from the environment (Finch *et al.*, 1984; Stewart, 1953). The more added environmental heat the animal absorbs the more difficult it is to maintain thermal balance, resulting in higher stress. Brown-Brandl *et al.* (2006b) found that black (Angus) or dark red (MARC III) heifers had higher respiration rates than either the tan (Gelbvieh) or white (Charolais) heifers. This increased susceptibility to heat stress leads to an increased vulnerability during an extreme event and results in decreased production during periods of hot weather (Hansen, 1990). Two producer surveys revealed a larger death loss from black-hided animals (Busby and Loy, 1996b; Hungerford *et al.*, 2000) during extreme events in 1995 and 1999 in the Midwestern region of the US.

There is some evidence to suggest that feedlot heifers are slightly more susceptible to heat stress than steers (Busby and Loy, 1996). This effect may be a result of heifers in estrous eliciting mounting or riding behavior with the other heifers in the same pen. Research has shown that this 'mounting' behavior does not diminish in hot weather (Brown-Brandl *et al.*, 2006b). This extra activity increases an animal's heat production. Under normal circumstances, this extra metabolic heat is easily dissipated; however, under high environmental temperatures this extra metabolic heat becomes an added stressor. Feedlots typically feed MGA (melengestrol acetate) to feedlot heifers, which suppress the estrous cycle (Horton *et al.*, 1981). Busby and Loy (1996) found death losses in feedlot pens fed MGA was about half the death losses in pens not fed MGA (3.8 vs. 6.2%).

The temperament or excitability of an individual animal influences the animal's growth and performance. Brown-Brandl *et al.* (2006a) found that heifers with a temperament score (a visual assessment of behavior while the animals are confined within the scale) over 1.5 (on a 5-point scale) had a small increase in respiration rate at temperatures higher than 22.5 °C. Data is lacking from animals with a high temperament score (3 or higher), where a greater response would be anticipated. The most probable explanation to this difference is that excitable animals (animal with a high temperament score) react to sudden or intermittent stimuli (Lanier *et al.*, 2000). This reaction would be associated with increased activity, which in turn causes an increase in heat production (McDonald *et al.*, 1988).

As cattle become acclimated to a hot environment, several changes occur to both minimize heat production and maximize heat loss. The first response of cattle exposed to high temperatures is

a reduction in feed intake (Brown-Brandl *et al.*, 2003, 2005a). This reduction in feed intake has two consequences that reduce heat production. First, the reduction in feed intake decreases the heat produced from the heat of digestion. Second, a long-term effect results from a prolonged reduction in feed intake that reduces the size of the metabolically activity organs, thus reducing fasting heat production (Ferrell *et al.*, 1986; Koong *et al.*, 1982, 1985). Heat production also declines due to the decreased secretion of thyroid hormone (Al-Haidary *et al.*, 2001).

Cattle also maximize their heat loss when chronically exposed to high temperatures. Cattle coats become lighter in color and less dense when the animals are exposed to hot weather and high solar radiation (Stewart and Brody, 1954). Coat depth and density and hair thickness and length varies immensely with breed and acclimation to various weather conditions (Berman, 2004). Blaxter and Wainman (1964) reported coat depths between 4 and 31 mm. Less dense and thinner hair coats not only maximize sensible heat loss, but also maximize the latent heat loss through the skin (Gebremedhin and Wu, 2001; Gebremedhin *et al.*, 2007; Turnpenny *et al.*, 2000).

The effect of age and condition score (fat cover) is two-fold. First, cattle with a high condition score (thick layer of fat directly beneath the skin) have more difficulty transferring heat to the surface of the skin where it can be dissipated (Berman, 2004; Turnpenny *et al.*, 2000). Cattle with a condition score of 9 (out of a 1-9 scale) were the most impacted by increasing temperature (Brown-Brandl *et al.*, 2006a). This increased stress at high ambient temperatures increases respiration rate and puts these animals at increased risk during an extreme event (Busby and Loy, 1996) Second, cattle entering the feedlot, which typically have a lower condition score, can also be at risk for heat stress. This is the result of several stressors and their interactions. The more concurrent stressors imposed on an animal, the greater the impact on the animal. As cattle move into a feedlot, they are subjected to the stress of transporting, changing diets, adapting to different surroundings, establishing social ranking, etc. In addition, cattle entering the feedlot are more prone to developing bovine respiratory disease (Snowder *et al.*, 2006). Also, cattle entering the feedlot may have been exposed to endophyte-infected tall fescue. Endophyte-infected grass contains a toxin which is a vasoconstrictor. A vasoconstrictor is a substance which prevents the blood vessels on the surface of the skin from vaso dilating and thus inhibits both sensible and latent heat loss from the skin surface (Al-Haidary *et al.*, 2001; Browning and Leite-Browning, 1997).

Both current and previous health status influences the stress level the animal experiences during summertime conditions. It has been shown that cattle that have previously been treated for pneumonia have an increased respiration rate (Brown-Brandl *et al.*, 2006a). Pneumonia can cause lung lesions, which reduce the overall lung capacity (Johnston *et al.*, 1998).

## **10.5 Animal management strategies**

Researchers have been looking for management options to reduce heat stress for many years. Management strategies can impact not only the animals' response to heat but also the overall economics of the production system. Management strategies can also have unintended consequences. Figure 10.4 summarizes different management strategies that have been investigated. The management strategies can be broken down into 4 sub-categories: feed (Brosh

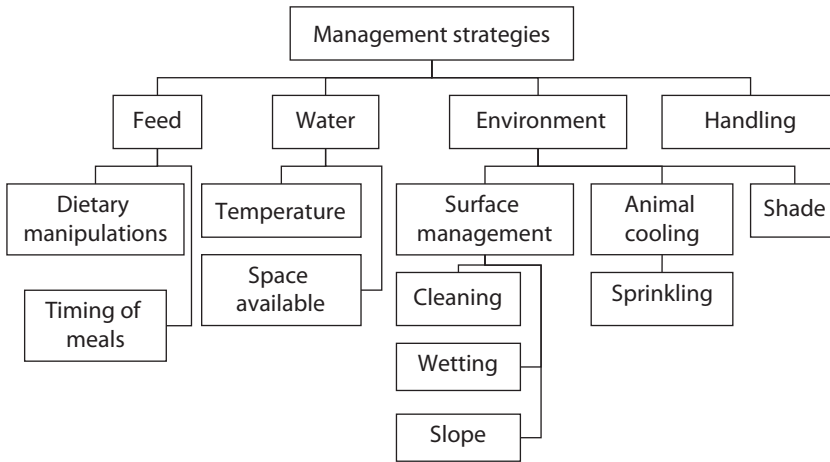

Figure 10.4. Summary of management options to reduce heat stress in feedlot cattle. The options must be carefully considered, as each management option that has the potential of reducing heat stress is also associated with one or more negative aspects (increase labor, slower growth, increase odor generation, etc.).

*et al.*, 1998; Holt *et al.*, 2004; Mader *et al.*, 2002; MLA, 2006c), water (Beck *et al.*, 2000; Bicudo and Gates, 2002), environment modifications (Blackshaw and Blackshaw, 1994a; Garner *et al.*, 1989; Mader *et al.*, 2007) and handling changes (Brown-Brandl *et al.*, 2010b; Mader *et al.*, 2007).

### 10.5.1 Diet and feeding

Feeding contributes significantly to the total heat production of the animal (Blaxter and Boyne, 1979). In addition, heat related problems are complicated by feeding high-energy grain diets. These diets contribute to a rise in heat production, which, under typical management, coincide with the diurnal temperature cycle (Brosh *et al.*, 1998). Holt *et al.* (2004), showed that both limit feeding and an altered feeding schedule (access to feed between 16:00-08:00 hour) reduced body temperature during the day when compared to *ad libitum* fed animals. While these strategies have an impact on the animals exposed to hot weather, similar studies have shown little overall difference in animal performance (Mader and Davis, 2004). The lack of differences in performance is due to the potential for compensation by the animals.

Not only does feeding time influence an animal's metabolism, but also diet formulation can vary the amount of feed consumed and the heat production from its digestion (Blaxter, 1989). Various approaches have been taken in summertime diet formulation for feedlot cattle (MLA, 2006c). Different feed ingredients produce different amounts of energy when digested; this is known as heat increment (HI). The lowest HI component of a diet is fat, followed by carbohydrates and then proteins (Blaxter, 1989). Some summertime rations incorporate more fats and oils. However, cattle fed this type of highly digestible, high-energy ration can have irregular feeding patterns, periods of over eating followed by periods of low feed intake. This irregular feed intake can lead to acidosis



and more severe health related issues. Another approach to summertime diets is to increase the roughage in the diet. This may help maintain cattle at a constant rate of feed intake (MLA, 2006c).

### **10.5.2 Water**

Management of the water availability in the feedlot is critical especially during times of extreme summertime conditions. Beef cattle within the feedlot consume between 22 and 78 liters of water per day, depending of the weight of the animal, the diet fed and the ambient temperature (Gaughan *et al.*, 2010; Parish and Rhinehart, 2008; Parker and Brown, 2003; Winchester and Morris, 1956). For a feedlot in Texas, Parker *et al.* (2000) reported daily water consumption of 34.1 liters per animal during winter and 39.0 liters per animal during summer. Gaughan *et al.* (2010) reported water consumption up to 71.2 liters per animal during a heat wave for unshaded animals. Water consumption allows the animal to maintain body temperature by increasing latent heat loss either by sweating or panting, while maintaining hydration. From a thermodynamics point of view, drinking relatively cool water helps dissipate excess body heat. Some studies have reported increased feed intake, weight gain and energy utilization when the drinking water was maintained at 18 °C compared to a water temperature of 32 °C (Lofgreen *et al.*, 1975). However, Savage *et al.* (2008) found sheep preferred drinking warmer water when exposed to hot ambient conditions. The Meat and Livestock Australia (MLA, 2006c) recommends a minimum of 25 mm of water space/animal in the feedlot and 75 mm/animal under hot conditions. During extreme summertime conditions, water supply may be limited due to the increased demand for water from different animals and possibly other farm uses as well. To ensure adequate water to all pens, water flow rates need to be checked. During summertime conditions, the system needs to deliver a minimum of 1.1% of body weight per hour (roughly 5 liters/hour for a 450 kg animal). Ideally the water system should be capable of delivering the entire day's needs within a 4 to 8 hour period (Mader, 2000). Water may also become limiting due to dominance behavior as during periods of hot weather animals tended to stand in large groups around the water tanks (Brown-Brandl *et al.*, 2006b)

### **10.5.3 Surface-location concerns**

Pen location, slope and surface maintenance all play critical roles in the micro-climate surrounding the animals. The direction of a feedlot slope affects the angle and the amount of solar radiation the cattle receive. In the northern hemisphere, the south-, southwest- and west-facing lots receive the most intense solar radiation. A producers' survey, taken after a severe heat wave event in central US, revealed pen orientation affected the number of cattle deaths. All south-facing lots surveyed lost cattle during the event. Southwest- and west-facing lots had the highest death losses, while southeast- and east-facing lots had the least death loss (Busby and Loy, 1996). The locations of all permanent structures or trees need to be considered when placing cattle in a feedlot, as these structures will act as wind break. While these windbreaks are beneficial to the animals in the winter (Mader, 2003) these wind breaks are detrimental during the summertime as they stop the wind from cooling the cattle on hot days (Mader *et al.*, 1997). While it would not be practical to change the orientation of a feedlot surface or remove all wind breaks, a producer could place more heat-tolerant cattle in those pens in the summer, or select different management strategies – such as added shade or sprinkle cooling in those pens.

The surface of the feedlot pen plays an important role in overall impact of hot weather on feedlot cattle. The temperature of the unshaded feedlot surface can easily exceed 55 °C on a hot sunny day in a feedlot (Brown-Brandl *et al.*, 2010a). This high soil temperature adds to the overall heat load of the animal. Experiments have been conducted to reduce this high soil temperature by applying water to the feedlot surface. Applying water either in the morning or afternoon significantly reduced the soil temperature throughout the day (Mader *et al.*, 2007). Applying water to the soil has an added benefit, beyond cooling the soil surface, it increases the thermal conductivity of the soil (Campbell *et al.*, 1994; Sepaskhah and Boersma, 1979), thus, increasing conductive heat transfer between the animals and the soil.

Maintenance of the feedlot surface is also critical to animal well-being, heat stress concerns and odor generation. Manure has a greater water holding capacity than soil (Khaleel *et al.*, 1981). This can have serious consequences during and after a rain event, as wet manure-soil mixture can form a dam thus preventing water from draining out of the pen. Therefore, surface maintenance is a relatively simple way to ensuring the pens stay as dry as possible.

### 10.5.4 Sprinkle cooling

Another management strategy used in some feedlots is sprinkling or wetting the animals. To maximize the added latent heat loss when sprinkling cattle, the animals' hair coat must be saturated to the skin surface and then allowed to dry completely. While the cool water has a small convective heat loss component, the real benefit comes from the evaporation of water from the skin surface. The benefits to sprinkled cattle include: lowering body temperature, decreasing respiration rate and maintaining feed consumption (Garrett, unpublished data; Gaughan *et al.*, 2004). The size of the droplets influences the effectiveness of the sprinkling treatment. A fine mist has a difficult time saturating the hair coat and the droplets tend to set on top of the hair coat. If this happens, the water forms a barrier which reduces heat transfer. Therefore, misting does not have the same impact on cattle as sprinkling (Mitloehner *et al.*, 2001) and can actually have a negative effect.

### 10.5.5 Shade

Shade is one of the most common management strategies. Artificial shade can be made up of many different materials with various levels of effectiveness (Bond *et al.*, 1954; Eigenberg *et al.*, 2007; Kelly and Bond, 1958). The most effective shade materials are solid metal shade with insulation; however, with higher initial cost and more maintenance required, other materials need to be considered. For example, shade structures constructed of snow fence material provide only about 30-50% effectiveness; however, it can substantially reduce the heat load under extreme conditions (Eigenberg *et al.*, 2007). Another advantage of snow fence material is the smaller wind and snow load, which reduces the cost of a structure. The need for shade is also dependent on the intensity of the summer weather in the area where the feedlot is located (Figure 10.4) (Garrett, unpublished data). Shade has been shown to improve performance of feedlot animals in areas with more than 700 hours/year above 29.4 °C. In areas with 500-700 hours/year the effects are variable and depend on the year. Factors to be considered in shade design include area of shadow, location of shade, orientation of the shade structure and type of material to be used (MLA, 2006a).

Ventilation of a shade structure must be considered. The natural ventilation under a shade structure is influenced by both wind and thermal buoyancy (Albright, 1990). Thermal buoyancy is important during times of still wind conditions. Thermal buoyancy is critical especial in the most extreme hot weather conditions because in addition to high ambient air temperature conditions would also include high solar radiation (little or no cloud cover) and little or no wind. In those cases, most animals will seek shade (Schütz *et al.*, 2009a,b). The animals standing under the structure heat the air. The hot air rises and escapes the structure thus pulling in fresh cooler air. The porous material, such a shade cloth or snow fence, allows air to pass through, thus allowing hot air to escape. Solid shade structures must include a route for hot air to escape. This could be accomplished using a ridge vent in a gabled roof, or a completely open front in the case of a mono-slope roof.

Providing shade for animals can reduce their radiant heat load by 30 or more (Bond *et al.*, 1967). Providing shade for feedlot cattle reduces respiration rate at the peak of the day in all environments and body temperature in moderate to hot environments (Brown-Brandl *et al.*, 2005b). Feed intake is maintained at a higher level in animals that have access to shade in hot weather (Brown-Brandl *et al.*, 2005b). However, the impact of shade on animal performance is varied (Blackshaw and Blackshaw, 1994b), most likely due to different environmental extremes (Garrett, unpublished data). Shades have been shown to significantly reduce the death losses during an extreme event (Busby and Loy, 1996). Shade has been shown to have a positive effect on performance in areas that receive on average over 700 hrs above the threshold of 29.4 °C and have a mix effect in areas that receive between 500-700 hrs of temperatures above the threshold. However in areas that typically receive less than 500 hrs of temperatures above 29.4 °C will not normally observe an increase in performance with the addition of shades (Figure 10.5).

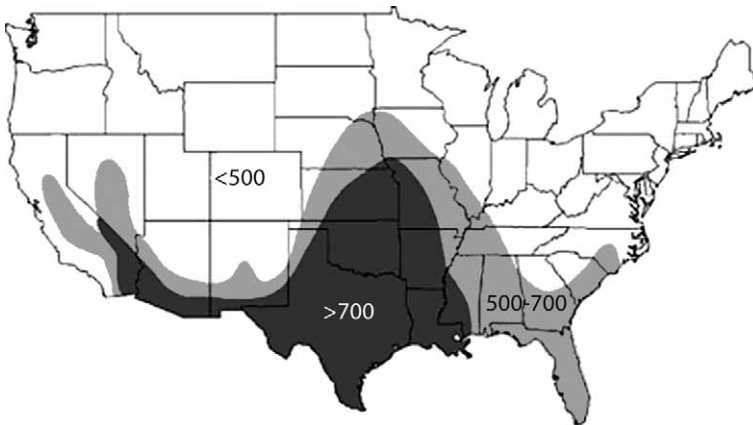

Figure 10.5. Areas of the continental United States with three thresholds of hours above 29.4 °C. Producers located in both shaded areas would benefit from providing shade to feedlot cattle. Data was taken from Garrett (unpublished data).

### 10.5.6 Handling

The animal activity associated with handling and transporting cattle causes an increase in body temperature (Brown-Brandl *et al.*, 2010b; Fazio and Ferlazzo, 2003; Mader *et al.*, 2005) due to the heat produced from the muscle activity. The extent of the rise in body temperature is affected by the distance the animals are moved, ambient conditions (Mader *et al.*, 2005) and the temperament score of the individual animal (Brown-Brandl, 2008). Mader *et al.* (2005) found the time for the body temperature to return to normal ranged from 1 to 3.5 hours depending on the environmental conditions (longer recovery in winter than spring). Figure 10.6 illustrates the rise in body temperature associated with moving animals through a handling facility, in addition to the effect of temperament score of the animal. The example shown in Figure 10.6a is from a heifer with a temperament score of 4 (on a 1 to 5 scale), while the example shown in Figure 10.6b is from a heifer with a temperament score of 2. Under summertime conditions, the impact on heat load from moving animals is least when completed in the early morning and should to be avoided on days that are forecasted to be extremely hot. During periods of hot temperatures, cattle's body temperature lags environmental temperature between 1 and 5 hours (Brown-Brandl *et al.*, 2005b;

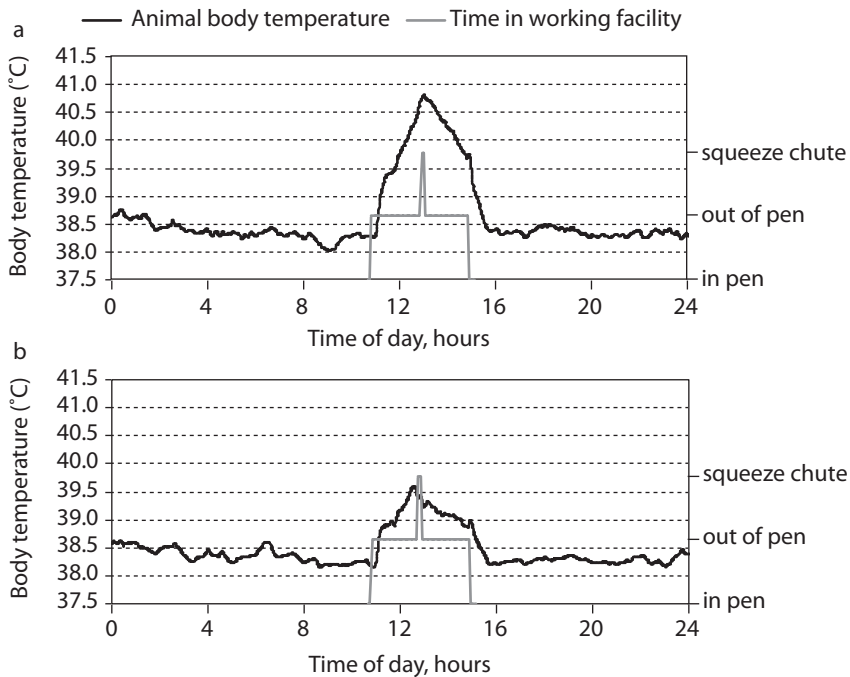

Figure 10.6. The effects of moving animals and temperament score on the body temperature of feedlot heifers. Both heifers were run through the working facility on the same day and time. Actual time out of the pens is shown using the grey line: 0 in the pen, 1 out of the pen, 2 in the squeeze chute. (a) Animal 5517 temperament score was 4 on a 1 to 5 scale (where 1 was calm and 5 was very agitated and aggressive). (b) Animal 5652 temperament score of 2 on the same 1 to 5 scale. Unpublished data Brown-Brandl.

Hahn, 1989; Hahn *et al.*, 1999, 2003; Scott *et al.*, 1983), therefore if animals are processed in the evening after sundown the increase body temperature due to handling would coincide with the maximum diurnal body temperature (Mader, 2000).

### 10.5.7 Application of management strategies

While many management strategies have been researched, all have both positive and negative aspects associated with them. The advantage for all of the management options is that they lower heat stress, but some have greater impact than others. The disadvantages include poorer performance of the animals in the case of changing feeds, increased labor or different work schedule for employees (timing of meals and cleaning) and increased odor generation with the addition of water on the feedlot surface. While decisions are always based on cost to benefit ratios, the costs and benefits are sometimes difficult to estimate and often times include costs other than monetary. For example the cost of changing the timing of the meals includes not only the cost of the extra labor, but also worker dissatisfaction, a cost the feedlot operator cannot always afford. Another example is the increased odor generation associated with sprinkle cooling, which can affect the people who live in the vicinity of the feedlot. Depending of the location of the feedlot, this may have a particularly high cost. Therefore, choosing a single correct management strategy for an entire feedlot is very difficult.

The interactive nature of the three components (environment, animal susceptibility, management) would make this a candidate for precision animal management (Figure 10.7). Precision animal management in this sense is applying the correct level of management to different animals. In order to apply precision animal management, the first step involves assessing individual animals for susceptibility to heat stress. The second step is to separate animals into groups with similar

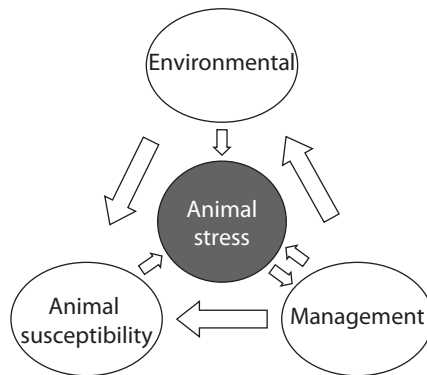

Figure 10.7. A schematic illustrating the three components of animal stress (environment, animal susceptibility and management) and their interactive nature. Some management schemes influence the micro-environmental conditions (shade, sprinkle cooling) and can impact animal susceptibility (different dietary components). Ultimately, in a best management practice, the animal heat stress level should provide feedback to the producer to make management decisions.

susceptibilities. Finally, management strategies are selected that will work best for that group of animals. Application of management strategies based on the animals' needs maximizes benefits while minimizing cost.

### 10.6 Conclusions

This chapter has highlighted the economic consequences of heat stress and described the three components of heat stress in feedlot cattle: animal susceptibility, environmental conditions and some current management options. Precision animal management offers a method to provide the most effectively management using the fewest resource, knowledge of all three factors are they interactions are needed. While, there have been focused efforts on each of the individual components little research has been completed on the interactions of these three components. The interaction of these three components is very difficult to determine experimentally due to the complex nature and the endless combinations of factors. However, with the continued research, both live animal experimentation and model simulations, into the interactions of these three components these precision animal management techniques could become a reality in the future.

### Disclaimer

The USDA is an equal opportunity provider and employer. The mention of trade names of commercial products in this article is solely for the purpose of providing specific information and does not imply recommendation or endorsement by the USDA.

### References

- Al-Haidary, A., Spiers, D.E., Rottinghaus, G.E., Garner, G.B. and Ellersieck M.R., 2001. Thermoregulatory ability of beef heifers following intake of endophyte-infected tall fescue during controlled heat challenge. *Journal of Animal Science* 79: 1780-1788.
- Albright, L.D., 1990. Environment control for animals and plants. American Society of Agricultural Engineers, St. Joseph, MI, USA.
- AMS, 1989. Glossary of meteorology. 5<sup>th</sup> ed. American Meteorological Society, Boston, MA, USA.
- Beatty, D., Barnes, A., Pethick, D.W., Taylor, E. and Dunshea, F.R., 2004. *Bos indicus* cattle can maintain feed intake and fat reserves in response to heat stress better than *Bos taurus* cattle. *Journal of Animal and Feed Sciences* 13 (Suppl. 1): 619-622.
- Beatty, D.T., Barnes, A., Taylor, E., Pethick, D., McCarthy, M. and Maloney, S.K., 2006. Physiological responses of *Bos taurus* and *Bos indicus* cattle to prolonged, continuous heat and humidity. *Journal of Animal Science* 84(4): 972-985.
- Beck, J., Katzchke, D. and Steingass, H., 2000. Heated drinking water for dairy cows. *agrartechnische Forschung* 6(4): E97-E101.
- Berman, A., 2004. Tissue and external insulation estimates and their effects on prediction of energy requirements and of heat stress. *Journal of Dairy Science* 87: 1400-1412.
- Bicudo, J.R. and Gates, R.S., 2002. Water consumption, air and water temperature issues related to portable water systems for grazing cattle. ASABE Meeting Paper No. 024052. American Society of Agricultural Engineers, St. Joseph, MI, USA.

- Blackshaw, J.K. and Blackshaw, A.W., 1994a. Heat stress in cattle and the effect of shade on production and behaviour: a review. *Australian Journal of Experimental Agriculture* 34(2): 285-295.
- Blackshaw, J.K. and Blackshaw, A.W., 1994b. Heat stress in cattle and the effect of shade on production and behaviour: a review. *Australian Journal of Experimental Agriculture* 34: 285-295.
- Blaxter, K., 1989. *Energy metabolism in animals and man*. Cambridge University Press, Cambridge, UK.
- Blaxter, K.L. and Boyne, A.W., 1979. The estimation of the nutritive value of feeds as energy sources for ruminants and the derivation of feeding systems. *Journal of Agricultural Science* 90: 47-68.
- Blaxter, K.L. and Wainman, F.W., 1964. The effect of increase air movement on the heat production and emission of steers. *Journal of Agricultural Science* 62: 207-214.
- Bond, T.E., Kelly, C.F. and Ittner, N.R., 1954. Radiation studies of painted shade materials. *Agricultural Engineering* 35: 389-392.
- Bond, T.E., Kelly, C.F., Morrison, S.R. and Pereira, N., 1967. Solar, atmospheric and terrestrial radiation received by shaded and unshaded animals. *Transactions of the American Society of Agricultural Engineers* 10: 622-627.
- Brosh, A., Aharoni, Y., Degen, A.A., Wright, D. and Young, B.A., 1998. Effects of solar radiation, dietary energy and time of feeding on thermoregulatory responses and energy balance in cattle in a hot environment. *Journal of Animal Science* 76: 2671-2677.
- Brown-Brandl, T.M., 2008. Heat stress in feedlot cattle. *CAB Reviews: Perspectives in Agriculture, Veterinary Science, Nutrition and Natural Resources* 3: 1-14.
- Brown-Brandl, T.M., Eigenberg, R.A., Hahn, G.L., Nienaber, J.A., Mader, T.L., Spiers D.E. and Parkhurst, A.M., 2005a. Analyses of thermoregulatory responses of feeder cattle exposed to simulated heat waves. *International Journal of Biometeorology* 49: 285-296.
- Brown-Brandl, T.M., Eigenberg, R.A. and Nienaber, J.A., 2006a. Heat stress risk factors of feedlot heifers. *Livestock Science* 105: 57-68.
- Brown-Brandl, T.M., Eigenberg, R.A. and Nienaber, J.A., 2010a. Benefits of providing shade to feedlot cattle of different breeds. ASABE Meeting Paper No. 1009517. American Society of Agricultural Engineers, St. Joseph, MI, USA.
- Brown-Brandl, T.M., Eigenberg, R.A. and Nienaber, J.A., 2010b. Water spray cooling during handling of feedlot cattle. *International Journal of Biometeorology*. 54(6): 609-616.
- Brown-Brandl, T.M., Eigenberg, R.A., Nienaber, J.A. and Hahn G.L., 2005b. Dynamic response indicators of heat stress in shaded and non-shaded feedlot cattle, Part 1: Analyses of indicators. *Biosystems Engineering* 90(4): 451-462.
- Brown-Brandl, T.M. and Jones, D.D., 2011. Feedlot cattle susceptibility to heat stress: an animal-specific model. *Transactions of the ASABE* 54(2): 583-598.
- Brown-Brandl, T.M., Nienaber, J.A., Eigenberg, R.A., Hahn, G.L. and Freetly, H.C., 2003. Thermoregulatory responses of feeder cattle. *Journal of Thermal Biology* 28: 149-157.
- Brown-Brandl, T.M., Nienaber, J.A., Eigenberg, R.A., Mader, T.L., Morrow, J.L. and Dailey, J.W., 2006b. Comparison of heat tolerance of feedlot heifers of different breeds. *Livestock Science* 105: 19-26.
- Browning, J.R. and Leite-Browning, M.L., 1997. Effect of ergotamine and ergonovine on thermal regulation and cardiovascular function in cattle. *Journal of Animal Science* 75(1): 176-181.
- Busby, D. and Loy, D., 1996. Heat stress in feedlot cattle: producer survey results. ASABE Meeting Paper No. A.S. Leaflet R1348. American Society of Agricultural Engineers, St. Joseph, MI, USA.
- Campbell, G.S., Jungbauer Jr., J.D., Bidlake, W.R. and Hungerford, R.D., 1994. Predicting the effect of temperature on soil thermal conductivity. *Soil Science* 158(5): 307-313.



- Cartwright, T.C., 1955. Responses of beef cattle to high ambient temperatures. *Journal of Animal Science* 14(2): 350-362.
- Carvalho, F.A., Lammoglia M.A., Simoes M.J. and Randel R.D., 1995. Breed affects thermoregulation and epithelial morphology in imported and native cattle subjected to heat stress. *Journal of Animal Science* 73(12): 3570-3573.
- De Azevedo, M., De Pires, M.F.A., Satumino, H.M., Lana, A., Sampaio, I.B.M., Monteiro, J.B.N. and Morato, L.E., 2005. Estimation of upper critical levels of the temperature-humidity index for 1/2, 3/4 e 7/8 lactating Holstein-Zebu dairy cows. *Revista Brasileira de Zootecnia* 34(6): 2000-2008.
- Eigenberg, R.A., Brown-Brandl, T.M. and Nienaber, J.A., 2007. Shade material evaluation using a cattle response model. ASABE Meeting Paper No. 074082. American Society of Agricultural Engineers, St. Joseph, MI, USA.
- Eigenberg, R.A., Brown-Brandl, T.M., Nienaber, J.A. and Hahn, G.L., 2005. Dynamic response indicators of heat stress in shaded and non-shaded feedlot cattle, Part 2: predictive relationships. *Biosystems Engineering* 91(1): 111-118.
- Fazio, E. and Ferlazzo, A., 2003. Evaluation of stress during transport. *Verinary Research Communications* 27 (Supp. 1): 519-524.
- Ferrell, C.L., Koong, L.J. and Nienaber, J.A., 1986. Effect of previous nutrition on body composition and maintenance energy costs of growing lambs. *British Journal of Nutrition* 56: 595-605.
- Finch, V.A., 1985. Comparison of non-evaporative heat transfer in different cattle breeds. *Australian Journal of Agricultural Research* 36: 497-508.
- Finch, V.A., Bennett, I.L. and Homes, C.R., 1984. Coat colour in cattle: effects on thermal balance, behaviour and growth and relationship with coat type. *Journal of Agricultural Science* 102: 141-147.
- Garner, J.C., Bucklin, R.A., Kunkle, W.E. and Nordstedt, R.A., 1989. Sprinkled water and fans to reduce heat stress of beef cattle. *Applied Engineering in Agriculture* 5(1): 99-101.
- Gaughan, J.B., Davis, M.S. and Mader, T.L., 2004. Wetting and the physiological responses of grain-fed cattle in a heated environment. *Australian Journal of Agricultural Research* 55(3): 253-260.
- Gaughan, J.B., Holt, S.M., Hahn, G.L., Mader, T.L. and Eigenberg, R.A., 2000. Respiration rate – is it a good measure of heat stress in cattle? *Journal of Animal Science* 13: 329-332.
- Gaughan, J.B., Mader, T.L., Holt, S.M. and Lisle, A., 2008. A new heat load index for feedlot cattle. *Journal of Animal Science* 86: 226-234.
- Gaughan, J.B., Mader, T.L., Holt, S.M., Josey, M.J. and Rowan, K.J., 1999. Heat tolerance of Boran and Tuli crossbred steers. *Journal of Animal Science* 77: 2398-2405.
- Gaughan, J.B., Mader, T.L., Holt, S.M., Sullivan, M.L. and Hahn, G.L., 2010. Assessing the heat tolerance of 17 beef cattle genotypes. *International Journal of Biometeorology* 54: 617-627.
- Gebremedhin, K.G. and Wu, B., 2001. A model of evaporative cooling of wet skin surface and fur layer. *Journal of Thermal Biology* 26(6): 537-545.
- Gebremedhin, K.G., Hillman, P.E., Lee, C.N. and Collier, R.J., 2007. Sweating rate of dairy cows under shade and sunny environments. ASABE Meeting Paper No. 074083. American Society of Agricultural Engineers, St. Joseph, MI, USA.
- Hahn, G.L., 1989. Body temperature rhythms in farm animals – a review and reassessment relative to environmental influences. In *Proceedings of the 11<sup>th</sup> ISB Congress*, SPB Academic Publishing, the Hague, the Netherlands 325-337.
- Hahn, G.L., 1999. Dynamic responses of cattle to thermal heat loads. *Journal of Animal Science* 77 Suppl 2: 10-20.



- Hahn, G.L. and Mader, T.L., 1997. Heat waves in relation to thermoregulation, feeding behavior and mortality of feedlot cattle. In Proceeding of the 5<sup>th</sup> International Livestock Environment Symposium. American Society of Agricultural Engineers, St. Joseph, MI, USA, pp. 563-571.
- Hahn, G.L., Mader, T.L. and Eigenberg, R.A., 2003. Perspectives on development of thermal indices for animal studies and management. In: Lacetera, N., Bernabucci, U., Khalifa, H.H., Ronchi, B. and Nardone, A. (eds.) Interactions between climate and animal production. EAAP Technical Series no. 7. Wageningen Academic Publishers, Wageningen, the Netherlands, pp. 31-44.
- Hahn, G.L., Mader, T.L., Gaughan, J.B., Hu, Q. and Nienaber, J.A., 1999. Heat waves and their impacts on feedlot cattle. In: De Dear, R. and World Meteorological Organization and United Nations Environment Programme and Macquarie University (eds.) International congress on biometeorology & international conference on urban climatology, ICB11.1. World Meteorological Organization in association with the United Nations Environment Programme and Macquarie University, Geneva, Switzerland.
- Hammond, A.C., Olson, T.A., Chase Jr., C.C., Bowers, E.J., Randel, R.D., Murphy, C.N., Vogt, D.W. and Tewolds, A., 1996. Heat tolerance in two tropically adapted *Bos taurus* breeds, Senepol and Romosinuano, compared with Brahman, Angus and Hereford cattle in Florida. *Journal of Animal Science* 74: 295-303.
- Hansen, P.J., 1990. Effects of coat colour on physiological responses to solar radiation in Holsteins. *Veterinary Record* 127: 333-334.
- Hansen, P.J., 2004. Physiological and cellular adaptations of Zebu cattle to thermal stress. *Animal Reproduction Science* 82-83: 349-360.
- Holt, S.M., Gaughan, J.B. and Mader, T.L., 2004. Feeding strategies for grain-fed cattle in a hot environment. *Australian Journal of Agriculture Research* 55: 719-725.
- Horton, G.M.J., Manns, J.G., Nicholson, H.H. and Harrop, G.A., 1981 Behavioral activity, serum progesterone and feedlot performance of heifers fed melengestrol acetate and monensin. *Canadian Journal of Animal Science* 61: 695-702.
- Hubbard, K.G., Stookbury, D.E., Hahn, G.L. and Mader, T.L., 1999a. A climatological perspective on feedlot cattle performance and mortality related to the temperature-humidity index. *Journal of Production Agriculture* 12(4): 650-653.
- Hubbard, K.G., Stookbury, D.E., Hahn, G.L. and Mader, T.L., 1999b. A climatological perspective on feedlot cattle performance and mortality related to the temperature-humidity index. *Journal of Production Agriculture* 12(4): 650-653.
- Hungerford, L.L., Buhman, M.J., Dewell, R.D., Mader, T.L., Griffin, D., Smith, D.R. and Nienaber, J.A., 2000. Investigation of heat stress mortality in four midwest feedlots. In: Proceeding of the 9<sup>th</sup> Symposium of Veterinary Epidemiology and Economics, pp. 430-433.
- Kelly, C.F. and Bond T.E., 1958. Effectiveness of artificial shade materials. *Agricultural Engineering* 39: 758-764.
- Khaleel, R., Reddy K.D. and Overcash M.R., 1981. Changes in soil physical properties due to organic waste applications: a review. *Journal of Environmental Quality* 10(2): 133-141.
- Koong, L.J., Ferrell, C.L. and Nienaber, J.A., 1985. Assessment of interrelationships among levels of intake and production, organ size and fasting heat production in growing animals. *Journal of Nutrition* 115: 1383-1390.
- Koong, L.J., Nienaber, J.A., Pekas, J.C. and Yen, J.T., 1982. Effects of plane of nutrition on organ size and fasting heat production in pigs. *Journal of Nutrition* 112: 1638-1642.
- Johnston, I.D.A., Strachan, D.P. and Anderson, H.R., 1998. Effect of pneumonia and whooping cough in childhood on adult lung function. *New England Journal of Medicine* 338(9): 581-587.

- Lanier, J.L., Grandin, T., Green, R.D., Avery, D. and McGee, K., 2000. The relationship between reaction to sudden, intermittent movements and sounds and temperament. *Journal of Animal Science* 78: 1467-1474.
- LCI., 1970. Patterns of transect losses. Livestock Conservation, Inc., Omaha, NE, USA.
- Lofgreen, G.P., Givens, R.L., Morrison, S.R. and Bond, T.E., 1975. Effect of drinking water temperature on beef cattle performance. *Journal of Animal Science* 40(2): 223-229.
- Mader, T.L., 2000. Environmental stress in confined beef cattle. *Journal of Animal Science* 81 (E. Suppl. 2): E110-E119.
- Mader, T.L., 2003. Environmental stress in confined beef cattle. *Journal of Animal Science* 81(14): E110-E119.
- Mader, T.L. and Davis, M.S., 2004. Effect of management strategies on reducing heat stress of feedlot cattle: Feed and water intake. *Journal of Animal Science* 82: 3077-3087.
- Mader, T.L., Dahlquist, J.M. and Gaughan, J.B., 1997. Wind protection effects and airflow patterns in outside feedlots. *Journal of Animal Science* 75: 26-36.
- Mader, T.L., Davis, M.S. and Brown-Brandl, T.M., 2006. Environmental factors influencing heat stress in feedlot cattle. *Journal of Animal Science* 84: 712-719.
- Mader, T.L., Davis, M.S. and Gaughan, J.B., 2007. Effect of sprinkling on feedlot microclimate and cattle behavior. *International Journal of Biometeorology* 51(6): 541-551.
- Mader, T.L., Davis, M.S. and Kreikemeier, W.M., 2005. Case study: tympanic temperature and behavior associated with moving feedlot cattle. *Professional Animal Science* 21: 339-344.
- Mader, T.L., Holt, S.M., Hahn, G.L., Davis, M.S. and Spiers, D.E., 2002. Feeding strategies for managing heat load in feedlot cattle. *Journal of Animal Science* 80(9): 2373-2382.
- McDonald, T.P., Jones, D.D., Barrett, J.R., Albright, J.L., Miles, G.E., Nienaber, J.A. and Hahn, G.L., 1988. Measuring the heat increment of activity in growing-finishing swine. *Transactions of the ASAE* 4: 1180-1186.
- McDowell, R.E., Lee, D.H.K. and Fohrman, M.H., 1953. The relationship of surface area to heat tolerance in Jerseys and Sindhi-Jersey (F1) crossbred cows. *Journal of Animal Science* 12(4): 747-756.
- Mitloehner, F.M., Morrow, J.L., Dailey, J.W., Wilson, S.C., Galyean, M.L., Miller, M.F. and McGlone, J.J., 2001. Shade and water misting effects on behavior, physiology, performance and carcass traits of heat-stressed feedlot cattle. *Journal of Animal Science* 79(9): 2327-2335.
- MLA., 2006a. Feedlot shade structures. Feedlot: FL12. Meat and Livestock Australia, North Sydney, Australia.
- MLA., 2006b. Heat load in feedlot cattle 2002. Feedlot: FL08 – FL13. Meat and Livestock Australia, North Sydney, Australia
- MLA., 2006c. Summer feeding of feedlot cattle. Feedlot: FL11. Meat and Livestock Australia, North Sydney, Australia
- Nienaber, J.A., Hahn, G.L., Brown-Brandl, T.M. and Eigenberg, R.A., 2007. Summer heat waves – extreme years. ASABE Meeting Paper No. 074084. American Society of Agricultural Engineers, St. Joseph, MI, USA.
- Parish, J.A. and Rhinehart, J.D., 2008. Beef cattle water requirements and source management. ASABE Meeting Paper No. P2490. American Society of Agricultural Engineers, St. Joseph, MI, USA.
- Parker, D.B. and Brown, M.S., 2003. Water consumption for livestock and poultry production. In: Stewart, B.S. and Howell, T.A. (eds.) *Encyclopedia of water science*. Marcel Dekker, Inc., New York, NY, USA, pp. 588-592.
- Parker, D.B., Perino, L.J., Auvermann, B.W. and Sweeten, J.M., 2000. Water use and conservation at Texas High Plains beef cattle feedyards. *Applied Engineering in Agriculture* 16(1): 77-82.

- Prayaga, K.C. and Henshall, J.M., 2005. Adaptability in tropical beef cattle: Genetic parameters of growth, adaptive and temperament traits in a crossbred population. *Australian Journal of Experimental Research* 45(7-8): 971-983.
- Robinson, J.B., Ames, D.R. and Milliken, G.A., 1986. Heat production of cattle acclimated to cold, thermoneutrality and heat when exposed to thermoneutrality and heat stress. *Journal of Animal Science* 62(5): 1434-1440.
- Savage, D.B., Nolan, J.V., Godwin, I.R., Mayer, D.G., Aoetpah, A., Nguyen, T., Baillie, N.D., Rheinberger, T.E. and Lawlor, C., 2008. Water and feed intake responses of sheep to drinking water temperature in hot conditions. *Australian Journal of Experimental Agriculture* 48: 1044-1047.
- Schütz, K.E., Rogers, A.R., Poulouin, Y.A., Cox, N.R. and Tucker, C.B., 2009a. The amount of shade influences the behavior and physiology of dairy cattle. *Journal of Dairy Science* 93: 125-133.
- Schütz, K.E., Rogers, A.R., Cox, N.R. and Tucker, C.B., 2009b. Dairy cows prefer shade that offers greater protection against solar radiation in summer: shade use, behavior and body temperature. *Applied Animal Behavior Science* 116(1): 28-34.
- Scott, I.M., Johnson, H.D. and Hahn, G.L., 1983. Effect of programmed diurnal temperature cycles on plasma tyroxine level, body temperature and feed intake of holstein dairy cows. *International Journal of Biometeorology* 27(1): 47-62.
- Sepaskhah, A.R. and Boersma, L., 1979. Thermal conductivity of soils as a function of temperature and water content. *Soil Science Society of America Journal* 43: 439-444.
- Shido, O., 2002. Time memory for heat exposure limited to a fixed daily time in heat-acclimated rats and humans. *Journal of Thermal Biology* 27: 317-324.
- Skinner, J.D. and Louw G.N., 1966. Heat stress and spermatogenesis in *Bos indicus* and *Bos taurus* cattle. *Journal of Applied Physiology* 21(6): 1784-1790.
- Snowder, G.D., Van Vleck, L.D., Cundiff, L.V. and Bennett, G.L., 2006. Bovine respiratory disease in feedlot cattle: Environmental, genetic and economic factors. *Journal of Animal Science* 84(8): 1999-2008.
- St-Pierre, N.R., Cobanov, B. and Schnitkey, G., 2003. Economic losses from heat stress by US livestock industries. *Journal of Dairy Science* 86(13\_suppl): E52-E77.
- Stewart, R.E., 1953. Absorption of solar radiation by the hair of cattle. *Agricultural Engineering* 34: 235-238.
- Stewart, R.E. and Brody, S., 1954. Effect of radiation intensity on hair and skin temperatures and on respiration rates of Holstein, Jersey and Brahman cattle at air temperatures 45, 70 and 80. F. ASABE Meeting Paper No. 561: Columbia, Missouri: Missouri Agricultural Experiment Station and the United States Department of Agriculture Cooperating. University of Missouri, Agricultural Experiment Station, Columbia, MO, USA.
- Thom, E.C., 1959. The discomfort index. *Weatherwise* 12: 57-59.
- Turco, S.H.N., Da Silva, T.G.F., De Oliveira, G.M., Leitao, M.M.V.B., De Moura, M.S.B., Pinheiro, C. and Da Silva Padilha, C.V., 2008. Estimating black globe temperature based on meteorological data. Proceedings of the eighth livestock environment symposium. Iguassu Falls, Brazil, ASABE, St. Joseph, MI, USA, pp. 843-848.
- Turnpenny, J.R., Clark, J.A., McArthur, A.J. and Wathes, C.M., 2000. Thermal balance of livestock. 1. A parsimonious model. *Agricultural and Forest Meteorology* 101(1): 15-27.
- Winchester, C.F. and Morris, M.J., 1956. Water intake rates of cattle. *Journal of Animal Science* 15(3): 722-740.

# 11. The impact of ventilation and thermal environment on animal health, welfare and performance

S.J. Hoff

*Iowa State University, Department of Agricultural and Biosystems Engineering, 212 Davidson Hall, Ames, IA 50011, USA; [hoffer@iastate.edu](mailto:hoffer@iastate.edu)*

## Abstract

From an engineering perspective, animal well-being is intimately related to the thermal energy exchange occurring between the animal and its surroundings. Therefore, it is important to understand the relationship between key variables that drive the exchange of energy, and barn design characteristics that can be implemented to take advantage of these subtle features. Details related to the use of well-defined shapes to model animal heat exchange are discussed and comparisons are made with published animal heat exchange data. These models, after verification of applicability, are then used to investigate subtle features of barn design to improve animal well-being especially as related to heat stress control.

**Keywords** sensible heat, latent heat, heat transfer, heat stress, thermal shield, cooling, animal well-being

## 11.1 Introduction

Understanding animal heat exchange with its environment is a critical step in determining building design features and environmental control strategies for optimum well-being. Animal performance is embedded within their surrounding physical and thermal environment. This article summarizes animal housing features and environmental control strategies influencing the thermal comfort and well-being of housed animals. Sensible and latent heat transfer is considered and factors that influence both, which in turn influences animal comfort and well-being, will be discussed at length with calculated predictions used to investigate alternatives to our current housing practices. From an engineering perspective, animal well-being is intimately related to the thermal energy exchange occurring between the animal and its surroundings. Therefore, it is important to understand the relationship between key variables that drive the exchange of energy and barn design characteristics that can be implemented to take advantage of these subtle features.

The domestication of animals for food production has been quite remarkable. In the not-too-distant past, farm animals were allowed to freely graze on small farms providing food for a handful of recipients, mainly those on-site. Today, an ever-increasing population has demanded a dramatic change in how we raise animals for food. Farm numbers have significantly decreased with a corresponding increase in per farm size to conquer the challenges of an increasing population demand on a limited land base. This article describes the author's perspective on the thermal environment's effects on the housed animal and the housing features that have been developed to help maintain optimum animal health and welfare. Before jumping into modern farm animal

management, a little historical perspective is in order. This history has been paraphrased from the work of Koenig (1994) and a much more detailed description can be found therein.

## **11.2 Brief history of animal housing ventilation**

Ventilation systems for providing fresh-air to either humans or animals can be traced back three hundred years. Hales (1743) commented on a ventilation system described by Henshaw (1677). Henshaw (1677) proposed a twelve foot square airtight 'Air-Chamber' with a pair of large organ bellows placed at one end of the room. Air would be conveyed through copper pipes to or from the room, controlled by valves that open inward or outward. Mechanical ventilation systems were first developed on war ships where plague caused the illness and death of many soldiers, due mainly to the lack of fresh air. Hales (1743) commented that vinegar soaked clothes were hung between ship decks to make the air fresher. Clark-Kennedy (1929) commented on three unrelated experiments aboard ships where devices were designed to draw fresh-air between ship decks through the use of negative pressure ventilation. Triewald (1741) developed a hand-operated bellows device that pulled air between ship decks with port holes used for fresh-air intakes and was granted a patent for this device; it is believed to be the first patent granted for a mechanical ventilation system. Sutton (1744) patented a gravity-based ventilation system where a fire under one chimney provided negative pressure that allowed fresh-air to be drawn through a second chimney.

There were two basic systems of ventilation used in North America during the early 1900's; the King and Rutherford systems. The two methods used were named after the men who invented each. Both systems used gravity (or natural) ventilation. The arrangements of these systems had similar features common to today's natural ventilation systems. Both systems used a chimney out-take flue which relied on the wind to create a vacuum to pull air from the stable. The difference in the two systems was the location of the intake flues. The style of barn also played an important part in the type of ventilation used. Both systems were used in gambrel roof structures. This made gambrel barns an ideal structure to install these systems. Smith (1914), James Manufacturing Company (1916) and Wood (1925) described these methods.

### **11.2.1 The King method**

This method of ventilation was designed by King (1889) and was popular in the United States. In this system, fresh air enters above a sill, rises between studding, enters the barn at the ceiling and then is distributed by registers to circulate in the room as shown in Figure 11.1. The deflector for the register is adjusted by a stick moved to various notches in the wall. The area for fresh air inlet was equal to the area of air outlets. Also, the size of the inlet flue was limited to the stud spacing. One problem with this system was during very cold weather. Cold air flowing in between wall studs cooled the wall allowing warm moist air on the inside to condense on the wall, producing a thick layer of frost. In the King system, Ocock (1908) suggested that the 'inlet or fresh air flues should be placed not more than 10' apart and located in the exterior walls of the barn.' Also, 'the greater the number (of intake flues), the more effective the ventilation since they enable the fresh air to displace the foul air more rapidly.'

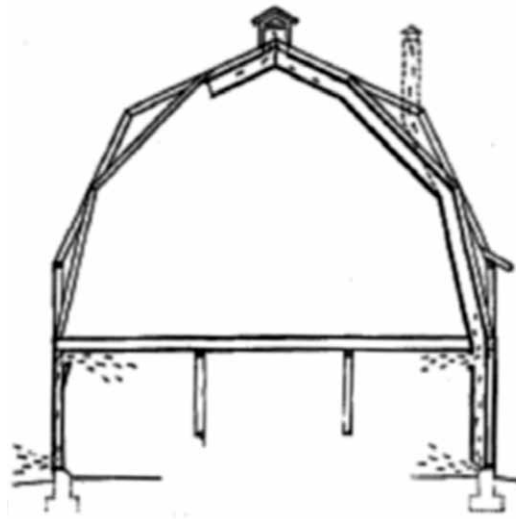

Figure 11.1. King ventilation system (Smith, 1914).

### 11.2.2 The Rutherford method

This method of ventilation was popular in Canada. In this system, fresh air entered at the base of the barn wall as shown in Figure 11.2. The theory behind this system was that as air warms, it will naturally rise. With air inlets located properly, there will be a better distribution of air and the airflow will pick up and exhaust the foul air created by the manure quicker. In the Rutherford method, the total area of the outlet flue is twice the total of the area of the inlet flues.

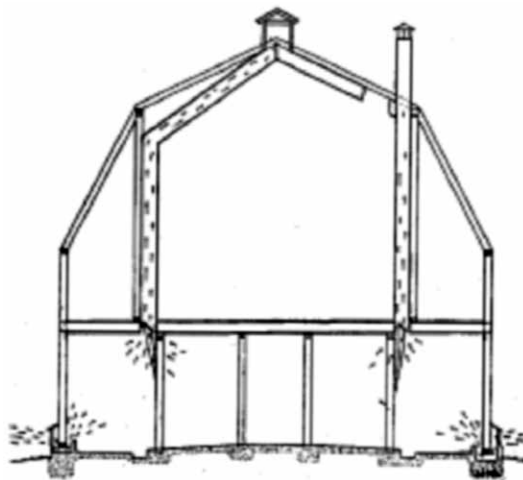

Figure 11.2. Rutherford ventilation system (Smith, 1914).

Armsby and Kriss (1921a) wrote that heat production of animals was important in producing the motive power of natural ventilation. They concluded that when the wind was not blowing, the sole motive power in the operation of natural ventilation was from heat and water vapour production by animals. Armsby and Kriss (1921a) stated that as water vapour content increased, the motive power increased. This is because water vapour will make the air lighter. When the wind was not blowing, the ideal condition for increasing ventilation was to increase the temperature difference and saturate the inside air. Armsby and Kriss (1921b) stressed that the type of ration animals were fed was important to animal growth and the amount of heat given off by the animals. They suggested that rations should be changed in the winter to increase heat production of animals thus increasing the temperature and ventilation rate in the barn. The limitations of natural ventilation were apparent to farmers. Stapleton (1940) noted that natural ventilation systems were good low cost investments for ventilating buildings, but problems arise during strong storm winds and sudden drops in temperature. Using ventilating fans can overcome these problems. As reported in Stapleton (1940), ventilating with fans has a higher initial cost which could be recovered by saving one cow from tuberculosis or pneumonia or an increase of 5 lbs of milk per cow during the winter months.

### **11.3 Modern animal housing**

Animal housing has evolved tremendously from the rather primitive, yet innovative, systems developed by the early pioneers. Economic and land pressures, combined with an ever-increasing population, has forced the animal industry into the production systems we have today. It is not uncommon today to have 4,000 fattening pigs in four 1000 head buildings in a land area of no more than 4 hectares, being tended to by one stockman, spending no more than three hours a day with animals being kept in environments at times better than we can control in our own homes. A truly remarkable feat when one stops to consider the days when individual households raised just enough food to provide for an immediate family. The following highlights specific animal housing designs, the logic behind these designs, the climate control methods used to reduce animal stress and improve well-being, and a look at the future from this author's perspective.

### **11.4 Animal housing characteristics**

The early pioneers in animal housing and ventilation design had the luxury of developing systems that carried their names like 'The King' or 'The Rutherford' methods of barn ventilation. Today, no such acclaim can be given to any one design for rearing farm animals. Barn styles and methods of climate control have become regionalized, maximizing animal performance in the specific climatic region of the world. A few Upper Midwestern region examples of modern livestock housing are given below.

#### **11.4.1 Natural ventilation**

The early pioneers referred to natural ventilation as gravity ventilation. In essence, gravitational forces are used to supply the required fresh-air exchange rates in this type of ventilation strategy. As the early pioneers quickly realized, heated and water vapour-laden air is lighter than colder drier air and these forces, represented as a difference in moist air density, can be exploited to



## 11. The impact of ventilation and thermal environment

force fresh-air through animal housing facilities. Barn designs today for exploiting the natural ventilation process, as you can imagine, are more sophisticated than our early pioneer designs, but the physics of the process has always been the same.

Broilers, turkeys, fattening pigs, beef and dairy animals have traditionally used natural ventilation housing designs. Typical of these structures would be controlled openings at the building sides combined with an opening at the ridge. Figure 11.3 is a naturally ventilated pig fattening facility used today.

### 11.4.2 Mechanical (forced) ventilation

The need for tighter climate control for young immature animals has forced animal housing, over time, to more fan ventilated facilities. With multiple fans, staged according to animal needs and outside climatic forces, a much tighter climate control can be achieved. Farrowing sows, young immature pigs, pullets and laying hens have all greatly benefitted from tighter climate control afforded by fan ventilated barns. Figure 11.4 is a typical mechanically ventilated farrowing facility utilizing sidewall fans used throughout the US.

### 11.4.3 Hybrid ventilation

In many situations, climatic forces allow the benefits of natural ventilation, with the tighter control afforded by fan ventilation. These so-called hybrid ventilation systems have evolved accordingly. Figure 11.5 is an example of a hybrid-ventilated sow gestation facility. In cold winter conditions, sidewall curtains are closed allowing sidewall fans to pull fresh-air in the attic and dispersed in the animal occupied zone through ceiling diffusers. As climatic conditions warm, typical of spring or fall, sidewall curtains drop proportionally and allow natural cross-ventilation of the barn. In



Figure 11.3. Naturally ventilated pig building with chimneys and sidewall curtains with split-zone control of one room.





Figure 11.4. Modern-day mechanical ventilation system with sidewall fans for ventilation control.



Figure 11.5. (a) Hybrid ventilation system with fans for cold-to-mild ventilation and curtains for warm-to-hot weather ventilation. (b) Hybrid ventilation system with tunnel fans for hot weather airspeed control.

the warmest climatic conditions, large propeller fans pull outside air directly through evaporative cooling pads and draw this cooled air through the barn in a tunnel fashion.

### 11.5 Climate control and environmental stressor mitigation

From an engineering perspective, minimizing any negative consequences of the thermal environment on housed animals is a lesson in heat transfer and the thermal exchanges that take place between the animal and its climatic surroundings. Thermal exchange between an animal and its surroundings can be categorized into two main modes of energy exchange; sensible and latent.

Sensible heat exchange is thermal energy exchanged as a result of a temperature difference. For example, the core temperature of a pig is near 39.5 °C, and any surface or fluid in the surroundings different from 39.5 °C will cause an exchange of thermal energy through sensible means. These sensible heat exchanges come in the form of conduction, convection, and thermal radiation. Conduction energy exchange is that portion of thermal exchange occurring as a result of direct contact with a surface different from the core temperature of the animal. Convection energy exchange is that portion of thermal exchange occurring as a result of contact with a fluid such as air or water, either moving or still, and at a different temperature than the surface of the animal. Thermal radiation energy exchange is that portion of sensible heat transferred as a result of surrounding surface temperatures that differ from the surface of the animal *and that are not in contact with the animal*. For example, radiant heat lamps are common housing features for immature animals, where a high-temperature lamp is allowing thermal radiation energy to impinge upon the animal's surface, where it can be absorbed or reflected. Thermal radiation heat exchange is often ignored when considering animal thermal comfort, but in reality can, in many cases, represent 50% of the sensible energy exchange with its surroundings, thereby contributing a great deal to animal comfort or distress.

Latent heat exchange is that portion of thermal interaction that results in a liquid-to-vapour phase change. For animals, the energy released when liquid water evaporates can be quite large and in many cases represents the only mechanism to combat the negative consequences of heat stress. For example, if all surfaces surrounding an animal, both in contact and otherwise, and the fluid (i.e. air) surrounding an animal were all equal to the core temperature of the animal, it is latent heat exchange alone that can be used to release excess thermal energy from the animal to stave off the negative consequences of heat stress. In some cases, the animal in question has poor or non-existent sweat glands, such as the pig, and artificial methods of direct skin wetting have been used to allow artificial sweating to occur and hence promote the thermal release benefits of latent heat exchange.

### 11.6 Specific heat transfer mechanisms

The following will in general define the processes involved in the sensible and latent heat exchanges described above. The purpose of this discussion is to understand the specific climatic control housing features that can be manipulated to subsequently change the thermal interactions between the animal and its surroundings. It is certainly not intended to be a detailed description of the physics of heat transfer.

### 11.6.1 Conduction heat transfer

Conduction heat transfer involves the transfer of thermal energy from one object to another in contact. The key criteria for conduction heat transfer is that flow of energy is by contact between two surfaces at different temperatures and thus the surface area in contact between objects is critical. Conduction heat transfer can be described by:

$$Q_{cd} = A \times \frac{T_H - T_C}{R} \quad (11.1)$$

where:

- $Q_{cd}$  = total conduction energy (W)
- $A$  = contact surface area normal to direction of heat flow  $Q_{cd}$  ( $m^2$ )
- $(T_H - T_C)$  = temperature difference between hot and cold surfaces in contact ( $^{\circ}C$ )
- $R$  = resistance to conduction heat flow  $=L/k$  ( $m^2 - ^{\circ}C/W$ )
- $L$  = path length that heat travels in the direction of heat flow (m)
- $k$  = thermal conductivity of the of the media heat travels through ( $W/m - ^{\circ}C$ )

Equation 11.1 is the simplest form of heat conduction that can occur, and insights into this simple equation can be used to dictate animal housing climate control. The resistance to conduction heat transfer ( $R$ ) in Equation 11.1 makes intuitive sense. As the path length ( $L$ ) for heat to flow increases, the resistance to heat flow increases. As the thermal conductivity ( $k$ ) decreases the resistance to heat flow increases. Good insulators to conduction heat transfer can be achieved with large path lengths or low thermal conductivities, or combinations of the two.

Sows in farrowing during hot weather conditions, struggle continuously to maintain thermo-neutrality. One potential method of cooling, not common yet in sow housing, is to present the sow a surface maintained at a temperature substantially lower than her deep-body core temperature. For example, if a cooling mat of  $1 m^2$  was placed beneath a sow, with a sow tissue resistance  $R=L/k=0.052 (m^2 - ^{\circ}C/W)$  (Blaxter, 1989), and she laid completely on this cooled surface, maintaining this cooling mat at  $18 ^{\circ}C$  with circulated well water for example would allow for a release of sensible heat via conduction of:

$$Q_{cd} = 1.0 (m^2) \times \frac{(39.5 - 18) (^{\circ}C)}{0.052 (m^2 - ^{\circ}C/W)} \quad (11.2)$$

$$Q_{cd} = 414 (W)$$

To put this number into perspective, a 180 kg sow in a heat stress situation will physically be able to release about 234 W (1.3 W/kg) of total energy, mostly through higher respiration rates (Fuller, 2004; ASABE, 2006). Providing a simple cooling mat as described would substantially increase the sow's ability to remove excess heat and maintain thermo-neutrality.

### 11.6.2 Convection heat transfer

Convection heat transfer involves the transfer of thermal energy from one object to another by the action of a fluid, either moving or still. The key criteria for convection heat transfer is that flow

## 11. The impact of ventilation and thermal environment

of energy is from one object, the animal's surface, to a fluid (or *vice versa*) by virtue of a difference in temperature between the fluid (i.e. generally air) and the animal's surface. Convection heat transfer from an animal's surface can be described by:

$$Q_{cv} = h \times A \times (T_{sk} - T_{\infty}) \quad (11.3)$$

where:

- $Q_{cv}$  = sensible heat transferred by convection (W)
- $h$  = convective heat transfer coefficient ( $W/m^2 - ^\circ C$ )
- $A$  = surface area exposed to temperatures  $T_{sk}$  and  $T_{\infty}$  ( $^\circ C$ )
- $T_{sk}$  = animal skin surface temperature ( $^\circ C$ )
- $T_{\infty}$  = fluid temperature surrounding skin ( $^\circ C$ )

Although seemingly very simple, convection heat transfer becomes complicated when trying to determine an appropriate convection heat transfer coefficient for a given problem. If the fluid under consideration is moving due to some external motive force, then the process is called 'forced' convection. If the fluid is moving due to variations in fluid density only, the process is called 'natural' or 'free' convection.

As the relative fluid velocity increases over a surface, the convective heat transfer coefficient will increase, but at decreasing rates, eventually reaching a maximum. Doubling the airspeed for example will not double  $h$ , and eventually doubling the airspeed results in almost no further increase in  $h$ . For example, take the case of a sphere exposed to a moving airstream. The convection heat transfer coefficient has been experimentally determined to be (Holman, 2002)

$$h = 0.37 \times (k_f / D) \times (U_{\infty} \times D \times \rho_f / \mu_f)^{0.6} \quad (11.4)$$

where:

- $k_f$  = thermal conductivity of air (kg/m-s)

For example, assuming air at  $20^\circ C$ , the fluid properties of interest become  $k_f=0.0257 W/m - ^\circ C$ ,  $\rho_f=1.21 kg/m^3$ , and  $\mu_f=1.83 \times 10^{-5} kg/m-s$ . If the air is moving past a 0.20 m diameter sphere at a velocity of 10 m/s, the convective heat transfer coefficient becomes:

$$h = 0.37 \times \frac{0.0257}{0.20} \times \left( \frac{10 \times 0.20 \times 1.21}{1.83 \times 10^{-5}} \right)^{0.6} = 56 (W/m^2 - ^\circ C)$$

If the air velocity past the sphere doubles to 20 m/s,  $h$  increases to  $85 W/m^2 - ^\circ C$ ; a 51% increase for a doubling of the airspeed. The convective heat transfer coefficient is increasing with increasing  $U_{\infty}$  but at a diminishing rate. This phenomenon has had an indirect influence on animal housing ventilation system design as will be shown later.

### 11.6.3 Radiation heat transfer

Radiation heat transfer involves the transfer of thermal energy from one surface to another by virtue of a temperature difference and the amount of surface 'viewing' between objects. The

## S.J. Hoff

maximum possible heat released by thermal radiation for an object at any temperature above absolute zero is defined by the Stefan-Boltzmann Law:

$$Q_{\text{rad}} = A \times \sigma \times T^4 \quad (11.5)$$

where:

- $Q_{\text{rad}}$  = radiation heat released by an object at surface temperature  $T$  (W)
- $\sigma$  = Stefan-Boltzmann constant  $5.67 \times 10^{-8}$  (W/m<sup>2</sup>-K<sup>4</sup>)
- $A$  = surface area (m<sup>2</sup>)
- $T$  = surface temperature (K)

For typical surfaces experienced in practice, the maximum emission described by Equation 11.5 does not occur and a correction factor, based on surface properties, is introduced as:

$$Q_{\text{rad}} = A \times \varepsilon \times \sigma \times T^4 \quad (11.6)$$

where:

- $\varepsilon$  = emissivity of a surface, varies from 0-1 (dimensionless)

Thermal radiation is by far the most cumbersome heat transfer mechanism to handle because of several complicating features. First, radiation heat transfer is a function of the 4<sup>th</sup> power of temperature thus adding a degree of complexity not found in conduction or convection heat transfer. Second, the exchange of thermal radiation between surfaces is complicated by the fact that thermal radiation energy can be reflected by surfaces, ending up at other surfaces. This alone adds a great deal of complexity. Third, the degree that surfaces exchange thermal radiation energy depends on the geometry between surfaces. If one surface does not 'radiatively see' or 'view' another, no direct exchange of thermal radiation energy will result. Finally, thermal radiation energy exchange is a function of the surface characteristics which in turn affects the emission, reflection and absorption fractions of thermal radiation. A bright shiny aluminium sheet for example has properties that vary greatly once this sheet becomes dirty or oxidized. These factors make thermal radiation complicated and beyond the scope of this discussion.

There is one special case of thermal radiation heat transfer that can be used to assess climatic factors on animal heat exchange. This case, referred to as a 'small object in a large room' (Holman, 2002) is described as:

$$Q_{\text{rad}} = A_b \times \varepsilon_b \times \sigma \times (T_{\text{sk}}^4 - T_r^4) \quad (11.7)$$

where:

- $A_b$  = surface area (m<sup>2</sup>)
- $\varepsilon_b$  = skin surface emissivity (=0.90 for most animal surfaces at long-wave radiation)
- $T_{\text{sk}}$  = skin surface temperature of housed animal (K)
- $T_r$  = surface temperature of surrounding surfaces not touching an animal (K)

## 11. The impact of ventilation and thermal environment

Equation 11.7 assumes that all surrounding surfaces exposed to the animal are at some constant temperature. For example, assume we have a 2 kg broiler chicken. The surface area of this chicken can be estimated as  $A_b = 0.01064 \times 2^{0.677} = 0.02 \text{ m}^2$  (Mitchell, 1930). If the bird's surface temperature was at 35 °C with the surrounding surfaces at 19 °C, the radiation heat loss to the surrounding surfaces would be:

$$Q_{\text{rad}} = 0.02 \times 0.90 \times 5.67 \times 10^{-8} \times (308^4 - 292^4) = 1.8 \text{ (W)}$$

To put this number into perspective, a 2 kg broiler chicken releases about 10 W of total sensible heat at an ambient temperature of 19 °C (ASABE, 2006). This simplified thermal radiation calculation represents about 20% of the total sensible heat transferred of the bird, at this temperature.

### 11.6.4 Latent heat transfer

Latent heat transfer, as mentioned previously, involves the transfer of heat energy through phase changes. Ice-to-liquid water and liquid water-to-water vapour are the phase changes most familiar to us. Animal comfort and well-being can be dramatically affected by latent heat transfer mechanisms and a basic understanding is paramount. Homoeothermic systems respire at a level consistent with their thermal environment. Higher respiration rates are indicators of heat stress control measures being taken by the animal. For example, sows in a non-heat stressed condition typically respire at about 20-40 breaths/min (bpm; Eigenberg *et al.*, 2002). A heat stressed sow will quickly respire in excess of 80 bpm. Significant latent heat release from an animal can be realized through respiratory tract evaporation of water. This energy, called the Latent Heat of Vaporization ( $h_{fg}$ ), is usually the last line of defence as homoeothermic systems stave off the effects of heat stress. For liquid water, the Latent Heat of Vaporization ( $h_{fg}$ ) is a function of the water's temperature ( $T$ ) and is:

$$h_{fg} = 2,501 - 2.42 \times T \quad (11.8)$$

where  $h_{fg}$  has units kJ/kg<sub>w</sub> evaporated and  $T$  is in °C. For example, if a dairy cow inhales unsaturated room air, a certain fraction of liquid water in her respiratory tract will be evaporated. This evaporated liquid water, now a vapour, removes the Latent Heat of Vaporization worth of energy, originating from the cow's 'power plant'. Each kg of water evaporated from a cow's respiratory tract (at an assumed 37 °C) will remove roughly:

$$h_{fg} = 2,501 - 2.42 \times 37 = 2,411 \text{ kJ/ kg}_w$$

If this 1 kg<sub>w</sub> was evaporated in one hour, the cow would release roughly 670 W from her body. To put this into perspective, the published latent heat data for a 500 kg dairy cow indicates a latent heat transfer of about 650 W at a surrounding air temperature of 27 °C (ASABE, 2006). Many studies have been conducted to estimate the latent heat released by animals. For pigs, with poorly performing sweat glands, the latent heat transferred is via respiration. For example, for 100 kg pigs, the moisture production ( $m_{\text{dot},w}$ ; kg<sub>w</sub>/s) as a function of surrounding air temperature ( $T_\infty$ ) can be summarized from data published in ASABE (2006), valid for temperatures between 5 and 30 °C, as:

## S.J. Hoff

$$m_{\text{dot,w}} = 4.2 \times 10^{-8} \times T_{\infty}^2 - 5.7 \times 10^{-7} \times T_{\infty} + 2.9 \times 10^{-5}$$

To convert to actual latent heat released ( $Q_{\text{resp}}$ , Watts), ( $h_{\text{fg}}$ ) at an estimated respiratory tract temperature of about 37 °C results in:

$$\begin{aligned} Q_{\text{resp}} &= m_{\text{dot,w}} \times h_{\text{fg},37 \text{ } ^\circ\text{C}} \\ &= 1000 \times (4.2 \times 10^{-8} \times T_{\infty}^2 - 5.7 \times 10^{-7} \times T_{\infty} + 2.9 \times 10^{-5}) \times (2,501 - 2.42 \times 37) \end{aligned} \quad (11.9)$$

### 11.7 The animal and its thermal environment

The brief discussion presented above on sensible and latent heat is a fundamental first step in understanding how climatic surroundings either positively or negatively affect the housed animal. For sensible heat, two common parameters are present with conduction, convection and radiation; namely exposed surface area and a representative temperature difference. Therefore, manipulating or at least understanding these two parameters will help understand why certain animal housing styles have evolved as they have.

We all see that infants and immature animals require warm draft-free environments. From an engineering perspective, this phenomenon can be explained with the relationship between an animal's surface area relative to its body mass. Take the case of pigs. Brody *et al.* (1928) experimentally determined that the surface area of a pig could be estimated as:

$$A = 0.097 \times W^{0.633} \quad (11.10)$$

where:

$$\begin{aligned} A &= \text{surface area (m}^2\text{)} \\ W &= \text{pig body mass (kg)} \end{aligned}$$

If one plots (Figure 11.6) the surface area-to-body mass ratio (A:W) as a function of body mass, insights into why immature animals require special attention for their thermal comfort and well-being can be realized. Young immature pigs (say 5 kg) have a very large surface area to mass ratio compared to their mature mass (say 100 kg), and in fact is 3 times higher. Thermal comfort is in turn influenced by the exchange of thermal energy, and since three of the four mechanisms for gaining/losing thermal energy are direct functions of surface area, a large surface area to 'power plant' size will be more influenced by the surrounding climatic conditions. Animal housing methods go to great lengths to ensure that immature animals are maintained in warm, draft-free environments for this reason. One further observation from Figure 11.6 is that as pig's mature, there is very little further increase in actual total surface area. A 200 kg pig realizes a A:W ratio of about 0.012 m<sup>2</sup>/kg (2.4 m<sup>2</sup> total) vs. a 100 kg pig with a A:W ratio of about 0.019 m<sup>2</sup>/kg (1.9 m<sup>2</sup> total). This reduction in A:W ratio as animals mature is a limitation in combating the influences of heat stress.

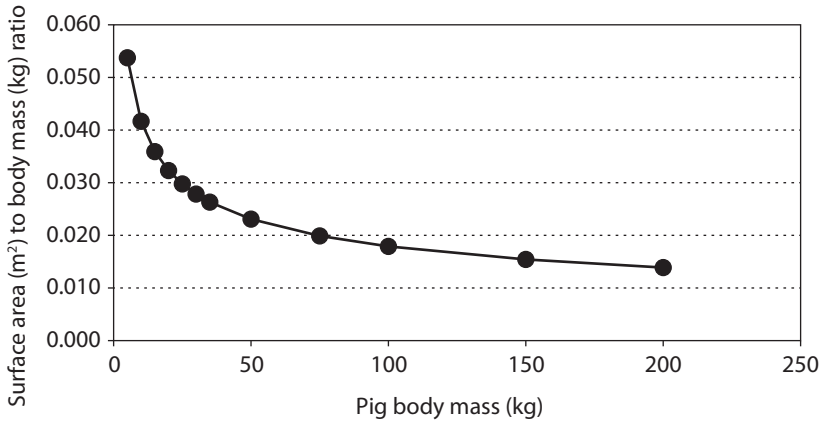

Figure 11.6. Surface to body mass ratio given as a function of body mass for pigs.

### 11.8 Accuracy of estimating heat loss

It is convenient to use well defined shapes (spheres and cylinders) to model and estimate animal heat loss. Great insights into the influence of animal housing on thermal interactions with the animal can be realized, even though this approach may seem like a large leap of faith from reality. Certainly, a physiologically responding homeothermic system will behave far different than these inanimate objects used to model them. Therefore, it is worth the effort to see how accurate these simplifications are before using them in evaluating the thermal environment for the animal.

Take pigs as our example. Most all heat production data for pigs has been conducted for single animals standing in direct or indirect calorimeters. A literature review on pig heat production data, HP (Brown-Brandl *et al.*, 2004) shows that for pigs between 10-100 kg body mass, a summary of 15 independent experimental studies between 1959 and 2002 can be summarized as:

$$HP = 14.95 \times W^{-0.40} \text{ (W/kg)} \quad (11.11)$$

This heat production represents the total of sensible and latent. Take pigs at 30, 65 and 100 kg body mass and model each as horizontal cylinders at lengths of 0.91, 1.1, and 1.2 m respectively (ASABE, 2006). Assume in all cases the airspeed is still at 0.12 m/s (as in indirect calorimeters used to collect production data) and the air and wall temperatures surrounding the pig are equal and at 20 °C (typical as well for calorimeter studies). For a standing pig, only convection and thermal radiation heat transfer are important in sensible heat exchange. These two can be predicted as before using Equations 11.3 and 11.7:

$$Q_{cv} = h \times A_b \times (T_{sk} - T_a) \quad (11.12)$$

$$Q_{rad} = A_b \times \epsilon_b \times \sigma \times (T_{sk}^4 - T_r^4)$$



## S.J. Hoff

where:

- $h$  = convective heat transfer coefficient for a horizontal cylinder (Holman, 2002)  
 $= (2.78/D^{0.534}) \times U_{\infty}^{0.466}$
- $D$  = equivalent cylinder diameter, ends ignored =  $A_b/(\pi L)$
- $U_{\infty}$  = airspeed over animal surface (m/s)
- $A_b$  = surface area for pigs =  $0.097 \times W^{0.633}$  (m<sup>2</sup>)
- $W$  = body mass (kg)
- $L$  = cylinder length used to model animal (m<sup>2</sup>)
- $T_{sk}$  = approximate animal skin surface temperature = 37 (°C)
- $T_a$  = surrounding air temperature = 20 (°C)
- $\epsilon$  = surface emissivity = 0.90 (dimensionless)
- $\sigma$  = Stefan-Boltzmann constant =  $5.67 \times 10^{-8}$  (W/m<sup>2</sup>-K<sup>4</sup>)
- $T_r$  = representative surrounding surface temperature = 293 (K)

The latent heat loss can be modelled in the form of Equation 11.9 as:

$$Q_{resp} = (A \times T_{\infty}^2 - B \times T_{\infty} + C) \times 2,411 \times 1000 \text{ (W)}$$

with the coefficients A, B, and C estimated using moisture production data from ASABE (2006).

For 30 kg pigs (L=0.91 m, D=0.29 m):

$$Q_{cv} = (2.78/0.29^{0.534}) \times 0.12^{0.466} \times (0.097 \times 30^{0.633}) \times (37 - 20) = 15 \text{ (W)}$$

$$Q_{rad} = (0.097 \times 30^{0.633}) \times (0.90) \times (5.67 \times 10^{-8}) \times (310^4 - 293^4) = 79 \text{ (W)}$$

$$Q_{resp} = (3.7 \times 10^{-8} \times 20^2 - 4.9 \times 10^{-7} \times 20 + 1.58 \times 10^{-5}) \times 2,411 \times 1000 = 50 \text{ W}$$

$$Q_{total} = (15 + 79 + 50) = 144 \text{ (W)} \\ = 4.8 \text{ (W/kg) predicted, HP} = 14.95 \times (30)^{-0.40} = 3.8 \text{ (W/kg) experimental}$$

For 65 kg pigs (L=110 cm, D=41 cm):

$$Q_{cv} = hA(T_{sk} - T_a) = (2.78/0.41^{0.534}) \times 0.12^{0.466} \times (0.097 \times 65^{0.633}) \times (37 - 20) = 23 \text{ W}$$

$$Q_{rad} = A_b \epsilon_b \sigma (T_{sk}^4 - T_r^4) = \{(0.097)65^{0.633}\}(0.90)(5.67 \times 10^{-8})(310^4 - 293^4) = 130 \text{ W}$$

$$Q_{resp} = (4.5 \times 10^{-8} \times 20^2 - 6.4 \times 10^{-7} \times 20 + 2.3 \times 10^{-5}) \times 2,411 \times 1000 = 67 \text{ W}$$

$$Q_{total} = (23 + 130 + 67) = 212 \text{ W} \\ = 3.4 \text{ W/kg predicted, } 14.95(65)^{-0.40} = 2.8 \text{ W/kg experimental}$$

For 100 kg pigs (L=120 cm, D=47 cm):

$$Q_{cv} = hA(T_{sk} - T_a) = (2.78/0.47^{0.534}) \times 0.12^{0.466} \times (0.097 \times 100^{0.633}) \times (37 - 20) = 28 \text{ W}$$

## 11. The impact of ventilation and thermal environment

$$Q_{\text{rad}} = A_b \epsilon_b \sigma (T_{\text{sk}}^4 - T_r^4) = (0.097 \times 100^{0.633}) \times 0.90 \times 5.67 \times 10^{-8} \times (310^4 - 293^4) = 170 \text{ W}$$

$$Q_{\text{resp}} = \{4.2 \times 10^{-8} \times 20^2 - 5.7 \times 10^{-7} (T_a) + 2.9 \times 10^{-5}\} \times 2,411 \times 1000 = 82 \text{ W}$$

$$Q_{\text{total}} = (28 + 170 + 82) = 280 \text{ W} \\ = 2.8 \text{ W/kg predicted, } 14.95 \times 100^{-0.40} = 2.4 \text{ W/kg experimental}$$

In all three cases, the predicted total heat production using horizontal cylinders to model pigs was higher than the summarized measured data by 26, 21 and 17% respectively. Nevertheless, using these theoretical relations of heat transfer to assess heat production and the influence of several environmental variables on heat production appears to be quite acceptable and therefore some confidence exists in using these relations to make an assessment of the animal's environment and housing features to improve the environment; the topic of the following section. Please note as well that under the conditions presented above, with low airspeeds typical of calorimeter studies, the convective heat transfer was in each case far less than the predicted thermal radiation loss adding further support to the importance of thermal radiation heat transfer on animal thermal comfort.

### 11.8.1 Convective heat transfer influence on modern barn design

If the air temperature is cooler than an animal's core, fast moving air over our bodies has a cooling effect as a result of convective heat exchange. This convective cooling effect is influenced by many factors besides surface area exposure as discussed above. Animal housing designs today have been greatly influenced by the action of convection heat transfer. For example, take a broiler standing in a barn. This broiler, from an engineering point of view, is a heated sphere suspended above the floor, being influenced thermally by the surrounding air temperature, air movement and surrounding surface temperatures. Experimentally, the convective heat transfer coefficient ( $h$ ) for air passing over a sphere was presented earlier. If a 15 cm diameter sphere is used to model the broiler, and air properties at 27 °C (300 K) are used, the convective heat transfer coefficient as a function of airspeed is as shown in Figure 11.7. As airspeed increases,  $h$  will increase as well, and all other factors being equal (all temperatures and exposed surface area), convective heat loss will increase resulting in a cooling effect for the broiler.

The more interesting aspect of Figure 11.7 however is the diminishing  $h$  as airspeed increases, given in Figure 11.7 as the convective benefit  $dh/dU_{\infty}$ . This feature, of diminishing  $h$  with  $U_{\infty}$ , has found its way cleverly into modern animal housing. For example, tunnel ventilated barns were 'invented' primarily in the south-eastern section of the US to create an artificial wind over broilers in regions where natural wind effects were small during hot summer days. However, the question has always been at what airspeed should these barns be designed for? The answer can easily be explained with Figure 11.7. Up to about 2 m/s there is a significant increase in  $h$  relative to further increases in  $U_{\infty}$ . Beyond  $U_{\infty} = 2$  m/s however, little additional increase in  $h$  is realized for further increases in  $U_{\infty}$ . Therefore, it seems reasonable to design broiler tunnel barns at about 2 m/s airspeeds and in fact, most of the original tunnel-ventilated broiler barns at moderate lengths (<100 m) were designed for airspeeds at or near this level. In either case, the thermal interaction

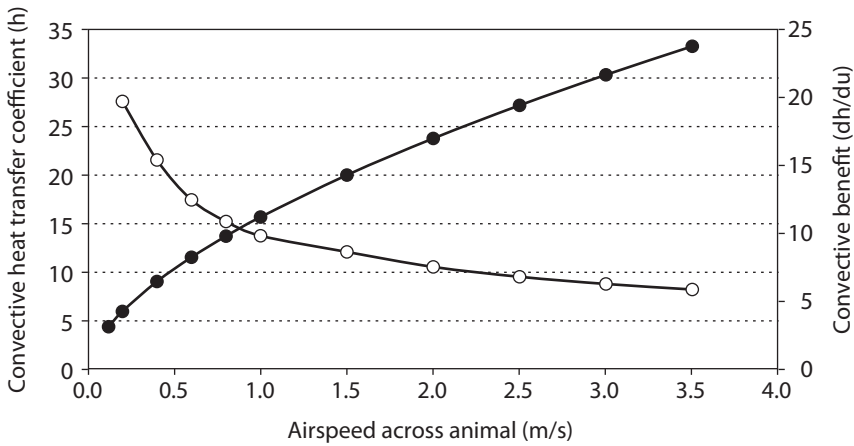

Figure 11.7. Sphere convective heat transfer coefficient and convective benefit as a function of airspeed over the sphere.

between the bird and the climatic surroundings dictated barn design ultimately through the action of convection heat transfer.

Consider the situation shown in Figure 11.8. This plot shows the convective heat transfer coefficient for pigs modelled as horizontal cylinders with the airspeed perpendicular to the long axis of the cylinder ('cylinder in cross-flow'). Two pig sizes are given, one for a 15 cm diameter pig and the other for a 30 cm diameter pig. At any given airspeed, the convective heat transfer coefficient increases and is higher for the smaller pig at any  $U_{\infty}$ . Again however, above about 2 m/s, the influence of increasing  $U_{\infty}$  on  $h$  diminishes ( $dh/dU_{\infty}$ ) and represents reasonable target airspeeds for tunnel designed ventilation systems. Again, most all Midwestern pig fattening and gestation facilities are designed with target airspeeds near 2 m/s and in some way in their past were dictated by convective heat transfer limitations of increasing  $U_{\infty}$  on  $h$ .

Tunnel designs are so prevalent today that a further analysis is in order. The tunnel design airspeed, if used exclusively for barn ventilation rate design, can be detrimental as the tunnel length increases. Simply put, since the purpose of tunnel designed barns is to produce a wind effect on animals, and since the convective heat transfer benefit reduces substantially above about 2 m/s, it makes sense to use this knowledge to determine the maximum tunnel barn length that can be effectively ventilated in harmony with convective heat transfer. As 2 m/s air flows through the barn, heat, moisture, particulates and gases increase through the barn down the length of the barn due to prior occupant inputs to the ventilation air. Most maximum ventilation rates used for design are based in some way on minimizing the maximum temperature increase that a barn experiences due to ventilation air alone. One method, called the '2 °C rule' (Albright, 1990) is intended to limit the maximum temperature increase of the barn to no more than 2 °C above the entering air temperature. Figure 11.9 plots the temperature profile along the length of a tunnel ventilated barn with 100 kg pigs at a density of 0.70 m<sup>2</sup>/pig. The equation describing this result is

## 11. The impact of ventilation and thermal environment

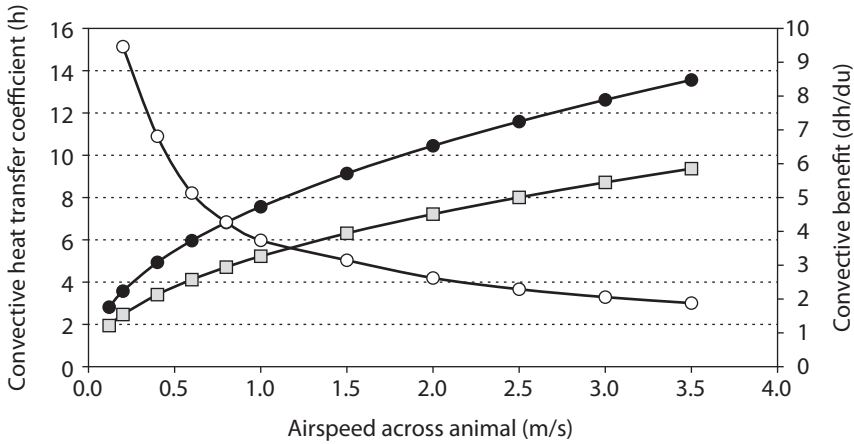

Figure 11.8. Cylinder in cross-flow convective heat transfer coefficient for a 15 cm diameter cylinder, a 30 cm diameter cylinder and the convective benefit as a function of airspeed over the cylinder.

a finite difference approximation to the sensible heat balance (solar loading ignored) as outside air traverses through the barn, solved sequentially through the barn from inlet-to-exhaust as:

$$T_{x+\Delta x} = T_x + \{(Q_{cv} + Q_{rad}) \Omega - Q_{bldg}\} \Delta x / (m_{dot} c_p) \quad (11.13)$$

The thermal radiation heat loss from an animal ( $Q_{rad}$ ) is not energy that directly heats the surrounding air, and therefore it is more appropriate to remove this sensible heat component from this analysis resulting in:

$$T_{x+\Delta x} = T_x + \{(Q_{cv} \Omega - Q_{bldg}) \Delta x / (m_{dot} c_p) \quad (11.14)$$

where:

- $T_{x+\Delta x}$  = barn air temperature at location  $x+\Delta x$  (K)
- $T_x$  = barn air temperature at location  $x$  (K)
- $Q_{cv}$  = per animal convection heat loss =  $A_b h (T_{sk} - T_x)$  (W/animal)
- $Q_{rad}$  = per animal thermal radiation heat loss =  $A_b \epsilon_b \sigma (T_{sk}^4 - T_x^4)$  (W/animal)
- $Q_{bldg}$  =  $\{(W+2H)/R_{eq}\} (T_x - T_\infty)$  (W/m length of building)
- $W$  = barn width perpendicular to tunnel airspeed direction (m)
- $H$  = barn floor-to-ceiling averaged height (accounts for open internal gable) (m)
- $c_p$  = air specific heat at constant pressure, 1,006 (J/kg - °C)
- $m_{dot}$  = mass flow rate through barn =  $U_\infty \times W \times H \times \rho$  (kg/s)
- $\rho$  = air density, 1.17 (kg/m<sup>3</sup>)
- $U_\infty$  = tunnel design airspeed (m/s)
- $\Omega$  =  $W/\alpha$  (animals/m length of barn)
- $\alpha$  = animal density (m<sup>2</sup>/animal)
- $T_\infty$  = temperature of outside air (K)

$R_{eq}$  = equivalent thermal resistance of sidewalls and roof/ceiling combination ( $m^2 - ^\circ C/W$ )  
 $\Delta x$  = solution increment along length barn (m)

For the case shown in Figure 11.9,  $\Delta x=0.10$  (m),  $R_{eq}=2.5$  ( $m^2 - ^\circ C/W$ ),  $\alpha=0.70$  ( $m^2/pig$ ),  $H=2.44$  (m),  $W=15$  (m) with tunnel airspeeds of  $U_\infty=1, 2$  and  $3$  (m/s). If one follows the  $2^\circ C$  rule, a tunnel barn under these conditions with design airspeeds of 1, 2 or 3 m/s should be no longer than about  $L=50, 75$  and  $95$  m, respectively. At an effective airspeed of  $U_\infty=2$  m/s, a barn length greater than  $L=75$  m for this pig fattening example, will require a higher airspeed to maintain temperature control at the  $2^\circ C$  rule level, but the added airspeed designed will not add much further benefit in the way of convective heat transfer (by itself).

**11.8.2 Thermal radiation heat transfer influence on modern barn design**

Consider the case of thermal radiation heat transfer. This mode of sensible heat transfer is often an ignored component of animal/climate interaction because of its difficulty in assessing and understanding. However, it is a vital and in many cases dominant thermal exchange that cannot be ignored. Imagine the following situation. In dairy housing, heat stress control is of paramount concern. Dairy cows are quite content at cold housing conditions, with productivity plummeting at environmental temperatures that exceed about  $25^\circ C$  with milk production efficiency dropping to 50% at  $35^\circ C$  (ASABE, 2006). With an animal this sensitive to heat stress, every possible mechanism must be considered in trying to relieve this stress. In many instances, dairy animals are housed in large open shelters, exposed continuously to the roof of the structure, which are often poorly insulated. This roof serves nicely to reduce the solar load on the animal, but still can represent a potentially high temperature surface that can add to the heat stress level of the cow. For example, assume that a 600 kg cow ( $A_b=0.14(600)^{0.57}$ ; Brody, 1945) is standing in a shelter, with its back surface temperature ( $T_{cow}=36^\circ C$ ) exposed to the roof of the shelter. If this roof is insulated at a level of  $1.0 m^2 - ^\circ C/W$  (moderate) and the roof has an absorptivity to short-wave solar energy of 0.80, and the outside ambient temperature is  $35^\circ C$  with an inside barn air temperature of  $36^\circ C$ , the inside temperature of the roof that the backs of each dairy cow

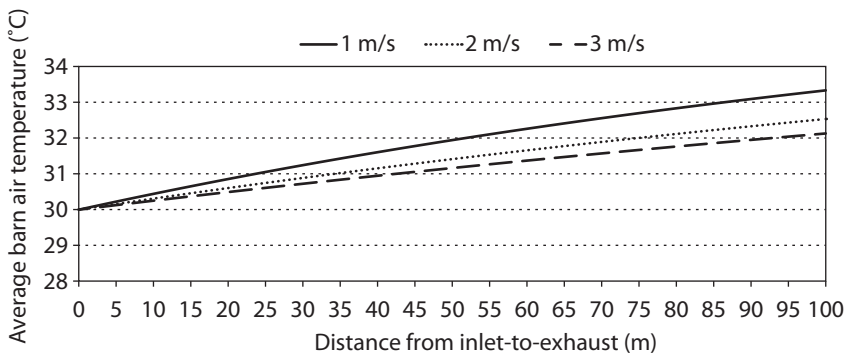

Figure 11.9. Air temperature rise through a tunnel ventilated barn with 100 kg pigs evenly distributed at  $0.70 m^2/pig$  for tunnel airspeeds at 1, 2 and 3 m/s.

## 11. The impact of ventilation and thermal environment

‘radiatively sees’ would be at about 42 °C. The back of each cow is radiatively exchanging energy now with this 42 °C surface. If 2/3 of the total surface area of the cow was exchanging thermal energy with the roof, radiation energy gained by the cow from the roof ( $Q_{r-cow}$ ) would be:

$$Q_{r-cow} = A_b \epsilon_b \sigma (T_r^4 - T_{cow}^4) = \{(2/3) (0.14) 600^{0.57}\} (0.90) (5.67 \times 10^{-8}) (315^4 - 309^4) = 135 \text{ W}$$

If these conditions persisted for a day, the total radiation heat load on the cow *from the roof alone* would be equivalent to 11.7 MJ. This level of *heat load via thermal radiation* represents roughly 10% of the heat loss via evaporation for a cow under these heat stress conditions (Holstein data available at 33 °C; Maia *et al.*, 2005). This is an added load to the cow that is often ignored. In terms of housing strategies to reduce this effect, the exterior roof absorptivity to short-wave solar could be reduced and/or the insulation level of the roof increased. If the roof was doubled in insulation and its exterior absorptivity to short-wave solar was decreased to 0.50, the inside roof temperature would reduce to about  $T_r=38$  °C and the radiation load to the cow from the roof could be reduced to:

$$Q_{r-cow} = A_b \epsilon_b \sigma (T_r^4 - T_{cow}^4) = \{(2/3) (0.14) 600^{0.57}\} (0.90) (5.67 \times 10^{-8}) (311^4 - 309^4) = 45 \text{ W}$$

or 3.9 MJ/day.

Another rather simple method, almost never considered in animal housing, is to place a thermal shield between the animal and the object temperature of concern, in this case the structure’s roof. A thermal shield reduces the ‘radiative viewing’ between the cow and the roof where in general the radiation load to the cow can be reduced by  $(1/(n+1))$  where n is the number of thermal shields placed between the cow and the roof (Holman, 2008). Simply placing one thermal shield between the cow and the roof, with no after-construction changes to the exterior roof material or insulation level, would reduce the radiation heat load to the cow to 68 W (5.9 MJ/day) and two shields would have resulted in a reduction to 45 W (3.9 MJ/day). The point of this exercise is that by understanding the interaction of an animal with its climatic surroundings can give insights into simple and inexpensive techniques for relieving an animal of both heat and cold stress. It is important to note that any thermal shield placed between an animal and another object of concern must not touch either surface, allowing free air movement between shields.

As another example, a common approach for ventilating pig housing is via hybrid ventilation, where thin, low insulating value sidewall curtains are used. For an immature pig in cold climates, radiative exposure to this ‘cold’ surface adds to the cold stress status. Most curtains used in pig housing have an insulating value in the  $R=0.30 \text{ m}^2 - \text{°C}/\text{W}$  range. On a day that is -20 °C, not uncommon in the upper Midwestern region of the US, the inside curtain temperature can be near 9 °C for an inside room air temperature of 20 °C. If 2/3 of a 45 kg pig’s surface area radiatively exchanges with this cold curtain, and the fraction of viewing between the pig and curtain is 0.30, then the total radiation heat loss to this curtain would be:

$$Q_{\text{pig-curtain}} = A_b \epsilon_b \sigma (T_{sk}^4 - T_{\text{curtain}}^4) \\ = \{(2/3) (0.097) 45^{0.633}\} (0.90) (0.3) (5.67 \times 10^{-8}) (310^4 - 282^4) = 37 \text{ W}$$

Over the course of one day, a total of 3.0 MJ/pig-d would be lost to this curtain via thermal radiation. This level represents roughly 25% of the average total heat production for a pig of this size, which has been measured at 12 MJ/pig-d (ASABE, 2006). If cold stressed at these conditions, the pig will move away from cold curtains, thereby decreasing the ‘radiative viewing’ with this cold surface, reducing this influence. A simple remedy to shield the pig from a cold curtain surface is to place a thin film of plastic between the curtain and the room, without touching the curtain, reducing the pig’s thermal radiation loss to the curtain by roughly half.

### 11.8.3 Heat stress and heat transfer influences on modern barn design

Finally, let’s consider the issue of heat stress control for housed animals. The animal industry uses two basic forms of cooling; indirect and direct. Indirect cooling is that method of cooling which first cools the air, allowing the animal to use this cooler air to in turn cool itself via sensible means. In direct cooling, water that resides on an animal’s surface, via natural sweating or artificial sprinkling, is allowed to evaporate thereby allowing the latent heat of vaporization ( $h_{fg}$ ) to be released from the animal. Indirect cooling is probably the most common method for cooling housed animals, although not necessarily the most efficient. Both methods will be discussed for their potential in efficiently cooling the animal.

#### Indirect cooling

Two common methods of indirect cooling are used in animal housing, namely evaporative pad cooling and high-pressure fogging. In both cases, liquid not originating from an animal’s surface, is being used to cool and humidify the air. For evaporative pad cooling, outside air is allowed to come into contact with water for a sufficient contact time allowing water to evaporate thereby cooling the air. The air is cooled since sensible heat from the air is used to provide the latent heat of vaporization ( $h_{fg}$ ) required to evaporate the water. The air, cooled *and subsequently humidified*, is presented to the housed animal for sensible cooling potential.

#### Direct cooling

Direct cooling, as described here, involves the evaporation of water directly from an animal’s surface. In the process of evaporating this moisture, energy equivalent to ( $h_{fg}$ ) is released by the animal. Several models exist to predict this process, ([http://www.engineeringtoolbox.com/evaporation-water-surface-d\\_690.html](http://www.engineeringtoolbox.com/evaporation-water-surface-d_690.html)) one of which is:

$$Q_{\text{surface evap}} = \{(25 + 19 \times U_{\infty}) (A_{\text{wettted}}) \times (W_s - W_{\infty}) / 3,600\} (h_{fg}) (1000) \quad (11.15)$$

where:

- $Q_{\text{surface evap}}$  = energy loss from animal via surface water evaporation (W)
- $U_{\infty}$  = airspeed over wetted surface (m/s)
- $A_{\text{wettted}}$  = actual surface area of animal wetted ( $\text{m}^2$ )
- $W_s$  = saturation humidity ratio evaluated at skin temperature ( $\text{kg}_w/\text{kg}_a$ )
- $W_{\infty}$  = humidity ratio evaluated at surrounding moist air temperature ( $\text{kg}_w/\text{kg}_a$ )
- $h_{fg}$  = latent heat of vaporization, at the current water temperature ( $\text{KJ}/\text{kg}_w$ )

## 11. The impact of ventilation and thermal environment

$$T_{sk} = 2,501 - 2.42 \times T_{sk}$$

$T_{sk}$  = animal skin surface temperature (°C)

As airspeed over the wetted surface increases and the wetted surface area increases, combined with a lowering of the surrounding humidity ratio results in the best potential for direct cooling. Equation 11.15 was developed empirically to predict water loss from pools. This is seemingly a far stretch from use in predicting evaporation rates of water from an animal's surface. To determine the applicability of Equation 11.15, the wetted surface evaporation rate measured from Holsteins (Gebremedhin *et al.*, 2008) was compared against Equation 11.15. Gebremedhin *et al.* (2008) measured  $508 \pm 114$  g/m<sup>2</sup>-h water skin evaporation when subjected to a low airspeed (0.2 m/s) in a 'hot and dry' and no solar load environment and  $961 \pm 252$  g/m<sup>2</sup>-h when the average airspeed was increased to 0.95 m/s. For comparison with Equation 11.15,  $W_s = 0.0412$  kgw/kg (37 °C saturated air at the skin surface) and  $W_a = 0.0139$  kgw/kg (40 °C, 30% RH as 'hot and dry'). At 0.2 m/s, Equation 11.15 predicts an evaporation rate of 786 g/m<sup>2</sup>-h and at 0.95 m/s predicts 1,177 g/m<sup>2</sup>-h; overestimated but reasonable.

### 11.8.4 Indirect vs. direct cooling

An analysis of the potential cooling benefit for the animal will decide on which method, direct or indirect, is best suited for the housed animal. In all cases analyzed, it will be assumed that tunnel ventilation is being used, with a design airspeed over the animal of 2 m/s. Further, it will be assumed that the barn is well insulated and that all surfaces are at the air temperature of the room. Finally, the room is assumed to house 100 kg pigs, modelled as horizontal cylinders ( $D=47$  cm,  $h=5.7$  W/m<sup>2</sup> - °C), with a total body surface area  $A_b = 0.097(100)^{0.633} = 1.8$  m<sup>2</sup>. In addition, these 100 kg pigs will produce latent heat via respiration as a function of surrounding air temperature as  $Q_{resp} = m_{dot,w} \times h_{fg,37\text{ °C}}$ , Equation 11.9 (ASABE, 2006).

#### Case 1. Indirect vs. direct cooling, warm and moderately dry

In this first case, 30 °C and 40% RH outside air enters a 70% efficient evaporative cooler. The air that exits the evaporative cooler, immediately entering the barn, is at 23 °C and 78% RH. Assuming these conditions are present for every animal, the cooling potential for this indirect process would be:

$$Q_{cv} = A_b h (T_{sk} - T_a) = 1.8 \text{ m}^2 (5.7 \text{ W/m}^2 - \text{°C}) (37 - 23) \text{ °C} = 143 \text{ W}$$

$$Q_{rad} = A_b \epsilon_b \sigma (T_{sk}^4 - T_r^4) = (1.8 \text{ m}^2) (0.90) (5.67 \times 10^{-8} \text{ W/m}^2 - \text{K}^4) (310^4 - 296^4) \text{ K}^4 = 144 \text{ W}$$

$$Q_{resp} = (\text{kgw/s-pig}) 2,411 \text{ KJ/kgw} (1000 \text{ J/KJ})$$

$$= (4.2 \times 10^{-8} (23)^2 - 5.7 \times 10^{-7} (23) + 2.9 \times 10^{-5} (2,411) (1000)) = 92 \text{ W}$$

$$Q_{skin\ evap} = 0 \text{ W}$$

$$Q_{total} = (143 + 144 + 92 + 0) = 379 \text{ W}$$



Now, assume that the outside air at 30 °C is brought directly to the animal, but wetting of the animal occurs at a level of 30% of the animal's skin surface area subjected to the same moving airstream of 2 m/s. Under these conditions we have;

$$Q_{cv} = 1.8 \text{ m}^2 (5.7 \text{ W/m}^2 - ^\circ\text{C}) (37-30) ^\circ\text{C} = 71 \text{ W}$$

$$Q_{rad} = A_b \epsilon_b \sigma (T_{sk}^4 - T_r^4) = (1.8 \text{ m}^2) (0.90) (5.67 \times 10^{-8} \text{ W/m}^2 - \text{K}^4) (310^4 - 303^4) \text{ K}^4 = 74 \text{ W}$$

$$Q_{resp} = 4.2 \times 10^{-8} (30)^2 - 5.7 \times 10^{-7} (30) + 2.9 \times 10^{-5} (2,411) (1000) = 123 \text{ W}$$

$$\begin{aligned} Q_{skin \text{ evap}} &= (25 + 19 \times V) (A_{wetted}) \times (W_s - W_a) / 3,600 (2,411) (1000) \\ &= (25 + 19 \times 2) (0.3) (0.097) (100^{0.633}) (W_s - W_a) / 3,600 (2,411) (1000) \\ &= 22,647 (0.0412 - 0.0106) = 693 \text{ W} \end{aligned}$$

$$Q_{total} = (71 + 74 + 123 + 693) = 961 \text{ W}$$

Finally, assume that both indirect and direct cooling is being used to combat the influence of heat stress. Now we have the following:

$$Q_{cv} = 1.8 \text{ m}^2 (5.7 \text{ W/m}^2 - ^\circ\text{C}) (37 - 23) ^\circ\text{C} = 143 \text{ W}$$

$$Q_{rad} = A_b \epsilon_b \sigma (T_{sk}^4 - T_r^4) = (1.8 \text{ m}^2) (0.90) (5.67 \times 10^{-8} \text{ W/m}^2 - \text{K}^4) (310^4 - 296^4) \text{ K}^4 = 144 \text{ W}$$

$$\begin{aligned} Q_{resp} &= (\text{kgw/s-pig}) 2,411 \text{ KJ/kgw} (1000 \text{ J/KJ}) \\ &= 4.2 \times 10^{-8} (23)^2 - 5.7 \times 10^{-7} (23) + 2.9 \times 10^{-5} (2,411) (1000) = 92 \text{ W} \end{aligned}$$

$$\begin{aligned} Q_{skin \text{ evap}} &= (25 + 19 \times V) (A_{wetted}) \times (W_s - W_a) / 3,600 (2,411) (1000) \\ &= (25 + 19 \times 2) (0.3) (0.097) (100^{0.633}) (W_s - W_a) / 3,600 (2,411) (1000) \\ &= 22,647 (0.0412 - 0.0138) = 621 \text{ W} \end{aligned}$$

$$Q_{total} = (143 + 144 + 92 + 621) = 1000 \text{ W}$$

In the case of indirect cooling alone, the increase in sensible heat loss via convection and thermal radiation were minimal compared with the increase in evaporative heat loss from direct cooling alone. When indirect and direct cooling was combined, a moderate increase in total heat loss was predicted.

*Case 2. Indirect vs. direct cooling, warm and very dry*

In this second case, 30 °C and 10% RH outside air enters a 70% efficient evaporative cooler. The air that exits the cooler, immediately entering the barn, is at 18 °C and 58% RH. Assuming these conditions are present for every animal, the cooling potential for this indirect process would be:

$$Q_{cv} = 1.8 \text{ m}^2 (5.7 \text{ W/m}^2 - ^\circ\text{C}) (37 - 18) ^\circ\text{C} = 194 \text{ W}$$

## 11. The impact of ventilation and thermal environment

$$Q_{\text{rad}} = A_b \epsilon_b \sigma (T_{\text{sk}}^4 - T_r^4) = (1.8 \text{ m}^2) (0.90) (5.67 \times 10^{-8} \text{ W/m}^2 - \text{K}^4) (310^4 - 291^4) \text{ K}^4 = 189 \text{ W}$$

$$\begin{aligned} Q_{\text{resp}} &= (\text{kgw/s-pig}) 2,411 \text{ KJ/kgw} (1000 \text{ J/KJ}) \\ &= 4.2 \times 10^{-8} (18)^2 - 5.7 \times 10^{-7} (18) + 2.9 \times 10^{-5} (2,411) (1000) = 77 \text{ W} \end{aligned}$$

$$Q_{\text{skin evap}} = 0 \text{ W}$$

$$Q_{\text{total}} = (194 + 189 + 77 + 0) = 460 \text{ W}$$

Now, assume again that the 30 °C outside air is brought directly to the animal, but wetting of the animal occurs at a level of 30% of the animal's skin surface area subjected to a moving airstream of 2 m/s. Under these conditions we have;

$$Q_{\text{cv}} = 1.8 \text{ m}^2 (5.7 \text{ W/m}^2 - \text{°C}) (37 - 30) \text{ °C} = 71 \text{ W}$$

$$Q_{\text{rad}} = A_b \epsilon_b \sigma (T_{\text{sk}}^4 - T_r^4) = (1.8 \text{ m}^2) (0.90) (5.67 \times 10^{-8} \text{ W/m}^2 - \text{K}^4) (310^4 - 303^4) \text{ K}^4 = 74 \text{ W}$$

$$Q_{\text{resp}} = 4.2 \times 10^{-8} (30)^2 - 5.7 \times 10^{-7} (30) + 2.9 \times 10^{-5} (2,411) (1000) = 123 \text{ W}$$

$$\begin{aligned} Q_{\text{skin evap}} &= (25 + 19 \times V) (A_{\text{wetted}}) \times (W_s - W_a) / 3,600 (2,411) (1000) \\ &= (25 + 19 \times 2) (0.3) (0.097) (100^{0.633}) (W_s - W_a) / 3,600 (2,411) (1000) \\ &= 22,647 (0.0412 - 0.0026) = 874 \text{ W} \end{aligned}$$

$$Q_{\text{total}} = (71 + 74 + 123 + 874) = 1,142 \text{ W}$$

Finally, assume that both indirect and direct cooling is being used to combat the influence of heat stress. Now we have the following:

$$Q_{\text{cv}} = 1.8 \text{ m}^2 (5.7 \text{ W/m}^2 - \text{°C}) (37 - 18) \text{ °C} = 194 \text{ W}$$

$$Q_{\text{rad}} = A_b \epsilon_b \sigma (T_{\text{sk}}^4 - T_r^4) = (1.8 \text{ m}^2) (0.90) (5.67 \times 10^{-8} \text{ W/m}^2 - \text{K}^4) (310^4 - 291^4) \text{ K}^4 = 189 \text{ W}$$

$$\begin{aligned} Q_{\text{resp}} &= (\text{kgw/s-pig}) 2,411 \text{ KJ/kgw} (1000 \text{ J/KJ}) \\ &= (4.2 \times 10^{-8} (18)^2 - 5.7 \times 10^{-7} (18) + 2.9 \times 10^{-5} (2,411) (1000) = 77 \text{ W} \end{aligned}$$

$$\begin{aligned} Q_{\text{skin evap}} &= (25 + 19 \times V) (A_{\text{wetted}}) \times (W_s - W_a) / 3,600 (2,411) (1000) \\ &= (25 + 19 \times 2) (0.3) (0.097) (100^{0.633}) (W_s - W_a) / 3,600 (2,411) (1000) \\ &= 22,644 (0.0412 - 0.0075) = 763 \text{ W} \end{aligned}$$

$$Q_{\text{total}} = (194 + 189 + 77 + 763) = 1,223 \text{ W}$$

Once again, with indirect cooling alone, the increase in sensible heat loss was minimal compared with the increase in evaporative heat loss from direct cooling alone. When indirect and direct cooling was combined, a moderate increase in total heat loss was observed.

*Case 3. Indirect vs. direct cooling, hot and moist*

In this third case, 35 °C and 60% RH outside air enters a 70% efficient evaporative cooler. The air that exits the cooler, immediately entering the barn, is at 30 °C and 87% RH. Assuming these conditions are present for every animal, the cooling potential for this indirect process would be:

$$Q_{cv} = 1.8 \text{ m}^2 (5.7 \text{ W/m}^2 - \text{°C}) (37 - 30) \text{ °C} = 71 \text{ W}$$

$$Q_{rad} = A_b \epsilon_b \sigma (T_{sk}^4 - T_r^4) = (1.8 \text{ m}^2) (0.90) (5.67 \times 10^{-8} \text{ W/m}^2 - \text{K}^4) (310^4 - 303^4) \text{ K}^4 = 74 \text{ W}$$

$$Q_{resp} = 4.2 \times 10^{-8} (30)^2 - 5.7 \times 10^{-7} (30) + 2.9 \times 10^{-5} (2,411) (1000) = 123 \text{ W}$$

$$Q_{skin \text{ evap}} = 0 \text{ W}$$

$$Q_{total} = (71 + 74 + 123 + 0) = 268 \text{ W}$$

Now, assume that the outside air is brought directly to the animal, but wetting of the animal occurs at a level of 30% of the animal's skin surface area subjected to a moving airstream of 2 m/s. Under these conditions we have;

$$Q_{cv} = 1.8 \text{ m}^2 (5.7 \text{ W/m}^2 - \text{°C}) (37 - 35) \text{ °C} = 21 \text{ W}$$

$$Q_{rad} = A_b \epsilon_b \sigma (T_{sk}^4 - T_r^4) = (1.8 \text{ m}^2) (0.90) (5.67 \times 10^{-8} \text{ W/m}^2 - \text{K}^4) (310^4 - 308^4) \text{ K}^4 = 19 \text{ W}$$

$$Q_{resp} = (4.2 \times 10^{-8} (35)^2 - 5.7 \times 10^{-7} (35) + 2.9 \times 10^{-5} (2,411) (1000) = 152 \text{ W}$$

$$\begin{aligned} Q_{skin \text{ evap}} &= (25 + 19 \times V) (A_{wetted}) \times (W_s - W_a) / 3,600 (2,411) (1000) \\ &= (25 + 19 \times 2) (0.3) (0.097) (100^{0.633}) (W_s - W_a) / 3,600 (2,411) (1000) \\ &= 22,647 (0.0412 - 0.0215) = 446 \text{ W} \end{aligned}$$

$$Q_{total} = (21 + 19 + 152 + 446) = 638 \text{ W}$$

Finally, assume that both indirect and direct cooling is being used to combat the influence of heat stress. Now we have the following:

$$Q_{cv} = 1.8 \text{ m}^2 (5.7 \text{ W/m}^2 - \text{°C}) (37 - 30) \text{ °C} = 71 \text{ W}$$

$$Q_{rad} = A_b \epsilon_b \sigma (T_{sk}^4 - T_r^4) = (1.8 \text{ m}^2) (0.90) (5.67 \times 10^{-8} \text{ W/m}^2 - \text{K}^4) (310^4 - 303^4) \text{ K}^4 = 74 \text{ W}$$

$$Q_{resp} = (4.2 \times 10^{-8} (30)^2 - 5.7 \times 10^{-7} (30) + 2.9 \times 10^{-5} (2,411) (1000) = 123 \text{ W}$$

$$\begin{aligned} Q_{skin \text{ evap}} &= (25 + 19 \times V) (A_{wetted}) \times (W_s - W_a) / 3,600 (2,411) (1000) \\ &= (25 + 19 \times 2) (0.3) (0.097) (100^{0.633}) (W_s - W_a) / 3,600 (2,411) (1000) \\ &= 22,647 (0.0412 - 0.0236) = 399 \text{ W} \end{aligned}$$

$$Q_{\text{total}} = (71 + 74 + 123 + 399) = 667 \text{ W}$$

Once again, with indirect cooling alone, the increase in sensible heat loss was minimal compared with the increase in evaporative heat loss from direct cooling alone. When indirect and direct cooling was combined, a moderate increase in total heat loss was observed.

There is no question that in the second case, with indirect cooling, the surrounding environment will be very comfortable for the employees working in this barn. However, the positive benefit for the animal lies in direct cooling. A worker can certainly tolerate a little discomfort for the short periods required in our facilities today. *The housed animal must always come first.* In some housing systems direct cooling is currently not used or considered. For example broilers and turkeys on litter have not traditionally been cooled directly, due mainly to concerns regarding litter moisture control. In these cases, indirect cooling has been the method of choice. However, clever design changes for these housing strategies could certainly include direct cooling 'stations' where birds could freely choose this option and benefit from this avenue of heat stress control.

One final note regarding direct cooling. In housing systems today where sprinkling and direct cooling are used, the control systems for these systems have not followed the physics of direct cooling. For example, sprinkler control systems for pigs today (and all others this author is aware of), have as user-input options the ability to *increase water application time* as barn temperature increases. The physics of direct cooling does not support this action at all. Why increase water application time when the animal surface area required taking advantage of direct cooling does not change with temperature? A clever direct cooling system would apply water for a fixed time that ensures sufficient area wetting ( $A_{\text{wetted}}$ ) and then monitors the environment ( $T, RH, U_{\infty}$ ) to reapply *this same amount of water after an appropriate water evaporation time*, thereby maximizing direct cooling benefit and potentially saving significant water in the meantime. Physics of animal heat exchange must be allowed to dictate animal housing design and practices.

### 11.9 Summary and conclusions

Understanding animal heat exchange with its environment is a critical step in determining building design features and environmental control strategies for optimum well-being. Animal performance is embedded within their surrounding physical and thermal environment. This article summarized animal housing features and environmental control strategies influencing the thermal comfort and well-being of housed animals. Sensible and latent heat transfer was considered and factors that influenced both, which in turn influence animal comfort and well-being, were discussed at length with calculated predictions used to investigate alternatives to our current housing practices. From an engineering perspective, animal well-being is intimately related to the thermal energy exchange occurring between the animal and its surroundings. Therefore, it is important to understand the relationship between key variables that drive the exchange of energy and barn design characteristics that can be implemented to take advantage of these subtle features.

Details related to the use of well-defined shapes to model animal heat exchange were discussed and comparisons were made with published animal heat exchange data. These models, after

verification of applicability, were then used to investigate subtle features of barn design to improve animal well-being especially as related to heat stress control. Direct vs. indirect cooling potential was discussed at length and example scenarios presented indicate the power of direct animal cooling. Active skin wetting control strategies that monitor the potential for evaporation rates need to be developed to take full advantage of direct animal cooling potential and for possible reductions in cooling water use. The take-home messages from this article are as follows:

- Animal comfort and well-being are directly influenced by the exchange of thermal energy with their surroundings.
- Well-defined shapes (cylinders and spheres) can be used to model animal thermal exchange with reasonable accuracy.
- Models of sensible and latent heat transfer can be used to investigate subtle building design features to maximize animal comfort and well-being, specifically:
  - In terms of sensible heat transfer, thermal radiation heat exchange can easily account for 50% of the total. Any non-contacted surface in a barn different from the animal's surface will invoke thermal radiation heat exchange and efforts should be made to thermally shield the animal from these surfaces such as cold sidewall curtains in pig housing and hot roof structures in dairy housing, just to name two such cases. A careful investigation of a barn will identify these surfaces of importance and simple inexpensive shields should be considered.
  - Convection heat transfer increases with increasing airspeed levels over the animal but at diminishing rates. For a 30 kg pig modeled as a 30 cm diameter cylinder, the convective heat transfer coefficient increases from 2-5 W/m<sup>2</sup> – °C for airspeed increases from 0-1 m/s but only improves to 7 W/m<sup>2</sup> – °C for an increase to 2 m/s. This fact has consequences in tunnel barn design and maximum effective tunnel barn length.
  - In examples given on direct vs. indirect cooling, the predicted direct cooling benefit for the housed animal was superior comparing three distinct temperature/humidity climate combinations. To take full advantage of any cooling mechanism, control strategies that take into account the water evaporation potential of the animal's environment should be taken into account. Current cooling control strategies are not following the physics of water evaporation potential.

## **References**

- Albright, L.D., 1990. Environmental control for animals and plants. ASAE Publishing, St. Joseph, MI, USA.
- Armsby, H.P. and Kriss, M., 1921a. Some fundamentals of stable ventilation. *Agricultural Engineering*, July: 151-155.
- Armsby, H.P. and Kriss, M., 1921b. Some fundamentals of stable ventilation. *Agricultural Engineering*, August: 174-177.
- ASABE, 2006. ASAE Standards 2006. ASAE, St. Joseph, MI, USA.
- Blaxter, K., 1989. Energy metabolism in animals and man. Cambridge University Press, New York, NY, USA.
- Brody, S., Comfort, J.E. and Matthews, J.S., 1928. Further investigations on surface area with special reference to its significance in energy metabolism. *Missouri Agricultural Experiment Station Bulletin 115*, University of Missouri Agricultural Experiment Station, Colombia, MO, USA.

## 11. The impact of ventilation and thermal environment

- Brody, S., 1945. Basal energy and protein metabolism in relation to body weight in mature animals of different species. In: Brody, S. (ed.) *Bioenergetics and growth with special reference to the energetic efficiency complex in domestic animals*. Reinhold Pub, New York, NY, USA, pp. 352-403.
- Brown-Brandl, T.M., Nienaber, J.A. Xin, H. and Gates, R.S., 2004. A literature review of swine heat production. *Transactions of the ASAE* 47(1): 259-270.
- Clark-Kennedy, A.E., 1929. Stephen Hales, D.D., F.R.S.: an eighteenth century biography. Cambridge University Press, Cambridge, UK, 256 pp.
- Eigenberg, R.A., Brown-Brandtl, T. and Nienaber, J.A., 2002. Development of a respiration rate monitor for swine. *Transactions of the ASAE* 45(5): 1599-1603.
- Fuller, M.F., 2004. *The encyclopedia of farm animal nutrition*. CABI Publishing, Wallingford, UK.
- Gebremedhin, K.G., Hillman, P.E. Lee, C.N. Collier, R.J. Willard, S.T. Arthington, J.D. and Brown-Brandl, T.M., 2008. Sweating rates of dairy cows and beef heifers in hot climates. *Transactions of the ASABE* 51(6): 2167-2178.
- Hales, S., 1743. *A description of ventilators*. London, UK.
- Henshaw, N., 1677. *Aero-Chaslinos*. In: Hales, S. (ed.) *A description of ventilators*. London, UK.
- Holman, J.P., 2002. *Heat transfer*, 9<sup>th</sup> ed. McGraw-Hill, New York, NY, USA.
- Holman, J.P., 2008. *Heat transfer*. Ninth edition. McGraw-Hill Publishers, New York, NY, USA.
- James Manufacturing. Co., 1916. *The James way: a book showing how to build and equip a practical up to date dairy barn*. James Manufacturing Co., Fort Atkinson, WI, USA, 313 pp.
- Koenig, F.W., 1994. *Techniques for analyzing mechanically ventilated livestock facilities*. MS Thesis, Iowa State University, Ames, IA, USA.
- Maia, A.S.C., Da Silva, R.G. and Battiston Loureiro, C.M., 2005. Sensible and latent heat loss from the body surface of Holstein cows in a tropical environment. *International Journal of Biometeorology* 50(1): 17-22.
- Mitchell, H.H., 1930. The significance of surface area determinations. *Journal of Nutrition* 2: 441.
- Ocock, C.A., 1908. *The King system of ventilation*. Agricultural Experiment Station Bulletin No. 164. University of Wisconsin. Madison, WI, USA.
- Smith, L.J., 1914. A comparison of the King and Rutherford systems of barn ventilation. *Transactions of the ASAE Annual Meeting*. Madison, WI, USA, pp. 42-56.
- Stapleton, H.N., 1940. Adapting ventilating fans to farm buildings and equipment. *Agricultural Engineering*, 21(9): 341-342.
- Sutton, S., 1744. As reported in *The Mechanics Magazine, Museum, Register, Journal, and Gazette*, No. 1061, Saturday December 9, 1843, pp. 418-425.
- Triewald, M., 1741. As reported in *The Foul and the Fragrant: Odor and the French Social Imagination*, Alain Corbin, 1986. Berg Publishers Limited, pp. 89-111.
- Wood, I.D., 1925. Ventilation systems. *The book of rural life: knowledge and inspiration*, 10: 5829-5831. The Bellows-Durhan Company, Chicago, IL, USA.



## 12. Constructing better piggery buildings by identifying factors contributing to improved thermal control under hot climatic conditions

T. Banhazi<sup>1</sup> and D. Rutley<sup>2</sup>

<sup>1</sup>National Centre for Engineering in Agriculture (NCEA), University of Southern Queensland, West Street, Toowoomba, QLD 4530, Australia; <sup>2</sup>Livestock System Alliance, Roseworthy Campus, University of Adelaide, Roseworthy SA 5371, Australia, [thomas.banhazi@usq.edu.au](mailto:thomas.banhazi@usq.edu.au)

### Abstract

External and internal air temperatures were measured continuously for one year (between January 1999 and December 1999) in 48 piggery buildings in South Australia using self-contained data-loggers with built-in sensors. Data was consolidated to correspond with the four seasons. Regression values between the external and internal temperatures were calculated for individual buildings for each season. Data was also collected on major housing features, including configuration of the buildings and management factors employed in them. The information collected was then analysed to quantify the effects of housing and management factors on the resulting environmental control using a multi-factorial statistical model. The overall mean air temperatures in all buildings corresponding to the four seasons were; 24 °C (summer), 20 °C (autumn), 18 °C (winter), 21 °C (spring) across all buildings. The regression values between external and internal temperatures were affected by the season, type of insulation material used in the buildings, the availability of extra heating or cooling equipment, height of buildings, roof pitch (angle), type of ridge ventilation control employed, stocking density, age of buildings and number of pigs housed per building. The effects of housing and management factors on thermal control capacity of buildings were quantified. These findings should aid the construction of better designed livestock buildings resulting in improved welfare and production efficiency in piggery buildings.

**Keywords:** thermal control, insulation, farm building, statistical models, temperature, ventilation, pigs

### 12.1. Introduction

The production efficiency, reproductive performance and welfare of pigs are all significantly affected by the thermal environment provided inside livestock buildings (Jones and Nicol, 1998; Liberati and Zappavigna, 2007; Seo *et al.*, 2012; Zhang and Barber, 1995b). Reproductive and nutritional efficiency of pigs can be significantly improved by keeping them in the ‘Thermo Neutral Zone’ (TNZ) (Patience *et al.*, 2005; Quiniou *et al.*, 2000). Optimal air temperatures also ensure high embryo survival thus improving the reproductive performance of domesticated animals (Lucas *et al.*, 2000; Wolfenson *et al.*, 2000). The highest acceptable temperature within the TNZ is the Upper Critical Temperature (UCT), while the coldest acceptable temperature is the Lower Critical Temperature (LCT) (Banhazi *et al.*, 2009). Below the LCT pigs have to increase



energy intake and reduce heat loss, in order to maintain their core body temperature (Lemay *et al.*, 2001). Above the UCT pigs will increase evaporative heat loss from their respiratory tract (via panting) and from the skin (via a range of behavioural strategies, such as wallowing), they will also reduce feed intake in order to reduce metabolic heat production (Aarnink *et al.*, 2006; Botermans and Andersson, 1995).

Construction materials and the environmental control systems used in piggery buildings (including insulation, heating and cooling systems) as well as the configuration of the buildings are designed to ensure that the temperature is maintained within the TNZ, given economic constraints. When the temperature can be controlled economically an optimum climate in piggery buildings will be created leading to maximum production efficiency. However, evidence in Australia indicates that the air temperatures in wide range of pig housing facilities are sub-optimal (Buddle *et al.*, 1994), fluctuating widely principally influenced by external temperatures (Banhazi *et al.*, 2008). These studies indicate that optimal management of the thermal environment in piggery buildings has not been achieved or is not economically viable. It is assumed that this lack of thermal control is partially caused by inappropriate construction methods and management of the buildings. In turn, this lack of control is likely to be caused by imprecise identification of factors affecting the thermal control capacity of the buildings under practical farm conditions.

Therefore, this study was designed to build upon the results of these previous studies by quantifying the effects of different building and management factors on the thermal control capacity of the piggery facilities. For the purpose of this study, thermal control was defined as the ability of the buildings to resist changes in the external temperature and thus create an internal thermal environment that is independent of the external temperature. This study was conducted in a large number (48) of piggery buildings to: (1) quantify the extent of temperature variation (or the deficiency in thermal control) in commercial piggery buildings; and (2) to determine optimal/key building features, including building configuration, management and design, required to maximise the thermal control capacity of piggery buildings. This study was aimed at identifying practical improvements to the construction and configuration of commercial piggery buildings, to improve production efficiency and welfare of pigs.

## **12.2. Materials and methods**

This field survey was completed in 1999. Air temperatures were measured in 48 different piggery buildings (9 dry sow, 13 farrowing, 12 weaner and 14 grower/finisher buildings) from 12 farms over an entire year (January to December). Farms in South Australia were located in the Northern, Central and Riverland regions to represent Mediterranean and warm temperate zones. The study buildings included a wide range of design and management options and sites were chosen to provide a representative sample of industry practice in southern Australia. Summary statistics of the building features are presented in Table 12.1. Approximately, 77% of the buildings included in the study were naturally ventilated, while the remaining 23% of buildings incorporated some form of mechanical ventilation.

A standard data collection form was used to record all relevant data describing the management and engineering characteristics of the buildings (Table 12.2). The selection of these factors was

Table 12.1. Key features of study buildings.

Feature	Mean	Range
Age of pigs (weeks)	11.8	17
Age of buildings (years)	14.9	29
Number of sows	838	3,200
Pen size (m <sup>2</sup> )	8.5	143
Building volume (m <sup>3</sup> )	862	5,397
Number of pigs per building space	238	1,774
Building length (m)	25.5	127
Building width (m)	9.4	22
Building height (m)	3.0	1
Stocking density (m <sup>3</sup> per pig)	7.5	34
Roof pitch angle (degree)	20	30
Roof ventilation width (cm)	60	130
Roof ventilation height (cm)	30	100

based on the results of previous studies (Banhazi *et al.*, 2008, 2009, 2010). This information was used to develop predictive models identifying building and management features significantly influencing thermal control capacity of the piggery buildings included in the study.

### 12.2.1 Temperature measurements

Self-contained, battery-operated data-loggers with built-in sensors (Tinytalk-2, Hastings Data-loggers Pty. Ltd., Port Macquarie, Australia) were used to measure air temperature both inside and outside of all buildings (Banhazi *et al.*, 2008). These temperature sensors came with factory calibration. The range of the sensors was -45 °C to +75 °C, with a documented accuracy of ±0.5 at 25 °C. A 72 minute logging interval was selected, which allowed ninety days uninterrupted data collection. The choice of a 72-minute interval was a good compromise between obtaining an accurate environmental record and collecting too much redundant data. Each herd received four one-day visits, corresponding with the four seasons and the data was extracted from the loggers using a portable computer. On each farm one sensor was used to measure outside temperature in one representative location on the farm and an additional four sensors were used to measure internal air temperatures in the geometric centre of four different buildings on the same farm. The sensors were placed as close to pig level as practicable without allowing the pigs to interfere with the instruments, approximately 1.1 to 1.3 m above the pen floor (Banhazi *et al.*, 2008).

### 12.2.2 Data analysis

#### *Quantifying the extent of thermal control deficiency*

The initial method of presenting data was to plot temperature against time so producers could get an appreciation of the thermal performance of their buildings. However, to increase the efficiency

*Table 12.2. Information collected about the study buildings and the fixed effects and covariates considered during the analysis.*

---

Variables collected

Item	Comments
Farm identification	Unique identification number
Building identification	Unique identification number
Date of visit	Day/month/year (season)
Management system	Continuous flow vs. all-in/all-out management
Age of pigs	Weeks
Weight of pigs	Average weight of pigs (kg)
Farm size	Number of sows
Pen size	Length (m), width (m), and area (m <sup>2</sup> )

---

Variables considered in the model developed for temperature control

Fixed effect	Class
Heating	Yes/No
Cooling	Yes/No
Building type	Weaner, grower/finisher, dry sow, or farrowing
Ventilation type	Mechanical, natural
Wall ventilation control type	Automatic, manual, fixed, none
Roof ventilation control type	Automatic, manual, fixed, none
Wall insulation type	Asbestos, sandwich panel, spray-on, polystyrene bats, none
Roof insulation type	Asbestos, sandwich panel, spray-on, polystyrene bats, none
Season	Winter, spring, summer or autumn
Covariate	Unit
Building age	Years
Roof pitch angle	Degree
Roof ventilation width	cm
Roof ventilation height	cm
Number of pigs per building space	Number of pigs
Stocking density	m <sup>3</sup> per pig
Building width	m
Building height	m
Building length	m
Building volume	m <sup>3</sup>

---

of the researchers involved in this study; separate MS Excel® based software was developed in-house to facilitate the processing, presentation and storage of the large amount of data collected. This software computed the average, maximum and minimum values for selected time periods. The percentage of time spent above, below and within the recommended temperature ranges appropriate for the particular age group were also automatically calculated. In order to allow for

comparisons between buildings, identical upper and lower limits were set for similar types of buildings (Pointon *et al.*, 1995). This basic analysis and graphical presentation of the data also served as a feedback report for participating producers. Approximately, 250 individual reports were produced and mailed to participating producers in South Australia throughout the life of the project. Observations, specific to a building, were discussed with relevant producers during farm visits as an extension component of the study.

Based on the raw data, different descriptive statistical analysis was undertaken, including calculation of daily temperature variation (difference between maximum and minimum daily temperatures inside the buildings, averaged over a month) and temperature differentials (differences between mean inside and outside temperatures, averaged monthly) for different buildings. This was used as an indication of the buildings' ability to modify the outside temperature.

### *Determination of key building features influencing the thermal control capacity of the buildings*

The primary aim of the study was to enable researchers to identify the important factors influencing the control capacity of piggery buildings so that improved control methods could be identified. Thus, a general linear model procedure (PROC GLM) was selected to analyse the data, as this statistical method has the capacity to handle unbalanced datasets typically collected under field conditions (SAS, 1989). The output from the analysis is a comprehensive model that could be used when designing new buildings.

The response variable of interest was the regression slope of the outside and inside air temperature. This slope was taken to be an indicator of the extent of building temperature control. Data were analysed in order to explain as much of the variation in the response variable as possible. Variation in the regression slope was explained using a statistical model which tested the factors and covariates listed in Table 12.2. All first order interactions were tested. Due to model size restrictions, no higher-order interactions could be tested. The statistical models were developed from the maximum model tested by sequentially removing (in a stepwise manner) non-significant interactions and effects ( $P < 0.05$ , based on type III estimable functions) until only significant effects and interactions remained. Model development was undertaken using SAS Proc GLM (SAS, 1989), while ensuring that all marginality requirements of the model were met (Nelder, 1977, 1994). The results are presented as mean values ( $\pm$  standard error) of fixed effects and the results of co-variates are reported as best-fit slopes, where relevant.

## 12.3 Results

### **12.3.1 Quantifying the extent of thermal control deficiency**

Summaries of the raw means of internal air temperatures and percentage of time spent in the recommended optimal range by building type (building classification) and season are presented in Table 12.3. Mean temperature values were calculated from the mean building averages.

Recommended thermal ranges used in Australia to describe optimal production environments for weaners, growers/finishers, and lactating and dry sows are 24 °C to 28 °C, 20 °C to 24 °C, 18 °C

Table 12.3. Mean internal air temperature (Av. temp., °C) and time spent within, above and below recommended temperature ranges in South Australian piggery buildings.

		Av. temp. (°C)	% in range	% below	% above
Summer	weaner	26.07	36.39	31.94	31.67
	grow/finish	24.30	29.51	24.33	46.16
	dry sow	22.97	31.35	13.80	54.85
	farrowing	24.63	28.27	8.19	63.54
	grand averages	24.49	31.38	19.57	49.06
Autumn	weaner	22.42	32.08	57.92	10.00
	grow/finish	18.84	26.70	62.84	10.46
	dry sow	17.63	29.89	55.71	14.40
	farrowing	20.89	47.53	23.98	28.49
	grand averages	19.95	34.05	50.11	15.84
Winter	weaner	21.12	31.42	65.01	3.57
	grow/finish	16.43	16.12	82.18	1.70
	dry sow	14.84	15.94	81.57	2.49
	farrowing	19.38	50.64	29.65	19.71
	grand averages	17.94	28.53	64.60	6.87
Spring	weaner	23.10	34.04	54.85	11.12
	grow/finish	20.13	29.67	52.08	18.25
	dry sow	19.34	34.18	41.50	24.32
	farrowing	21.95	45.06	10.23	44.71
	grand averages	21.13	35.74	39.67	24.60

to 22 °C, and 18 °C to 25 °C, respectively (Pointon *et al.*, 1995). In winter, building temperatures were below the optimal range for 65% of the time. The results also indicate that on average, grower/finisher and weaner pigs spent 82% and 65% of the time, respectively, below optimal temperatures. In winter, mean air temperatures of 16.4 °C and 21.1 °C were measured in grower/finisher and weaner facilities, respectively. The mean summer air temperatures for grower finisher and weaner pigs were 24 °C and 26 °C, respectively.

The frequency distribution of the temperature data (Figure 12.1) is used to complement Table 12.3 and provide a visual presentation of the range and extremes of internal air temperatures in traditionally well controlled (farrowing) and loosely controlled (dry sow) buildings. From the frequency analyses, the proportion of time spent within different temperature ranges, can be seen. Together with the information of the time spent above and below the recommended air temperatures, these graphs provide a good measure of the severity of environmental regimes in piggery buildings in Australia.

To further quantify the extent of temperature variation in the buildings; the daily temperature range (difference between minimum and maximum temperatures) were calculated and averaged out for different classes of pigs, over one-month periods (Figure 12.2). It can be seen from the

## 12. Constructing better piggery buildings

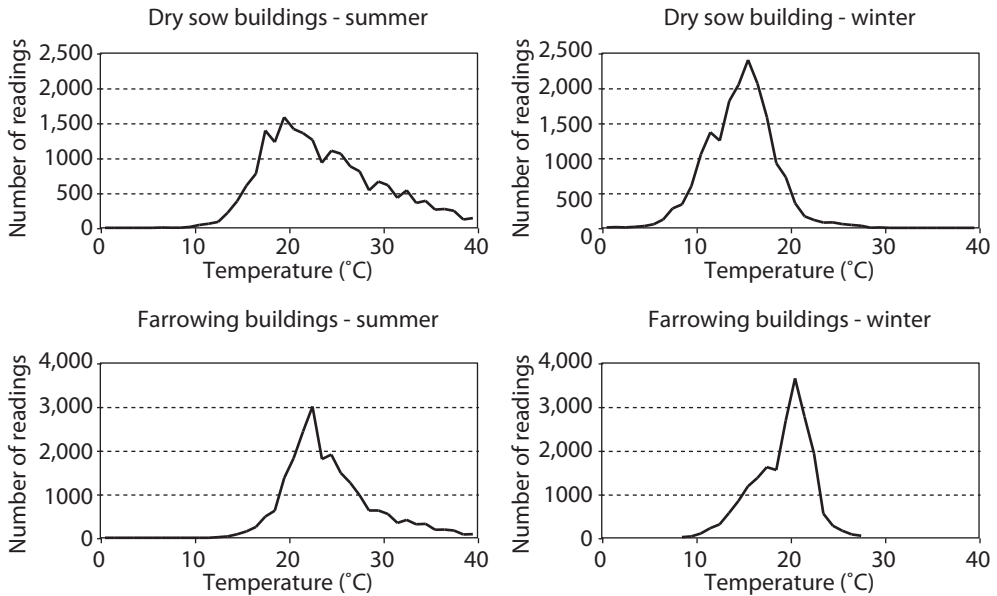

Figure 12.1. Frequency distribution of temperature data collected during the survey in two different types of piggery buildings.

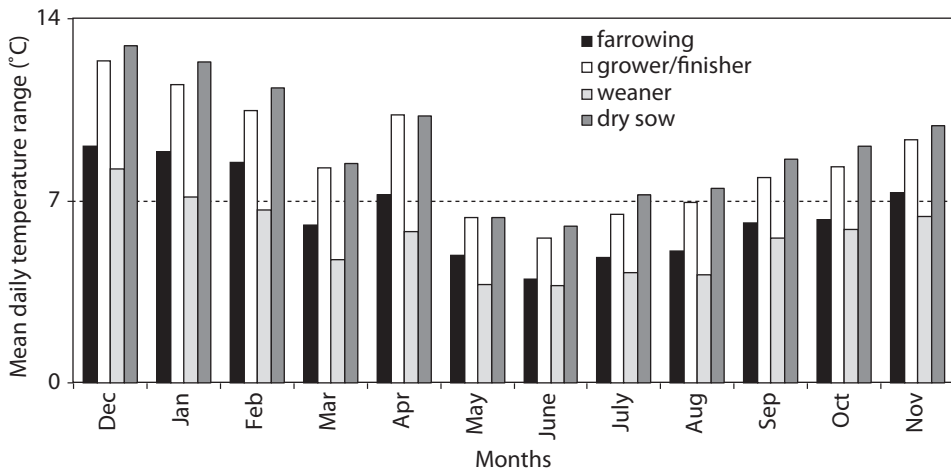

Figure 12.2. Mean daily temperature range in each month in the four major types of piggery buildings.

graph that temperature variations were especially significant in the Australian summer months (December, January and February).

The values for average temperature ‘lifts’ or differentials (difference between daily mean internal and external temperatures) are given in Figure 12.3 for different types of buildings for each month. The data should be interpreted with caution, as the average differential would be influenced by the severity of the outside climate. Nevertheless, this information is a useful guide in evaluating the thermal control capacity of different buildings in different seasons.

It is obvious from the graph that piggery buildings have the greatest capacity to modify outside temperatures during the Australian winter (June, July and August).

**12.3.2 Determination of key building features influencing the thermal control capacity of the buildings**

The summary of the analysis is shown in Table 12.4 and the details are presented in Table 12.5.

Almost 90% of the variation was explained by the model developed for thermal control, which indicated a highly relevant model (Table 12.4). Low numbers of degrees of freedom were used in the models (compared to all available degrees of freedom), which indicate the robustness of the models developed (Table 12.4).

The statistical analysis identified eleven main factors/covariates as having a significant effect on the temperature control capacity of piggery buildings under warm climatic conditions (Table 12.5). For thermal control, the main effects identified were the insulation material used in the

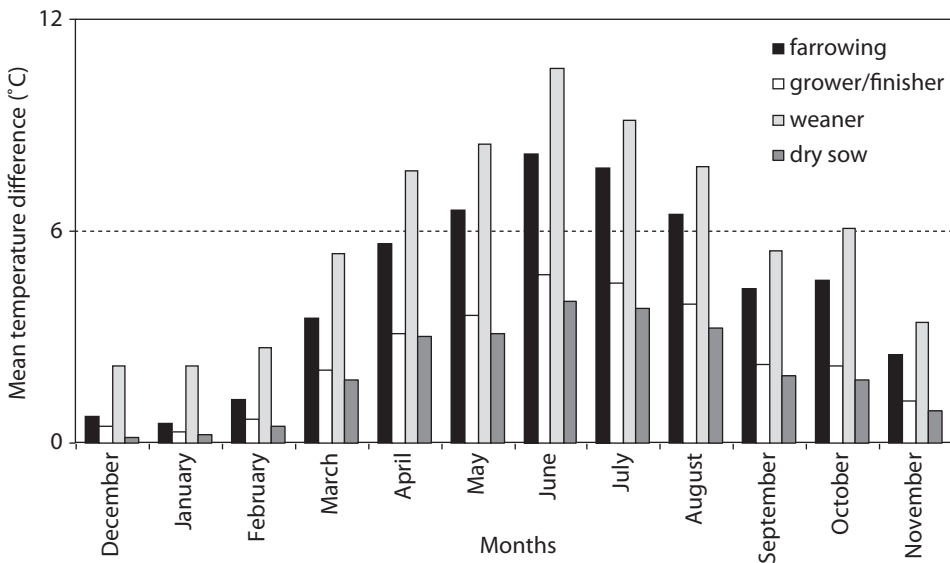

Figure 12.3. Mean temperature difference between inside and outside temperatures measured in South Australian piggery buildings.

## 12. Constructing better piggery buildings

Table 12.4. General Linear Model developed for predicting the temperature control capacity of the piggery buildings ( $R^2=0.899$ ).

Item	Degrees of freedom	Sum of squares	Mean squares	F Statistic	Probability
Model	47	8.709	0.185	26.42	<0.0001
Error	140	0.982	0.007		
Corrected total	187	9.691			

Table 12.5. Factors identified as having a significant effects on the thermal control capacity of piggery buildings.

Significant effects	Sum of squares	F Statistic	Probability value
Wall insulation material	0.399	28.5	0.0001
Cooling	0.062	8.9	0.0033
Heating	0.114	16.3	0.0001
Season (1)	0.175	8.3	0.0001
Shed height (2)	0.145	20.7	0.0001
Roof pitch (3)	0.158	22.6	0.0001
Ridge ventilation control (4)	0.476	33.9	0.0001
Roof insulation material (5)	0.132	9.4	0.0001
Stocking density (6)	0.164	23.4	0.0001
Age of shed (7)	0.035	5.0	0.0266
No. pigs per shed (8)	0.063	9.0	0.0032
Interaction 1*2	0.085	4.0	0.0087
Interaction 3*4	0.170	12.1	0.0001
Interaction 3*5	0.103	4.9	0.0029
Interaction 5*6	0.245	11.6	0.0001
Interaction 5*7	0.244	11.6	0.0001
Interaction 2*4	0.442	31.5	0.0001
Interaction 6*4	0.288	20.5	0.0001
Interaction 5*2	0.135	6.4	0.0004
Interaction 8*5	0.073	3.4	0.0183

buildings, the availability of extra heating or cooling equipment, dimension (height, m) of buildings, seasons, roof pitch angle (degree) of buildings, the type of ridge ventilation control employed, stocking density (kg pig/m<sup>3</sup> airspace), age of buildings (no of years) and number of pigs housed per building (Table 12.5). A number of interactions were also identified.



Figures 12.4-12.9 are graphically representing the predicted influence of these factors on the thermal control capacity of the study buildings. Variables are only presented as single effects, if they were not identified as part of an interaction. A slope approaching 1 unit means that there is little or no thermal control capacity, while a slope approaching 0 units means that there is excellent thermal control capacity.

Asbestos, as expected, has been identified in the analysis as the best insulating material, however it is not used any more in Australia due to occupational health and safety concerns. Among other insulation materials assessed, sandwich panel (Bondor®) sheds had the best insulating properties, while sheds with foam insulation (Spray-on Polyurethane) and poly (Styrofoam® bats) had similar thermal control capacity. Buildings without insulation had significantly lower thermal control capacity than all types of buildings with insulation (Figure 12.4).

The use of either cooling or heating equipment inside piggery buildings significantly improved the thermal control capacity of these buildings (Figure 12.5).

In summer roof height did not affect control capacity; however, the analysis demonstrated that if the internal roof is too high it could undermine the thermal control capacity of the buildings in other (cooler) seasons. Buildings with advanced (automatic) ridge ventilation control again did not benefit from increasing internal building heights, but buildings without ridge ventilation and manually controlled ridge vents slightly benefited from increased internal height of roof (Figure 12.6).

The analysis predicted an overall positive effect of increased roof pitch on the thermal control capacity of buildings, unless the ridge vent was automatically controlled. The model predicted that in sheds with an insulated roof (asbestos is exception) greater roof pitch results in better thermal control capacity. In sheds with no insulation it would have the opposite effect. However, sheds with small roof pitch might benefit from installing an automated ridge ventilation control

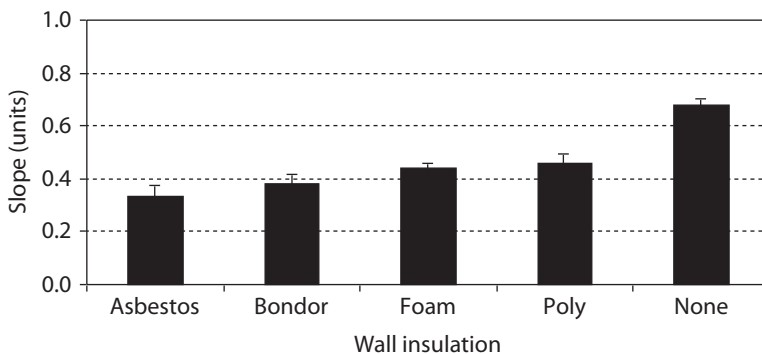

Figure 12.4. Effects of the type of wall insulation on air temperature control in South Australian piggery buildings (mean±standard error).

## 12. Constructing better piggery buildings

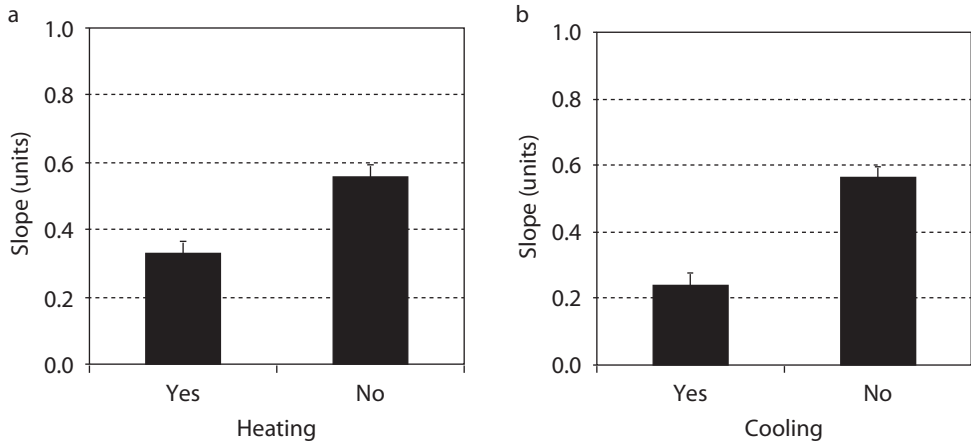

Figure 12.5. Effects of (a) heating and (b) cooling equipment usage on air temperature control in South Australian piggery buildings (mean  $\pm$  standard error).

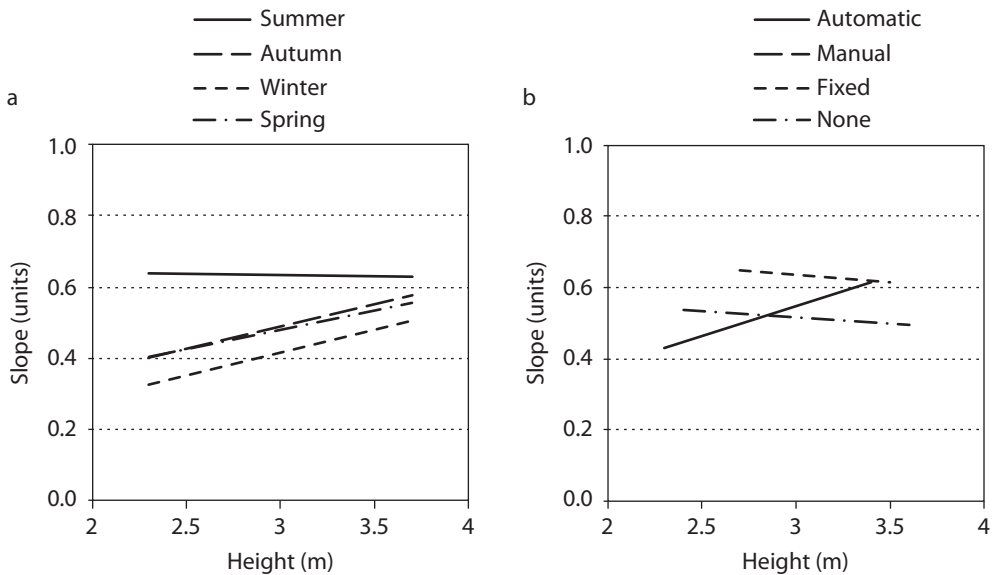

Figure 12.6. Effects of ceiling height in interaction with (a) season and (b) ridge ventilation control method on air temperature control in South Australian piggery buildings (calculated slopes).

system. Increased roof pitch is also helpful in increasing the thermal control capacity of buildings in buildings without adequate ridge vents (Figure 12.7).

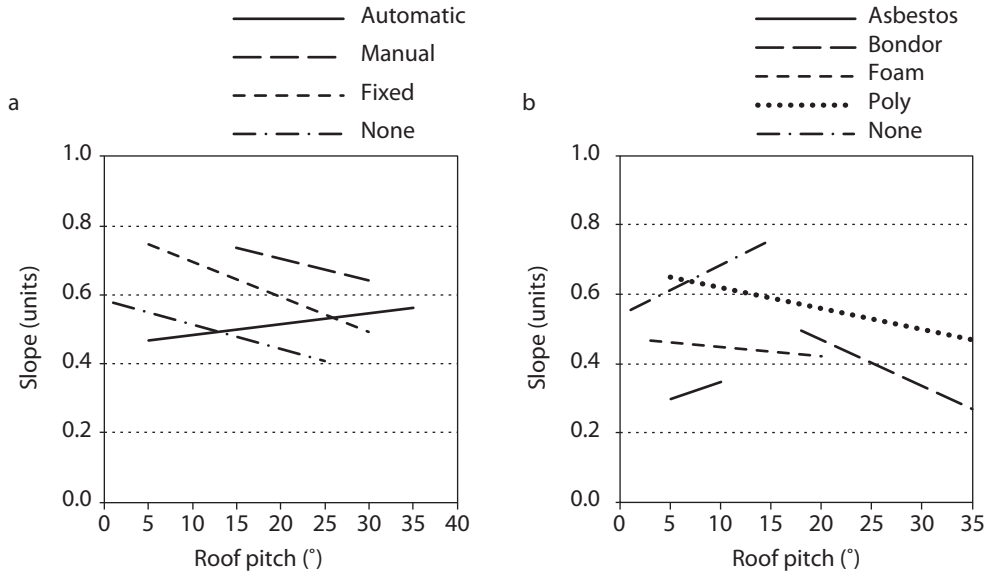

Figure 12.7. Effects of degree of roof pitch in interaction with (a) ridge ventilation control method and (b) roof insulation material type on air temperature control in South Australian piggery buildings (calculated slopes).

Increasing air volume per pig will have a slight positive effect on the thermal control capacity of sheds with Styrofoam® bats (poly) and Spray-on Polyurethane (foam) insulation. However, sheds with no insulation and Bondor® sheds (mostly used for weaner pigs) will not benefit from increased air volume. When the interaction between volume per pig and ridge ventilation control was evaluated, it was found that increasing air volume per pig reduced the thermal control capacity of buildings. However, automatic ridge ventilation control overcame the poor thermal control in sheds with large air volumes per pig (Figure 12.8).

Generally, a larger number of pigs per shed will result in a poorer shed control capacity, although the thermal control capacity of sheds with poly (Styrofoam® bats) insulation improved as the number of pigs per shed increased (Figure 12.9). Further studies will be needed to understand the underlying reasons for this effect.

Temperature control capacity of the buildings deteriorated with age. However, the temperature control capacity of buildings with no insulation changed very little over time. This trend can be related to corrosion, rodent damage and general deterioration of insulating material. The most recently built Bondor® sheds certainly appeared to have an improved thermal control capacity compared to older ones (Figure 12.9).

## 12. Constructing better piggery buildings

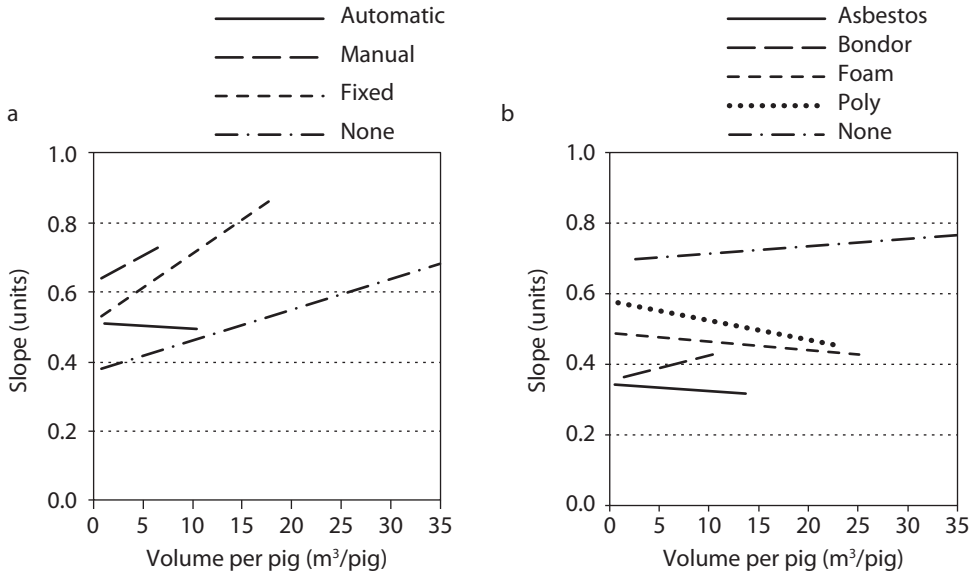

Figure 12.8. Effects of building volume per pig in interaction with (a) ridge ventilation control method and (b) roof insulation material type on air temperature control in South Australian piggery buildings (calculated slopes).

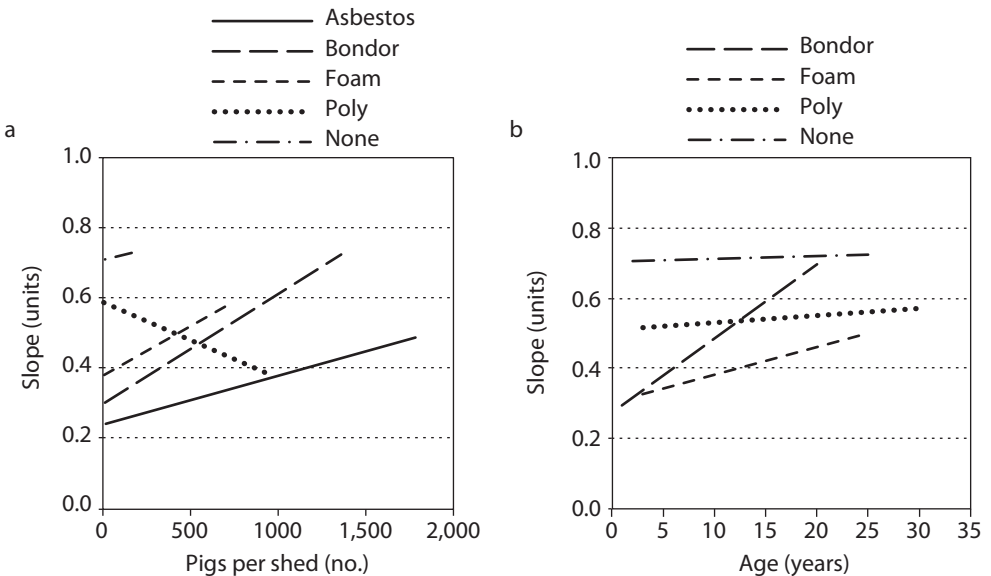

Figure 12.9. Effects of (a) the number of pigs per building and (b) age of building on air temperature control in South Australian piggery buildings (calculated slopes) (in this instance slope for asbestos could not be estimated).

## 12.4 Discussion

### 12.4.1 Assessment of study design and statistical method used

Our specific experimental design and study approach had a number of benefits. First of all, the study was purposely based on statistical modelling to ensure that the results reflect 'real' observed associations and relationships. We believe that our approach ensured that the behaviour of the structures were more objectively assessed when compared to studies using independent engineering equations that may be used out of context. In addition, the long data collection period of the study and the fact that data was collected in a large number of commercial piggery buildings under realistic farm conditions ensured that a realistic assessment of the influence of the housing and management factors could be made.

It was recognised, based on the results of an earlier project (Banhazi *et al.*, 2008), that simple building performance indicators such as average temperatures had limited value when evaluating the thermal control capacity of buildings. Therefore, it was decided to calculate the regression slope for each building per season and use the slopes as indicators of thermal control capacity. Averaging over seasons also ensured that autocorrelation between daily temperatures was not an issue. The reason we have decided to use the regression slope as a measure of thermal control, as the linear regression process quantifies the relationship between two variables. In principle, if the regression slope is close to 1, it would mean that each unit change in outside temperature would result in the same level of change in inside temperature. Therefore, the smaller the slope the greater the difference between the change occurring outside compared to the inside temperature. Thus regression slope was regarded as a good indicator of the relationship between the two variables and ultimately stipulated the level of the temperature control of buildings. To our knowledge, this approach is unique for assessing environmental control of agricultural structures.

### 12.4.2 Quantifying the extent of thermal control deficiency

The study demonstrated a serious thermal deficiency of pig housing in Australia, which needs to be addressed in order to achieve production efficiency targets. All classes of pigs spent a large percentage of their time above or below the optimal thermal range in all seasons, potentially reducing production efficiency, fertility and milk production. Grower/finisher pigs on average spend 82% of their time below optimal temperatures in winter, raising questions about their feed conversion efficiency. As fluctuating and sub-optimal temperatures are risk factors for both enteric and respiratory diseases (Dee *et al.*, 1993; Dennis, 1986; Madec *et al.*, 1998), the findings have both economic and welfare significance.

Different classes of pigs spend approximately 20-30% of their time within the recommended temperature ranges across all seasons. Overall, farrowing buildings appear to have the best controlled internal temperatures, while grower/finisher and dry sow buildings are the poorest performing buildings in terms of thermal control. These findings were not surprising, as producers are generally aware of the adverse impact of sub-optimal temperatures on piglets. However, the data indicates that grower/finisher and to some extent weaner buildings need to be more tightly controlled. Weaner and farrowing buildings are also capable of technically

achieving better thermal control, thus improved management of these buildings is important. In summer, internal air temperatures tend to follow the external values very closely and this pattern reflects typical summer building management. The piggery buildings in hot weather are fully opened in Australia to create higher air speeds. In winter, buildings are closed for a significant amount of time to conserve heat and hence there is a greater difference between internal and external temperatures (Figure 12.3) during the Australian winter months (June, July and August). However, during Australian summer time (December, January and February) when the temperature variation is the greatest (Figure 12.2), piggery buildings have negligible capacity to modify the external air temperatures (Figure 12.3). On the other hand, the lack of thermal control demonstrated in winter (Table 12.3) is most probably related to management problems, as piggery buildings do have considerable capacity to modify the internal temperature during cold periods (Figure 12.3). Such general lack of thermal control capacity of the buildings and appropriate management resulted in buildings spending low percentages of times within specified temperature ranges, especially at critical times of the year (summer and winter).

The graphical representation of the frequency distribution of temperature data provided a visual presentation of the range and distribution of temperature in different piggery buildings and confirmed the existence of a large temperature range in Australian piggery buildings. The calculated daily temperature range figures further proved this point, as considerable daily variation in temperature was observed in all grower and weaner buildings, with values above those recommended by overseas researchers (Madec *et al.*, 1998) for optimal health. It is also important to state that these values are monthly averages for large number of buildings, so individual buildings did perform markedly worse than these average figures (data not shown). This data also underpins the claim of frequently encountered sub-optimal temperatures in piggery buildings in Australia and further strengthen the need for future research in this area.

It could also be argued, that the current thermal environment control systems typically used in Australian piggery buildings are inadequate. Current environmental control systems installed in piggery buildings almost exclusively rely on air temperature to formulate control decisions. However, the thermal environment of intensively housed pigs is also heavily influenced by humidity, skin wetness and air speed (Banhazi *et al.*, 2009; Gates *et al.*, 2001). Air speed has an obvious effect on the thermal comfort of pigs as increased air movement (drafts) increase the lower critical temperature (LCT). In addition, it is reasonable to assume that other factors, such as age of pigs, flooring, stocking rate, nutrition, etc. (Brown-Brandl *et al.*, 2004), will also have a significant effect on how individual animals will be effected by the thermal conditions in the buildings. Therefore, using air temperature exclusively for environmental control in piggery buildings is inadequate and should preferably be replaced by a more advanced control system (Banhazi and Black, 2009). Further research and development would be required to ensure that the influence of other factors are better understood, measured and are taken into consideration, when formulating control decisions in piggery buildings.

### **12.4.3 Determination of key building features influencing the thermal control capacity of the buildings**

A statistical model developed as part of a previous study identified that the most important factor influencing air temperature inside piggery buildings is external temperature, accounting for approximately 67% of the variation in internal temperature (Banhazi *et al.*, 2008). This result indicated that on average only 33% of the variation in temperatures can be controlled by manipulating the engineering features or the management of Australian piggery buildings. This was a very significant finding of the study, as it quantified the thermal control capacity of Australian piggery buildings. As a next logical step, this study identified the main features (construction and management) of piggery buildings that can be used to effectively control the temperature in Australian piggery buildings.

As expected, buildings with insulated roofs demonstrated a greater level of temperature control than un-insulated buildings. Under warm climate conditions, heat loading from solar radiation is a major issue (Brosh *et al.*, 1998; Jeppsson and Gustafsson, 2001). Therefore it was not unexpected that good roof insulation was identified as an important component of well performing piggery buildings. Improving the insulating capacity of buildings, especially roof insulation have to be taken seriously as a first priority, but wall insulation also needs to be improved in Australian buildings. The suggested effects of wall insulation type on air temperature control followed previously identified patterns (Banhazi *et al.*, 2008). These results suggest that buildings with asbestos sheet and sandwich panel insulation experience the highest level of thermal control, while buildings without insulation are the least controlled structures. As demonstrated in previous studies (Banhazi *et al.*, 2008), the thermal environments in weaner buildings are better controlled than in other types of buildings (Table 12.3). Spray-on and poly-bat buildings maintained similar temperature (Figure 12.4).

The model also predicted that the effectiveness of insulation could be easily reduced if it is in poor repair. The demonstrated deterioration of thermal control capacity of the buildings with age is an obvious result of damage and/or aging of insulating material (Figure 12.9). Rodent damage of structural components of the buildings (especially insulating materials) needs to be reduced and the regular maintenance of structural components of buildings needs to be improved. Although, it could not be evaluated within this project, practical experience also demonstrated in the past, that the benefits of good insulation could be negated by not controlling the ventilation. Apart, from the natural deterioration of insulating materials, older buildings also tend to develop problems with air leakage and thus ventilation control (Zhang and Barber, 1995a). The fact that sandwich panel buildings were identified as one of the best performing buildings highlighted the importance of good ventilation control. Sandwich panel buildings are very well sealed as the result of building practices employed during the construction of these types of buildings.

The results also highlight the importance of automatic control of ridge vents as a critical component of good thermal management (Down *et al.*, 1990; Randall, 1980). However, the fact that automatic control of side shutters could not be identified as a statistically significant factor in improving thermal environments in buildings is most likely to due to inappropriate operation of automatic control equipment in buildings. The results demonstrated that greater roof pitch

results in better thermal control capacity of buildings (Down *et al.*, 1990). This is in line with the results demonstrating the importance of ridge vents. It can be assumed that greater level of roof pitch most probably facilitates the functioning of the ridge vent, and therefore improves the overall thermal control capacity of buildings (Norton *et al.*, 2010).

Buildings equipped with cooling and/or heating capacity could be expected to perform better than buildings without these management tools (Gates *et al.*, 2001; Lucas *et al.*, 2000). However, the extra investment has to be justified by adequate gains in production efficiency (Zhang and Barber, 1995b).

Both the number of pigs per airspace and the internal building height affect the thermal control capacity of buildings. Large buildings are more difficult to control thermally and one of the likely benefits of having smaller compartment for batches of pigs is the improved thermal control capacity of the buildings (Boon, 1978; Zhang and Barber, 2000). Increasing the internal building height had a predicted general negative effect on the thermal capacity of buildings. However, in summer and in some types of buildings, increased height can actually slightly improve the thermal control capacity of piggery buildings (Lally and Edwards, 2001; Norton *et al.*, 2009; Randall and Battams, 1979). The same can be said about stocking densities. Increasing the available airspace in buildings per pig can slightly improve the thermal control capacity of buildings with spray-on and poly-bat insulation; however it could be counterproductive in maintaining thermal conditions if buildings are poorly insulated.

This study confirmed some expectations, as main factors identified were anticipated to influence the thermal control capacity of piggery buildings. However, the quantification of the influence of these factors on thermal control is an important improvement over previous studies. This study is an important step toward the practical enhancement of environmental control in piggery buildings via the identification of risk factors for reduced thermal control. It is obvious from the results that temperature variations are poorly controlled in Australian piggery buildings as a result of the 'open' building design typically favoured in predominantly naturally ventilated livestock buildings. However, it has been documented that reduction of temperature variation in piggery buildings can deliver important health and production benefits (Corcuera *et al.*, 2002; Huynh *et al.*, 2005; Le Dividich and Herpin, 1994; Madec *et al.*, 1998; Pang *et al.*, 2011; Patience *et al.*, 2005). Therefore, it would be valuable to quantify the effect of temperature variations on pig production and welfare under Australian conditions in order to develop more specific management guidelines and to quantify the benefits associated with improved thermal control. When such information becomes available, it will be possible to weigh the costs associated with improved management and construction of building against the likely production efficiency increases and welfare improvements expected from enhanced environmental control. This further highlights the importance of continuous monitoring of livestock production processes and the development of real-time decision-making tools, which will allow producers to implement management changes while taking into consideration the likely economic consequences of such decisions (Banhazi and Black, 2009; Eradus and Jansen, 1999; Frost *et al.*, 1997; Wathes *et al.*, 2008). Current developments being pursued in Australia are aimed at achieving this via the implementation of precision livestock farming techniques.



## **12.5 Conclusion**

Results demonstrated that a large percentage of piggery buildings are not functioning effectively, in terms of maintaining optimum temperature. To find a solution to this problem; a model was developed to explain variation in thermal control capacity of piggery buildings. The model delivered a number of important results. In summary, the following main features were identified to be contributing to the thermal control capacity of buildings under Australian (warm) climatic conditions:

- Good roof insulation was identified to be more important than wall insulation and the results demonstrated the improved performance of insulated buildings.
- Buildings with automatically controlled ridge vents performed better than manually controlled buildings or buildings with fixed or no ridge vents.
- The existence of either heating or cooling equipment in buildings significantly improved the temperature control capacity of piggery buildings.
- In general, the thermal control capacity of piggery building deteriorates with building age.
- Larger buildings, with more pigs housed in them, were shown to be more difficult to control thermally, than smaller buildings.
- In principle, higher roofed buildings and buildings with large airspace are more difficult to control thermally, than smaller air spaces. However, piggery buildings with automatic ridge vents could effectively maintain thermal control in buildings with large airspaces.

Air temperature control is an important component of optimal pig housing. It has been widely assumed that warm climatic conditions require a style of housing different to standard designs used in other (cold climate) countries. Data described in this paper highlights the need for innovative warm climate designs, which should incorporate automated ridge vents, good quality roof insulation, steeper roof pitch and smaller compartments.

## **Acknowledgements**

This project was a collaborative effort and involved the contribution of many people. We wish to particularly acknowledge the contributions of the pig producers involved. We also would like to sincerely thank Dr. C. Cargill, who was instrumental in initiating and obtaining funding for the project; Prof. D. Berckmans and Prof. J. Hartung for their professional advice. The important contributions of Mr. J. Weigel and the financial support of the Australian Pork Limited are also gratefully acknowledged.

## **References**

- Aarnink, A.J.A., Schrama, J.W., Heetkamp, M.J.W., Stefanowska, J. and Huynh, T.T.T., 2006. Temperature and body weight affect fouling of pig pens. *Journal of Animal Science* 84: 2224-2231.
- Banhazi, T.M., Aarnink, A., Thuy, H., Pedersen, S., Hartung, J., Payne, H., Mullan, B. and Berckmans, D., 2009. Review of the consequences and control of high air temperatures in intensive livestock buildings. *Australian Journal of Multi-disciplinary Engineering* 7: 63-78.

- Banhazi, T.M. and Black, J.L., 2009. Precision livestock farming: a suite of electronic systems to ensure the application of best practice management on livestock farms. *Australian Journal of Multi-disciplinary Engineering* 7: 1-14.
- Banhazi, T.M., Rutley, D.L. and Pitchford, W.S., 2010. Validation and fine-tuning of a predictive model for air quality in livestock buildings. *Biosystems Engineering* 105: 395-401.
- Banhazi, T.M., Seedorf, J., Rutley, D.L. and Pitchford, W.S., 2008. Identification of risk factors for sub-optimal housing conditions in Australian piggeries – Part III: Environmental parameters. *Journal of Agricultural Safety and Health* 14: 41-52.
- Boon, C.R., 1978. Airflow patterns and temperature distribution in an experimental piggery. *Journal of Agricultural Engineering Research* 23: 129-139.
- Botermans, J. and Andersson, M., 1995. Growing-finishing pigs in an uninsulated house. 2. Pen function and thermal comfort. *Swedish Journal of Agricultural Research* 25: 73-82.
- Brosh, A., Aharoni, Y., Degen, A.A., Wright, D. and Young, B., 1998. Effects of solar radiation, dietary energy, and time of feeding on thermoregulatory responses and energy balance in cattle in a hot environment. *Journal of Animal Science* 76: 2671-2677.
- Brown-Brandl, T.M., Nienaber, J.A., Xin, H. and Gates, R.S., 2004. A literature review of swine heat production. *Transactions of the ASAE* 47: 259-270.
- Buddle, J.R., Mercy, A.R. and Skirrow, S.Z., 1994. The inability of pig sheds to provide ideal environments. In: Poomvises, P. and Ingkaninun, P. (eds.) *Proceedings of the 13<sup>th</sup> International Pig Veterinary Society Congress, 26-30 June 1994, Bangkok, Thailand*, pp. 431.
- Corcuera, B.D., Hernandez-Gil, R., De Alba Romero, C. and Martin Rillo, S., 2002. Relationship of environment temperature and boar facilities with seminal quality. *Livestock Production Science* 74: 55-62.
- Dee, S.A., Carlson, A.R., Winkelman, N.L. and Corey, M.M., 1993. Effect of management practices on the *Streptococcus suis* carrier rate in nursery swine. *Journal of the American Veterinary Medical Association* 203: 295-299.
- Dennis, M.J., 1986. The effects of temperature and humidity on some animal diseases-a review. *British Veterinary Journal* 142: 472-485.
- Down, M.J., Foster, M.P. and McMahon, T.A., 1990. Experimental verification of a theory for ventilation of livestock buildings by natural convection. *Journal of Agricultural Engineering Research* 45: 269-279.
- Eradus, W.J. and Jansen, M.B., 1999. Animal identification and monitoring. *Computers and Electronics in Agriculture* 24: 91-98.
- Frost, A.R., Schofield, C.P., Beulah, S.A., Mottram, T.T., Lines, J.A. and Wathes, C.M., 1997. A review of livestock monitoring and the need for integrated systems. *Computers and Electronics in Agriculture* 17: 139-159.
- Gates, R.S., Chao, K. and Sigrimis, N., 2001. Identifying design parameters for fuzzy control of staged ventilation control systems. *Computers and Electronics in Agriculture* 31: 61-74.
- Huynh, T.T.T., Aarnink, A.J.A., Gerrits, W.J.J., Heetkamp, M.J.H., Canh, T.T., Spoolder, H.A.M., Kemp, B. and Verstegen, M.W.A., 2005. Thermal behaviour of growing pigs in response to high temperature and humidity. *Applied Animal Behaviour Science* 91: 1-16.
- Jeppsson, K.-H. and Gustafsson, G., 2001. Solar heat load in uninsulated livestock buildings. *Journal of Agricultural Engineering Research* 78: 187-197.
- Jones, R. and Nicol, C.J., 1998. A note on the effect of control of the thermal environment on the well-being of growing pigs. *Applied Animal Behaviour Science* 60: 1-9.

- Lally, J.J. and Edwards, W.M., 2001. Performance differences in swine finishing facilities with natural and tunnel ventilation. *Applied Engineering in Agriculture* 17: 521-526.
- Le Dividich, J. and Herpin, P., 1994. Effects of climatic conditions on the performance, metabolism and health status of weaned piglets: a review. *Livestock Production Science* 38: 79-90.
- Lemay, S.P., Guo, H., Barber, E.M. and Chenard, L., 2001. Performance and carcass quality of growing-finishing pigs submitted to reduced nocturnal temperature. *Transactions of the ASAE* 44: 957-965.
- Liberati, P. and Zappavigna, P., 2007. A dynamic computer model for optimization of the internal climate in swine housing design *Transactions of the ASABE* 50: 2179-2188.
- Lucas, E.M., Randall, J.M. and Meneses, J.F., 2000. Potential for evaporative cooling during heat stress periods in pig production in Portugal (Alentejo). *Journal of Agricultural Engineering Research* 76: 363-371.
- Madec, F., Bridoux, N., Bounaix, S. and Jestin, A., 1998. Measurement of digestive disorders in the piglet at weaning and related risk factors. *Preventive Veterinary Medicine* 35: 53-72.
- Nelder, J.A., 1977. A reformulation of linear models. *Journal of the Royal Statistical Society* 140: 48-77.
- Nelder, J.A., 1994. The statistics of linear models: back to basics. *Statistics and computing* 4: 221-234.
- Norton, T., Grant, J., Fallon, R. and Sun, D.-W., 2009. Assessing the ventilation effectiveness of naturally ventilated livestock buildings under wind dominated conditions using computational fluid dynamics. *Biosystems Engineering* 103: 78-99.
- Norton, T., Grant, J., Fallon, R. and Sun, D.-W., 2010. Assessing the ventilation performance of a naturally ventilated livestock building with different eave opening conditions. *Computers and Electronics in Agriculture* 71: 7-21.
- Pang, Z., Li, B., Xin, H., Xi, L., Cao, W., Wang, C. and Li, W., 2011. Field evaluation of a water-cooled cover for cooling sows in hot and humid climates. *Biosystems Engineering* 110: 413-420.
- Patience, J.F., Umboh, J.F., Chaplin, R.K. and Nyachoti, C.M., 2005. Nutritional and physiological responses of growing pigs exposed to a diurnal pattern of heat stress. *Livestock Production Science* 96: 205-214.
- Pointon, A.M., Cargill, C.F. and Slade, J., 1995. *The good health manual for pigs*. Pig Research and Development Corporation, Canberra, Australia.
- Quiniou, N., Dubois, S. and Noblet, J., 2000. Voluntary feed intake and feeding behaviour of group-housed growing pigs are affected by ambient temperature and body weight. *Livestock Production Science* 63: 245-253.
- Randall, J.M., 1980. Selection of piggery ventilation systems and penning layouts based on the cooling effects of air speed and temperature. *Journal of Agricultural Engineering Research* 25: 169-187.
- Randall, J.M. and Battams, V.A., 1979. Stability criteria for airflow patterns in livestock buildings. *Journal of Agricultural Engineering Research* 24: 361-374.
- SAS, 1989. *SAS/STAT® User's guide, Version 6, Fourth Edition, Volume 2,* Cary, NC: SAS Institute.
- Seo, I.-H., Lee, I.-B., Moon, O.-K., Hong, S.-W., Hwang, H.-S., Bitog, J.P., Kwon, K.-S., Ye, Z. and Lee, J.-W., 2012. Modelling of internal environmental conditions in a full-scale commercial pig house containing animals. *Biosystems Engineering* 111: 91-106.
- Wathes, C.M., Kristensen, H.H., Aerts, J.M. and Berckmans, D., 2008. Is precision livestock farming an engineer's daydream or nightmare, an animal's friend or foe, and a farmer's panacea or pitfall? *Computers and Electronics in Agriculture* 64: 2-10.
- Wolfenson, D., Roth, Z. and Meidan, R., 2000. Impaired reproduction in heat-stressed cattle: basic and applied aspects. *Animal Reproduction Science* 60-61: 535-547.
- Zhang, Y. and Barber, E.M., 1995a. Air leakage and ventilation effectiveness for confinement livestock housing. *Transactions of the ASAE* 38: 1501-1504.

## 12. Constructing better piggery buildings

- Zhang, Y. and Barber, E.M., 1995b. An evaluation of heating and ventilation control strategies for livestock buildings. *Journal of Agricultural Engineering Research* 60: 217-225.
- Zhang, Y. and Barber, E.M., 2000. Commissioning livestock building: the needs and challenges, swine housing, *Proceedings on the First International Conference (October 9-11, 2000)*, Des Moines, Iowa. St. Joseph, MI, USA: ASAE, pp. 76-83.



## **Part 5**

### **Airborne pollutants**



# 13. Control of emissions from livestock buildings and the impact of aerial environment on health, welfare and performance of animals – a review

G. Gustafsson, S. Nimmermark and K-H. Jeppsson

Swedish University of Agricultural Sciences, Department of Rural Buildings, P.O. Box 86, 23053 Alnarp, Sweden; [gosta.gustafsson@slu.se](mailto:gosta.gustafsson@slu.se)

## Abstract

High concentrations of gases and airborne particles often occur in buildings for poultry and pigs which can have adverse effects on the health of both workers and animals. The airborne pollutants mainly have negative effects on respiratory systems which can compromise health and production efficiency of livestock. Emissions of airborne pollutants from animal buildings may also have negative effects on the outdoor environment. There is therefore a demand to reduce the release and concentrations of airborne pollutants in animal buildings. The release of gases and airborne particles in animal buildings is complex process and is influenced by several factors in the building environments. This chapter reviews health effects of airborne pollutants on humans and animals in buildings for poultry and pigs. The different factors and processes influencing the release and concentrations of airborne pollutants are discussed. Factors which influence the release and concentration of ammonia in animal buildings are mainly related to the nitrogen content of feedstuff, exposure of faeces and urine (hygiene levels), manure and air temperatures, ventilation and heat balance. High levels of carbon dioxide are usually an indication of low ventilation rates. The major part of dust in animal buildings is organic. Investigations in pig buildings have shown that the generation of dust is influenced by hygiene levels as well as the number and the weight of pigs. Settling of dust is an important mechanism in the mass balance of dust. A major part of the generated dust settles on different surfaces inside the buildings. Investigations have proved that the activity in pig and poultry buildings has a strong influence on the concentration of dust in the air. A technique that directly can reduce the concentrations of dust is water and oil mixture spraying. In addition, the proper management of risk factors for sub-optimal air quality is the most effective way of reducing airborne pollutant levels in livestock buildings.

**Keywords:** livestock buildings, climate, ammonia, dust, health

## 13.1 Introduction

Intensive livestock production can create a potentially unhealthy environment for stockpersons and animals (Banhazi *et al.*, 2009a). Respiratory diseases have been associated with sub-optimal air quality inside animal buildings (Donham *et al.*, 1989; Von Essen and Romberger, 2003; Zhang *et al.*, 1998).



### **13.1.1 Decreased respiratory health in humans**

Melbostad *et al.* (1997) showed that full-time farmers compared to part-time farmers in livestock production (poultry, pig, dairy and combinations) had a 2-3 fold increased risk for chronic bronchitis. Acute respiratory illness has been reported to be common among pig confinement workers (Donham, 1987, 1995; Tielen *et al.*, 1995). Frequent symptoms are coughing, sputum, phlegm, scratchy throats and runny noses. Von Essen and Romberger (2003) found that pig confinement facility workers often develop respiratory problems secondary to their work.

Decreased respiratory health also appears to be a problem among persons working with poultry (Donham, 1987; Drost and Van den Drift, 1993). Diseases as asthma, chronic bronchitis and organic dust syndrome are prevalent among poultry workers. Studies of poultry workers have shown high rates of acute and chronic respiratory symptoms and changes of expiratory flows, indicating decreased pulmonary functions. Eye irritations are also common among poultry farmers (Melbostad and Eduard, 2001).

### **13.1.2 Exposure to ammonia**

Ammonia produced in animal production may affect the farm workers, as well as the animals. At concentrations usually found in livestock facilities, the primary impact of aerial ammonia is as an irritant of the eyes and respiratory membranes; and is a chronic stressor that can affect the course of infectious disease as well as directly influence the growth of young animals (Curtis, 1983). High water solubility allows ammonia to be absorbed in dust particles and litter, as well as in mucous membranes. Such mechanisms allow it to be deposited in the upper respiratory tract, as well as in mucous membranes (Takai *et al.*, 2002). Ammonia in the respirable fraction of inhaled dust particles may reach the lower parts of the respiratory tract and irritate the organs (Takai *et al.*, 2002). Ammonia also irritates skin, eyes, nose, throat and lungs. High ammonia concentrations above the recommended peak eight hour occupational exposure level value of 20 mg/m<sup>3</sup> for humans (Swedish Work Environmental Authority, 2005) have been measured in some pig and poultry buildings (Groot Koerkamp *et al.*, 1998; Nimmermark *et al.*, 2009). Several countries have introduced threshold limit values (TLV) of 20 mg/m<sup>3</sup> for 8 hours work.

Wathes *et al.* (2004) reported no influence on weight gain and food intake on weaned pigs exposed to 0.6, 10.0, 18.8 and 37.0 mg/m<sup>3</sup> ammonia for five weeks. Done *et al.* (2005) reported pathological responses of weaned pigs which were exposed to ammonia concentrations of 0.6, 10.0, 18.8 and 37.0 mg/m<sup>3</sup> ammonia for five weeks. The health of the pigs was assessed in terms of general pathology, respiratory tract pathology, and microbiology of the nasal cavity, trachea and lung. Examinations revealed minimal gross pathology and widespread minor pathological changes of little significance. Lee *et al.* (2005) evaluated the growth performance and endocrine responses of male weaner pigs (3 to 8 weeks of age) in two different environments (clean and dirty) with ammonia concentrations of 6 and 13 mg/m<sup>3</sup>. The pigs grew faster and consumed more feed in the clean environment and this was associated with reduced plasma cortisol concentrations compared with pigs in the dirty environment. Feed conversion did not differ between the different environments.

### 13. Control of emissions from livestock buildings and the impact of aerial environment

In poultry housing, ammonia is considered to be one of the most harmful gases (Carlile, 1984). The peak occupational health and safety (OH&S) limit values for humans are often exceeded in floor housing systems for laying hens with long time storage of manure (Gustafsson and Martensson, 1990; Hauser and Folsch, 1988; Hillig, 1992; Von Wachenfelt, 1993). These high values are suspected to influence animal welfare (Kristensen and Wathes, 2000; Kristensen *et al.*, 2000). In some cases, as high concentrations as 120 mg/m<sup>3</sup> have been measured (Nimmermark *et al.*, 2009). The major reason for high ammonia concentrations is the large amounts of stored and exposed manure in the buildings.

High ammonia concentrations have been found to affect health, production efficiency, feed conversion and performance of poultry (Canveny and Quarles, 1978; Charles and Payne, 1966; Reece and Lott, 1954). Charles and Payne (1966) showed that a concentration of 100 mg/m<sup>3</sup> ammonia caused reduced release of carbon dioxide and respiration from laying hens. The breathing frequency decreased between 7 and 24% at this concentration. Ambient ammonia levels of 50 mg/m<sup>3</sup> for prolonged periods irritate respiratory airways and predispose poultry to respiratory infections. Development of lesions of keratoconjunctivitis of the eye is associated with ambient ammonia levels above 60 mg/m<sup>3</sup> (Hauser and Folsch, 1988).

Nagaraja (1984) measured a reduced rate of bacterial clearance from the lungs in turkeys exposed to 40 mg/m<sup>3</sup> of ammonia. At concentrations as low as of 20 mg/m<sup>3</sup>, ammonia has been shown to have detrimental effects on the respiratory tract in poultry. Excessive mucous production, matted cilia, and deterioration of normal mucociliary apparatus were found in turkeys exposed to ammonia concentrations as low as 10 mg/m<sup>3</sup> for 7 weeks (Nagaraja, 1983).

A series of experiments at the University of Illinois (Drummond *et al.*, 1980) measured the effects of various levels of aerial ammonia on young pigs. The rate of gain of young pigs was reduced by 12% during exposure of aerial ammonia at 50 mg/m<sup>3</sup>, but no lesions were observed in the respiratory tract. At both 100 and 150 mg/m<sup>3</sup> aerial ammonia, rate of gain was reduced by 30% and tracheal epithelium and nasal turbinates showed lesions. Aerial ammonia at 50 and 75 mg/m<sup>3</sup> reduced the ability of healthy young pigs to clear bacteria from their lungs. At 50 and 100 mg/m<sup>3</sup> aerial ammonia exacerbated nasal turbinate lesions in young pigs infected with *Bordetella bronchiseptica*, but did not further compromise the pig's growth rate (Drummond *et al.*, 1981).

#### 13.1.3 Exposure to dust

Dust in animal buildings is mainly of organic origin. Components of the dust might be biologically active and can cause hypersensitive reactions as well as respiratory diseases. Dust produced in animal production may affect the workers (Donham, 1987; Larsson *et al.*, 1999; Malmberg and Larsson, 1993; Takai and Iversen, 1990; Tielen *et al.*, 1995) as well as the animals (Donham, 1991; Hamilton *et al.*, 1993; Robertson, 1993; Robertson *et al.*, 1990).

The recommended peak OH&S threshold limit value of 5 mg/m<sup>3</sup> for dust (CIGR, 1984) is often exceeded during work operations in floor housing systems for laying hens. Whyte (2002) reported that the average inspirable fraction inhaled by poultry stockmen ranged from 2.1 to 28.5 mg/m<sup>3</sup>

for a complete working day. Larsson *et al.* (1999) reported a tendency to stronger inflammatory reactions in the upper airways among previously non exposed subjects who were exposed for three hours in a loose housing system compared to subjects exposed in a cage rearing system. Inhalable dust levels were approximately 4 mg/m<sup>3</sup> in a loose housing system and 2 mg/m<sup>3</sup> in a cage rearing system. Compared to traditional cage systems, the air in floor housing systems may be more polluted with dust because of high animal activity and the availability bedding material (Drost and Van den Drift, 1992, 1993; Gustafsson and Martensson, 1990; Larsson *et al.*, 1999; Lyngtveit, 1992). Similar trends were identified in deep bedded system for pigs (Banhazi *et al.*, 2008b).

The presence of dust in pig buildings may also create environmental problems (Donham, 1987; Larsson *et al.*, 1993; Malmberg and Larsson, 1993; Takai and Iversen, 1990; Tielen *et al.*, 1995) as well as depressed health status of pigs (Donham, 1991; Hamilton *et al.*, 1993; Robertson, 1993; Robertson *et al.*, 1990). Donham (1987) and Tielen *et al.* (1995) reported that acute respiratory illness is common among pig confinement workers but also among veterinary surgeons specialised on pigs (Tielen *et al.*, 1995). Frequent symptoms are coughing, sputum of phlegm, sore throats, runny noses, burning or watering of eyes, shortness of breath and chest wheezing. (Donham, 1987; Tielen *et al.*, 1995). Takai and Iversen (1990) showed that work in pig buildings caused reduced lung function (FEV<sub>1</sub> and FVC) both among farmers with respiratory symptoms as well as among farmers without any symptom. The reduced lung function was especially pronounced among farmers with asthma. Investigations by Larsson *et al.* (1993) and Malmberg and Larsson (1993) showed that exposure to piggery dust of non-smoking subjects who had never visited a pig confinement building resulted in an intense airway inflammatory reaction and general symptoms, such as fever.

Exposure to pig building dust causes several reactions in the respiratory tract. Most of the reactions are of an allergic type and antibodies are often found in the blood of heavily exposed individuals. Allergies associated with working environments are caused by inhalation of allergens that are of biological origin. Allergic reactions are defined as hypersensitivity reactions to antigens. The term hypersensitivity is applied when immune reactions occur in an exaggerated or inappropriate form.

Donham 's (1991) investigations on pigs have shown correlation between percentage of pig with scars on livers and the concentrations of dust and endotoxin in the air. These investigations also showed increased mortality and reduced weight gain among piglets exposed to dust concentrations higher than 5.2 mg/m<sup>3</sup> but also elevated mortality and prevalence of pneumonia and pleuritis among fattening pigs exposed to dust concentrations higher than 3.7 mg/m<sup>3</sup>. Studies by Robertson (1990) have also shown a relationship between the air quality in pig buildings and the severity of both atrophic rhinitis and enzootic pneumonia of pigs. Hamilton *et al.* (1993) reported that the combination of dust, ammonia and *Pasteurella multocida* induced turbulent atrophy on pigs; combinations of which resulted in an accumulative effect.

Wathes *et al.* (2004) reported that food intake and live-weight gain, but not food conversion efficiency, were lower for weaned pigs exposed to dust concentrations of 5.1 and 9.9 mg/m<sup>3</sup> compared with 1.2 and 2.7 mg/m<sup>3</sup>. The reduction in food intake and live weight was dependent

### 13. Control of emissions from livestock buildings and the impact of aerial environment

on the concentration of dust. Other measures of production supported the overall interpretation that dust concentrations of 5.1 mg/m<sup>3</sup> and higher depress performance. Done *et al.* (2005) reported pathological responses of weaned pigs which were exposed to dust concentrations of 1.2, 2.7, 5.1, or 9.9 mg/m<sup>3</sup> for five weeks. The health of the pigs was assessed in terms of general pathology, respiratory tract pathology, and microbiology of the nasal cavity, trachea and lung. Examinations revealed minimal gross pathology and widespread minor pathological changes of little significance.

The major part of dust in animal buildings is organic (Cambra-López *et al.*, 2010). Investigations (Hartung, 1992) indicated that components of the dust are originating from diverse sources, such as feed, skin, hair and faeces. Investigations (Angst, 1984; Hartung, 1992) have shown that the composition of settled dust and feedstuffs in pig buildings differ considerably regarding crude protein and crude ash levels. Nilsson (1982) reported that the high percentages of the dust particles in pig buildings are respirable (less than 5 µm in diameter). However, it should be noted that this would not be the case on purely weight basis. Gustafsson and Martensson (1990) found that the respirable fraction on weight basis varied between 9-13% in growing-finishing pig buildings.

Several investigations (Gustafsson, 1994; Nilsson, 1982; Pedersen, 1993; Van 't Klooster *et al.*, 1993) have proven that the activity in pig buildings has a strong influence on the concentration of dust in the air. The concentration normally increases during periods when the activity is high, such as during feeding and weighing of the pigs. The influence of feeding technique on the activity of the pigs may have an indirect effect on the dust concentration (Robertson, 1992). Pedersen (1993) has shown that the number of dust particles in the air varies with the same pattern as the signal from an activity sensor.

Nilsson (1982) found that the type of feed (dry or wet) had limited influence on the daily averages of total dust concentrations in growing-finishing pig buildings. However, dust concentrations increased during the feeding time due to an increased animal activity in buildings with both wet and dry feeders. The influence of feeding method on the activity of pigs may have an indirect effect on the dust concentration. Robertson (1993) presented results which show significantly higher dust concentrations at restrictive feeding compared with '*ad libitum*' feeding.

Investigations have shown that the generation of dust is influenced by the number and the weight of pigs (Gustafsson, 1999) as well as by the level of hygiene in pig pens (Banhazi *et al.*, 2008b). Settling of dust is a more important mechanism in the mass balance of dust than ventilation rate. A major part of the generated dust settles on different surfaces inside the buildings. The settling rate of dust is affected by the concentration of dust in the air. The settled amount of dust is also related to the floor area of a stable.

Several investigations (Gustafsson, 1994; Nilsson, 1982; Pedersen, 1993; Van 't Klooster *et al.*, 1993) have proven that the activity in pig buildings has a strong influence on the concentration of dust in the air. The concentration normally increases during periods when the activity is high, such as during feeding and weighing of the pigs. The influence of feeding technique on the activity of the pigs may have an indirect effect on the dust concentration (Robertson, 1992). Pedersen

(1993) has shown that the number of dust particles in the air varies with the same pattern as the signal from an activity sensor.

### 13.1.4 Hydrogen sulphide

Hazardous health effects may arise from exposure of the gas hydrogen sulphide found in animal buildings. The characteristic odour of hydrogen sulphide is detectable by humans at a concentration of  $1 \text{ mg/m}^3$ . The olfactory nerve is paralysed approximately over  $150 \text{ mg/m}^3$ , rendering humans to smell the gas. At lower concentrations ( $20 \text{ mg/m}^3$ ) the gas acts as an irritant to mucous membranes and produces ocular and airway irritations. Exposure to concentrations of  $100 \text{ mg/m}^3$  produces pneumonia and bronchitis.  $250 \text{ mg/m}^3$  leads to pulmonary oedema and depression of central nervous system. Unconsciousness and possible death after 30 minutes exposure will be the effects of exposure to a level of  $500 \text{ mg/m}^3$ . Concentrations of  $700 \text{ mg/m}^3$  are very rapidly fatal, since the gas causes paralysis of the respiratory centre.

Hydrogen sulphide is mainly produced in liquid manure under anaerobic conditions. This gas is mainly released when the manure is agitated. High concentrations can occur when liquid manure is stirred or flushed. It can also be released by air leakages from outside manure storage areas and by high air velocities in manure channels. The reduction of the concentrations of hydrogen sulphide in animal buildings is therefore mainly a question of good management. It is also recommended that there should be a gas trap between the building and storage areas located outside, as depicted in Figure 13.1. It is generally recommended that the building should be ventilated at the highest possible capacity when liquid manure is flushed from the buildings.

### 13.1.5 Carbon dioxide

The usual concentration of carbon dioxide in the outside air is approximately  $380 \text{ mg/m}^3$ . This gas is present at elevated levels in all animal buildings. Resulting from metabolic processes, most carbon dioxide is released via respiration. The amount of carbon dioxide released is related to the

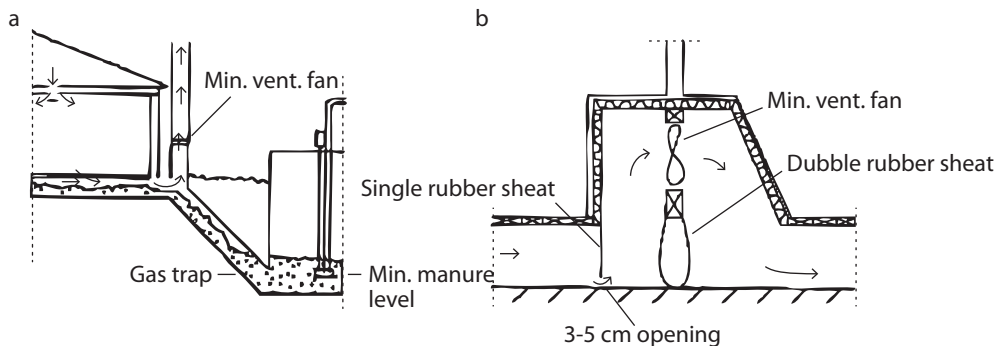

Figure 13.1. Methods of preventing air leakage into a building when manure is handled in (a) liquid or (b) solid state.

## 13. Control of emissions from livestock buildings and the impact of aerial environment

metabolic level of the animals. The concentration of carbon dioxide in animal buildings provides information about the ventilation rate in those buildings (Robertson *et al.*, 1990) and thereby also some indication of the general hygienic quality of the air. It is recommended to keep the concentration of carbon dioxide below 3,000 mg/m<sup>3</sup> (CIGR, 1984).

### 13.2 Emissions

In order to address the environmental problems associated with gas emissions, emission ceiling targets have been put in place at both international and national levels. Animal buildings are an important emission source in the livestock production chain due to the complex nature and diverse number of factors that affect emissions at the level of the building (Banhazi *et al.*, 2008a; Sommer *et al.*, 2006).

#### 13.2.1 Ammonia

During the last half century, an increased nitrogen deposition in the environment has been detected due to atmospheric ammonia. This had a stimulating effect on vegetation growth. The role of ammonia in soil acidification and on other ecological effects has therefore attracted greater attention during recent years. Atmospheric ammonia causes acute toxic injuries to vegetation close to the source and contributes to the large scale nitrogen eutrophication and acidification of ecosystems by long range atmospheric transport of ammonium. The most important source of anthropogenic ammonia in Europe is agriculture, mainly from animal production and fertilizer application (ECETOC, 1994; Fangmeier *et al.*, 1994; Ferm, 1998). The contribution from agriculture is on average 92% (ECETOC, 1994) and about 25% of the nitrogen in animal excretion is lost to the atmosphere in Western Europe (Ferm, 1998).

#### 13.2.2 Greenhouse gases

Anthropogenic emissions of greenhouse gases (GHG) have been associated with climate change which is responsible for the rising temperatures, rising sea levels, receding icecaps and melting permafrost (IPCC, 2001). The contribution of livestock production to GHG generation is substantial, accounting for about 18% of the total anthropogenic greenhouse gas emissions when measured in carbon dioxide equivalent. The most important climate gases that are produced from animal husbandry are methane and nitrous oxide with global warming potentials of 23 and 296 times that of carbon dioxide respectively on a 100 years' time horizon. Dairy cow production represents one of the largest sources of CH<sub>4</sub>, N<sub>2</sub>O and NH<sub>3</sub> within livestock production.

## 13.3 Influences of factors in the building environments

### 13.3.1 Ammonia

The interval between manure removal and storage time of manure influences the amount of exposed manure and thus the release of ammonia. By removing the manure from floor surfaces several times per day (essentially improving hygiene conditions); ammonia emissions can be reduced by removing the source of ammonia before most of it has volatilized (Groenestein,

1994). The statistically significant effect of improved hygiene was identified in piggery buildings in previous studies (Banhazi *et al.*, 2008a,b).

Studies on different lengths of emptying intervals for slurry under slats in fattening pig buildings have shown that the  $\text{NH}_3$  concentration only begins to increase at intervals longer than one day (Gustafsson, 1988). Slurry removal 1-2 times per day is therefore sufficient to prevent an increase in  $\text{NH}_3$  emissions due to slurry storage in pig buildings. After three days of storage,  $\text{NH}_3$  emissions increase by approximately 40%.

According to BREF (2003), vacuum extraction gives higher  $\text{NH}_3$  emissions than mechanical scrapers under slats. Animal housing systems with straw-flow (Amon *et al.*, 2007) or fully straw-bedded pens give higher  $\text{NH}_3$  emissions than systems with partly slatted floors and mechanical scrapers (BREF, 2003). In both Swedish (Gustafsson and Martensson, 1990; Von Wachenfelt, 1993) and overseas studies (Groot Koerkamp *et al.*, 1995; Hauser and Folsch, 1988; Hillig, 1992) loose-housing for hens has been found to cause enhanced concentrations of ammonia in comparison with those in cage systems with regular cleaning-out of manure. The reason for the increased concentrations of ammonia is the larger amount of manure that becomes accumulated inside the buildings when the hens are kept in loose-housing systems. It is possible to keep the ammonia concentration below the occupational exposure limit value if manure is removed daily in a bin below a draining floor (Gustafsson and Von Wachenfelt, 2012). Housing systems with elevated drainage floors should therefore be equipped with manure systems that enable frequent removal of manure.

Urine is the main contributing source of ammonia emissions, but is also difficult to fully remove from a building. A maximum in the emission rate occurs about 1 to 2 hours after the sprinkling of urine on a slatted surface contaminated with faeces (Elzing and Swierstra, 1993; Elzing and Monteny, 1997). Improving the urine drainage reduces the nitrogen content of the manure and hence the ammonia release. An example in a tie stall is a gutter with a 3% slope against a urine drainage channel equipped with an auger is presented in Figure 13.2.

One parameter considerably affecting ammonia release is the temperature in the manure (Aarnink *et al.*, 1993; Andersson, 1995a; Beauchamp *et al.*, 1978; Emerson *et al.*, 1975; Freney *et al.*, 1983;

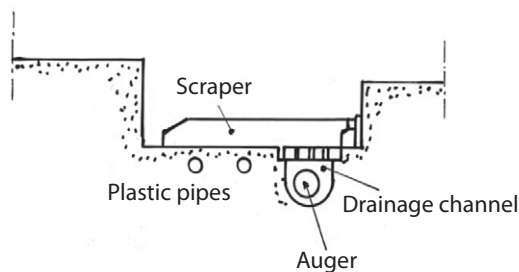

Figure 13.2. A manure gutter with a 3% slope against a urine drainage channel equipped with an auger (Gustafsson *et al.*, 2005).



### 13. Control of emissions from livestock buildings and the impact of aerial environment

Hoeksma *et al.*, 1993; Sommer *et al.*, 1991). The relationship between manure temperature and ammonia emissions follows an exponential pattern (Andersson, 1995a; Hartung *et al.*; 1994; Svensson, 1993) and for manure with a high potential for ammonia release (high concentration of ammonium-N, ammonia-N, and high pH), the ammonia release increases dramatically as the temperature in the manure increases (Figure 13.3). This was also confirmed by other studies that found a relationship between air temperature and ammonia concentrations in livestock buildings (Banhazi *et al.*, 2008b; Groot Koerkamp *et al.*, 1998). Therefore, reductions of ammonia emissions can be expected in animal buildings if the manure temperatures can be kept low.

Measures to reduce ammonia emissions by lowering the manure temperature are reported by Den Brok and Verdoes (1996) and Andersson (1998c). The manure cooling system investigated by Den Brok and Verdoes (1996) was a laminated frame that floated on the top layer of the manure in a fattening pig building. Andersson (1998c) investigated a cooling system with cooling coils mounted in the concrete floor of a manure culvert. Both investigations showed that cooling the manure is an effective measure of reducing ammonia emissions. Investigations have shown that cooling manure through a manure culvert beneath a slatted floor with a heat pump is an effective but expensive measure of reducing ammonia emission. Decreasing the manure channel floor temperature by 4 °C using a heat pump in a pig building resulted in a 47% decrease in ammonia release (Andersson, 1998c). The extracted energy has to be utilized in some way if this technique is to become economical competitive (Andersson, 1998c).

A cheaper way of cooling manure is with the incoming drinking water. An example where plastic pipes were installed in the concrete of a gutter in order to cool the manure is presented in Figure 13.2. In this case the temperature of incoming drinking water increased from 2.6 to 8.1 °C when it passed through the plastic pipes in the bottom of the gutters. The average amount of water passing through the pipes was 85 l/cow/day. Cooling the manure in the cowshed by passing incoming drinking water through pipes in the concrete of the manure gutters reduced the ammonia release, 11-23%, and increased temperature of incoming drinking water which corresponded to 1.4 MJ/

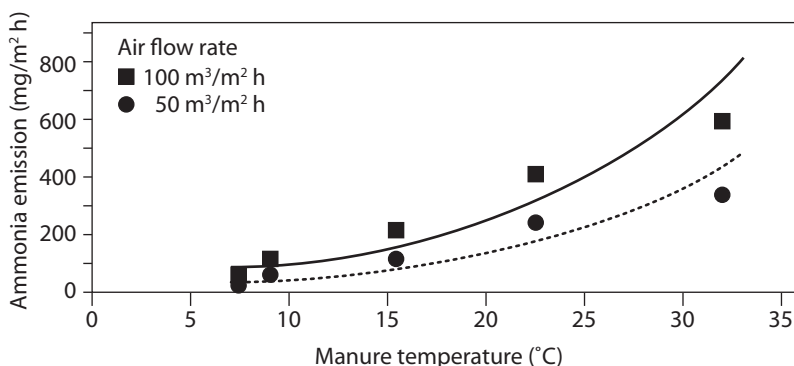

Figure 13.3. Ammonia emission from cow slurry depending on the manure temperature (after Andersson, 1995a).



cow/day (Gustafsson *et al.*, 2005). In the Netherlands a system has been developed where cooling plates float on the surface of slurry under slats. They are cooled with groundwater (Den Brok and Verdoes, 1996). The system has been developed for use in pig buildings with slurry storage in channels under the slats. In a building with partly slatted concrete floor, slurry storage under slats and cooling plates, NH<sub>3</sub> emissions were reduced by 50% compared with a reference system (BREF, 2003).

The temperature of the surrounding air influences the ammonia release directly by affecting the mass transfer at the liquid-air boundary and indirectly by affecting the temperature of the manure surface. Investigations in laboratory (Andersson, 1995a; Elzing and Monteny, 1997) and in livestock buildings (Ni *et al.*, 1999; Oldenburg, 1989) have reported increase of ammonia release with increasing air temperature. By cooling incoming air on warm days and thus decreasing air flow and lowering air temperature, NH<sub>3</sub> emissions can be decreased.

The ventilation rate over a manure surface affects the ammonia concentration difference between the liquid phase in the manure surface and the gas phase in the surrounding air. Several researchers (Andersson, 1995a; Hartung *et al.*, 1994; Katyal and Carter, 1989; Rank, 1988; Svensson, 1993) have shown in laboratory investigations and in livestock buildings with slatted floors (Aarnink *et al.*, 1993; Ni *et al.*, 1999), increasing ammonia release with increasing ventilation rates.

In a livestock building, temperature conditions and ventilation rate will influence the release of ammonia in different ways dependent on the heat balance. The ventilation rate will be approximately inversely proportional to the difference between inside and outside air temperatures. This fact will mean that the temperature level inside the building and ventilation rate will influence ammonia release in opposite ways. An increased temperature level inside the building at a certain outdoor temperature will decrease the ventilation rate and reverse.

The air velocity around a manure surface will influence the mass transfer in the liquid-air boundary. The influence of air velocity on ammonia emission in a pig building is presented in Figure 13.4.

Measures to avoid high air velocities on exposed floor surfaces are mainly proper design and location of air inlets which creates low air velocities. It is also important to maintain low air movements in manure culverts. The air velocities in a manure culvert depend on the depth of the culvert. The influence of depth of a culvert on ammonia release is presented in Figure 13.5. Ammonia release decreases with increasing depth.

Treatment of exhaust air from livestock buildings with biofilters has mainly been developed for reduction of odours in exhaust air. However, ammonia removal efficiencies of 64 to 93% in exhaust air have been reported (Sheridan *et al.*, 2002).

A biofilter is a layer of organic material (often a mixture of wood chips or wood shreds and compost) where the exhaust air is forced through the material (Schmidt *et al.*, 2004). Active bacteria growing in the material break down compounds in the air passing through the layer (Hoyer *et al.*, 2000). Key factors influencing the performance of a biofilter is the moisture

### 13. Control of emissions from livestock buildings and the impact of aerial environment

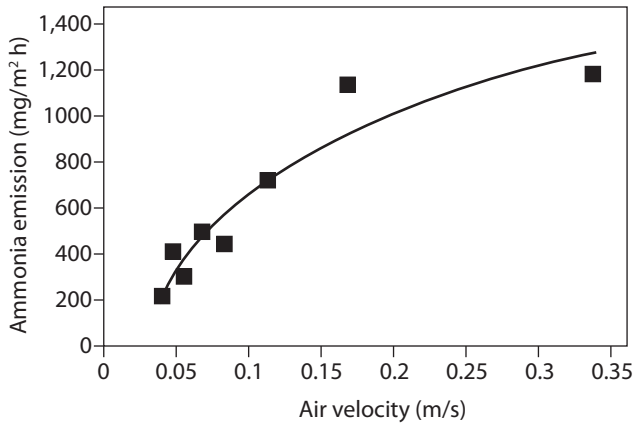

Figure 13.4. Ammonia emission depending on air velocity in a pig building (Andersson, 1995b).

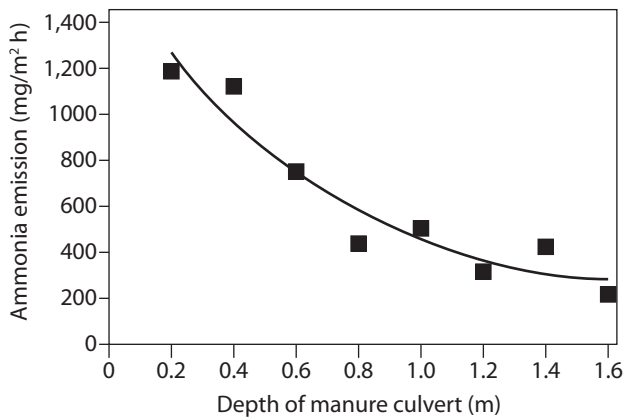

Figure 13.5. Ammonia emission depending on the depth of a manure culvert (Andersson, 1995b).

content and the contact time of the air with the material (Nicolai *et al.*, 2004; Schmidt *et al.*, 2004). For design purposes the contact time is expressed as the empty bed contact time (EBCT). Recommended contact times are in the range 3-10 seconds (Schmidt *et al.*, 2004). Hoyer *et al.* (2000), suggest a bottom area of 0.0055 m<sup>2</sup> for every m<sup>3</sup>/h ventilation rate.

Kim *et al.* (2000) compared two organic and two inorganic packing materials with regard to the removal of ammonia gas in a biofilter inoculated with sludge. The organic packing materials showed superior performance for the removals of ammonia in the concentration range of 0-300 mg/m<sup>3</sup> as compared to the inorganic packing materials. Martens *et al.* (2001) compared the potential of five different biofilter materials (biochips, coconut-peat, wood-bark, pellets-bark and compost) to reduce ammonia emission from a pig facility. No relationship with regard to

ammonia reduction efficiency could be established between the different biofilter materials. Gabriel *et al.* (2007) investigated the performance of coconut fibre as packing material in the removal of ammonia in gas-phase biofilters. Biological activity of coconut fibre and biofilter performance were assessed during operation of a pilot-scale biofilter under steady-state and transient conditions at inlet ammonia concentrations in the range of 45-300 mg/m<sup>3</sup> and gas contact times of 19-36 seconds. Reduced efficiencies were related to low water content in the packed bed of the biofilter. A maximum elimination capacity of 12 g NH<sub>3</sub>/m<sup>3</sup>/h at 80% removal efficiency was found for a non-acclimated biofilter under transient conditions. A higher watering of the coconut fibre, as well as an acclimated biomass allowed an elimination capacity of 33.3 g NH<sub>3</sub>/m<sup>3</sup>/h at a 100% removal efficiency. Lim *et al.* (2012) tested two elevated-bed wood-chip biofilters for effectiveness in mitigating ammonia emissions. Two trials were conducted to test the effects of biofilter thickness which included 127 mm and 254 mm media thicknesses. The two biofilters with 127 mm media thickness reduced ammonia concentrations with 31.2% ( $P \leq 0.5$ ) and 18.1% ( $P \geq 0.5$ ). The biofilters with 254 mm media thickness significantly ( $P \leq 0.5$ ) reduced ammonia concentrations by 45.8% and 18%.

### 13.3.2. Dust

Several investigations (Gustafsson, 1994; Nilsson, 1982; Pedersen, 1993; Van 't Klooster *et al.*, 1993) have proved that the activity in pig buildings has a strong influence on the concentration of dust in the air. The concentration normally increases during periods when the activity is high, such as during feeding and weighing of pigs. The influence of feeding technique on the activity of the pigs may have an indirect effect on the dust concentration (Robertson, 1992). Pedersen (1993) has shown that the number of dust particles in the air varies with the same pattern as the signal from an activity sensor.

It should further be mentioned that an international survey about airborne pollutants in buildings for laying hens (Tielen *et al.*, 1995) has shown large differences in dust concentrations between cage systems and different alternative housing systems. The concentration of dust is generally higher in alternative systems, probably due to an increased activity. These results were confirmed by a recent study conducted in Australia (Banhazi *et al.*, 2008c).

The types of housing systems influence the generation of dust. Gustafsson (1999) compared two different housing systems for growing pigs, namely: a climate controlled confinement in an insulated piggery and a cold confinement in an un-insulated piggery with straw bedding and natural ventilation. Significant differences occurred between the different piggeries. The presence of dust was much lower in the un-insulated stable with straw bedding, probably because of presence of more moisture in this housing system. The dust reduction effects of high humidity in bedded system was also identified statistically in a recent study (Banhazi *et al.*, 2008b).

There is little consensus among investigations about the influence of ventilation rate on dust concentrations. However, investigations (Bundy and Hazen, 1975) about the influence of ventilation rate on the number of dust particles have shown a decrease in number of dust particles at increasing ventilation rate. The influence of ventilation rate on total mass concentration of dust in the air has been less pronounced (Gustafsson, 1994; Nilsson, 1982). The influence of ventilation

### 13. Control of emissions from livestock buildings and the impact of aerial environment

rate on total dust concentrations in a pig building is indicated in Figure 13.6. Investigations have also indicated influence of different ventilation techniques on dust concentrations (Van 't Klooster *et al.*, 1993).

The type of ventilation technique may influence concentration of respirable particles. Gustafsson (1999) compared two very different ventilation principles in buildings for growing pigs, namely; high speed re-circulating air inlets in combination with an exhaust fan located at roof level (high exhaustion) and a porous ceiling as the air inlet in combination with manure gas ventilation (low exhaustion). Significant differences occurred regarding respirable dust concentrations which were lowest at low air velocities. These results indicate that the ventilation technique (mainly air velocities and air movements) may have an influence on small particles. Similar results have been reported by Banhazi *et al.* (2008b).

Air cleaning has limited effect on the dust concentration in the air, even if an air cleaning equipment removes a large fraction of the particles in the air which passes through the device. Air cleaning devices need to have large airflow capacities if the dust concentration in the air is to be affected. The airflow through an air cleaner has the same influence on the dust concentration as an equally large increase in ventilation rate in the building.

Gustafsson (1999) compared three types of spraying nozzles in an automatic spraying system namely: high pressure (ultra sound) nozzles; flat fan nozzles; and full cone nozzles. The nozzles were operated automatically in short sequences. They were operated twice per hour from 8 a.m. until 6 p.m. and once per hour during the rest of the day. Spraying water droplets gave different results depending on the type of nozzles which were used. The use of ultra sound nozzles which created droplets in the size range between 5 and 10  $\mu\text{m}$  resulted in a significant increase of both total and respirable dust concentrations during nine comparative trials. The reason for the increased dust concentrations was probably the ultra sound (frequency 30 kHz) created by

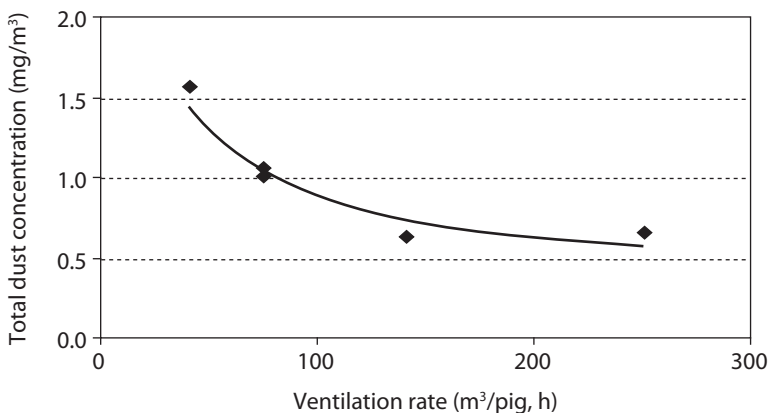

Figure 13.6. Example of influence of ventilation rate on total dust concentration in a pig building (Gustafsson, 1999).

the nozzles. This sound was outside of the human hearing range. However, observations of the pigs clearly showed that the pigs reacted in an abnormal way the first times the nozzles were in operation. The increased dust concentrations may be explained by an increased activity of the pigs due to the ultra sound. The use of flat fan nozzles operated with a pressure of 0.35 MPa gave a reduction in both total and respirable dust concentrations. In these trials, each pen was equipped with four (horizontal spraying direction) flat fan nozzles in combination with a full cone nozzle (orientated downwards). The use of full cone nozzles operated at 0.3 MPa pressure also reduced both total and respirable dust concentrations.

### 13.3.3 Treatment with oil

Takai and Pedersen (1999) proved that the spraying of mixtures of oil and water will give significant reductions in dust concentrations in buildings for pigs. Their investigations showed dust reduction rates of 50 to 90%. The basic idea is to spray a little amount of oil, which is just enough to bind dust particles, so that they do not disperse from surfaces. The oil concentration in oil-water mixtures should be higher than 20%. Droplet sizes greater than 150 µm are desired. In general, all kinds of vegetable oil, which are available with reasonable prices, can be used for dust binding purposes. Results demonstrated that oil/water mixture spraying or impregnation can be used effectively to reduce dust concentrations in different livestock building with bedding materials. Similar results have been reported by Banhazi *et al.* (2011). Thus this technology should be promoted within the farming community.

## 13.4 Conclusions

High concentrations of gases (mainly ammonia) and dust in buildings for laying hens and pigs can adversely affect the health and welfare of both workers and animals. Emissions of atmospheric ammonia cause acute toxic injuries to vegetation close to the source and contribute to the large scale nitrogen eutrophication and acidification of ecosystems by long range atmospheric transport of ammonium. Methods to reduce the release of ammonia in livestock buildings are mainly: (1) frequent removal of faeces and urine; (2) improvement of general hygiene; (3) prevention of air leakages into manure culverts; (4) low air velocities in manure culverts; and (5) cooling of manure in culverts. Reducing dust concentrations may need special abatement techniques as spraying water droplets in the air or spraying mixtures of oil and water on the floors of livestock buildings.

## References

- Aarnink, A.J.A., Wagemans, M.J.M. and Keen, A., 1993. Factors affecting ammonia emission from housing for weaned piglets. In: Verstegen, M.W.A., Den Hartog, L.A., Van Kempen, G.J.M. and Metz, J.H.M. (ed.) Nitrogen flow in pig production and environmental consequences. Pudoc Scientific Publishers, Wageningen, the Netherlands, pp. 286-294.
- Amon, B., Kryvoruchko, V., Fröhlich, M., Amon, T., Pöllinger, A., Mösenbacher, I. and Hausleitner, A., 2007. Ammonia and greenhouse gas emissions from a straw flow system for fattening pigs: housing and manure storage. *Livestock Science* 112: 199-207.
- Andersson, M., 1995a. Ammonia volatilization from cow and pig manure. Sveriges lantbruksuniversitet, institutionen för jordbrukets biosystem och teknologi, Report 98, Lund, Sweden, 66 pp.

### 13. Control of emissions from livestock buildings and the impact of aerial environment

- Andersson, M., 1995b. The effect of different manuring systems on ammonia emissions in pig buildings. Sveriges lantbruksuniversitet, institutionen för jordbrukets biosystem och teknologi, Report 100, Lund, Sweden, 41 pp.
- Andersson, M., 1998c. Reducing ammonia emissions by cooling of manure culverts. *Nutrient Cycling in Agroecosystems* 51: 73-79.
- Angst, C., 1984. Zur Zusammensetzung des Staubes in einem Schweinemaststall [Composition of dust in a fattening pig house]. PhD thesis, Hannover School of Veterinary Medicine, Hannover, Germany.
- Banhazi, T.M., Currie, E., Quartararo, M. and Aarnink, A.J.A., 2009a. Controlling the concentrations of airborne pollutants in broiler buildings. In: Aland, A. and Madec, F. (eds.) *Sustainable animal production: the challenges and potential developments for professional farming*. Wageningen Academic Publishers, Wageningen, the Netherlands, pp. 347-364.
- Banhazi, T.M., Currie, E., Reed, S., Lee, I.B. and Aarnink, A.J.A., 2009b. Controlling the concentrations of airborne pollutants in piggery buildings. In: Aland, A. and Madec, F. (eds.) *Sustainable animal production: the challenges and potential developments for professional farming*. Wageningen Academic Publishers, Wageningen, the Netherlands, pp. 285-311.
- Banhazi, T.M., Saunders, C., Nieuwe, N., Lu, V. and Banhazi, A., 2011. Oil spraying as an air quality improvement technique in livestock buildings: development and utilisation of a testing device. *Australian Journal of Multi-disciplinary Engineering* 8(2): 169-180.
- Banhazi, T.M., Seedorf, J., Laffrique, M. and Rutley, D.L., 2008c. Identification of risk factors for high airborne particle concentrations in broiler buildings using statistical modelling. *Biosystems Engineering* 101(1): 100-110.
- Banhazi, T.M., Seedorf, J., Rutley, D.L. and Pitchford, W.S., 2008a. Identification of risk factors for sub-optimal housing conditions in Australian piggeries. Part IV: Emission factors and study recommendation. *Journal of Agricultural Safety and Health* 14: 53-69.
- Banhazi, T.M., Seedorf, J., Rutley, D.L. and Pitchford, W.S., 2008b. Identification of risk factors for sub-optimal housing conditions in Australian piggeries. Part II: Airborne pollutants. *Journal of Agricultural Safety and Health* 14(1): 21-39.
- Beauchamp, E.G., Kidd, G.E. and Thurtell, G., 1978. Ammonia volatilization from sewage sludge applied in the field. *Journal of Environmental Quality* 7(1): 141-146.
- BREF, 2003. Reference document on best available techniques for intensive rearing of poultry and pigs. European integrated pollution preventing and control bureau. Available at: <http://eippcb.jrc.es/pages/factivities.htm>.
- Bundy, D.S. and Hazen, T.E., 1975. Dust levels in swine confinement systems associated with different feeding methods. *Transactions of the ASAE* 18(1): 137-139.
- Cambra-López, M., Aarnink, A.J.A., Zhao, Y., Calvet, S. and Torres, A.G., 2010. Airborne particulate matter from livestock production systems: A review of an air pollution problem. *Environmental Pollution* 158(1): 1-17.
- Canveny, D. and Quarles, C.L., 1978. The effect of atmospheric ammonia stress on broiler performance and carcass quality. *Poultry Science* 57: 1124-1125.
- Carlile, F.S., 1984. Ammonia in poultry houses: a literature review. *World Poultry Science* 40: 99-113.
- Charles, D.R. and Payne, C.G., 1966. The influence of graded levels of atmospheric ammonia on chickens. *British Poultry Science* 7: 177-198.
- CIGR, 1984. Aerial environment in animal housing. Concentrations in and emissions from farm buildings. Working Group Report Series No 94.1.

- Curtis, S.E., 1983. Environment management in animal agriculture. Iowa State University Press, Ames, IA, USA, pp. 266-268.
- Den Brok, G.M. and Verdoes, N., 1996. Effect van mestkoeling op de ammoniakemissie uit een vleesvarkensstal [The effect of manure cooling on the ammonia emission from a fattening pig house]. Research Institute for Pig Husbandry, Report P1.155, Rosmalen, the Netherlands. 28 pp. (In Dutch; English summary).
- Done, S.H., Chennells, D.J., Gresham A.C.J., Williamson, S., Hunt, B., Taylor, L.J., Bland, V., Jones, P., Armstrong D., White, R.P., Demmers, T.G.M., Teer, N. and Wathes, C.M., 2005. Clinical and pathological responses of weaned pigs to atmospheric ammonia and dust. *Veterinary Record* 3(157): 71-80.
- Donham, K.J., 1995. Health hazards of pork producers in livestock confinement buildings: from recognition to control. In: McDuffie, H.H., Dosman., J.A., Semchuk, K.M., Olenchock, S.A. and Senthilselvan, A. (eds.) *Agricultural health and safety – workplace, environment, sustainability*. Lewis Publishers/CRC Press, Boca Raton, FL, USA, pp. 43-48.
- Donham, K.J., 1987. Human health and safety in livestock housing. Proceedings: CIGR-seminar Latest development in livestock housing. American Society of Agricultural Engineers, St. Joseph, MI, USA, pp. 86-93.
- Donham, K.J., 1991. Association of environmental air contaminants with disease and productivity in swine. *American Journal of Veterinary Research* 52(10): 1723-1729.
- Donham, K., Haglund, P., Peterson, Y., Rylander, R. and Belin, L., 1989. Environmental and health studies of farm-workers in Swedish swine confinement buildings. *British Journal of Industrial Medicine* 46(1): 31-37.
- Drost, H. and Van den Drift, D.W., 1992. Working conditions in an aviary system for laying hens, World's Poultry Congress, Amsterdam, the Netherlands 20-24 September, Proceedings Vol 2: pp. 734-738.
- Drost, H. and Van den Drift, D.W., 1993. Health effects in relation to exposure to aerial components in aviary systems for layers, Proceedings XXV CIOSTA CIGR Congress, May 10-13, 1993, Wageningen, the Netherlands, pp. 198-204.
- Drummond, J.G., Curtis, S.E., Simon, J. and Norton, H.W., 1980. Effects of aerial ammonia on growth and health of young pigs. *Journal of Animal Science* 50(6): 1085-1091.
- Drummond, J.G., Curtis, S.E., Meyer, R.C., Simon, J. and Norton, H.W., 1981. Effects of atmospheric ammonia on young pigs experimentally infected with *Bordetella bronchiseptica*. *American Journal of Veterinary Research* 42(6): 963-968.
- ECETOC, 1994. Ammonia emissions to air in Western Europe. European Centre for Ecotoxicology and Toxicology of Chemicals, Report 62, Brussels, Belgium, 196 pp.
- Elzing, A. and Monteny, G.J., 1997. Ammonia emission in a scale model of a dairy-cow house. *Transactions of the ASAE* 40: 713-720.
- Elzing, A. and Swierstra, D., 1993. Ammonia emission measurements in a model system of a pig house. In: Verstegen, M.W.A., Den Hartog, L.A., Van Kempen, G.J.M. and Metz, J.H.M. (eds.) *Nitrogen flow in pig production and environmental consequences*. Pudoc Scientific Publishers, Wageningen, the Netherlands, pp. 280-285.
- Emerson, K., Russo, R.C., Lund, R.E. and Thurston, R.V., 1975. Aqueous ammonia equilibrium calculations: Effect of pH and temperature. *Journal of the Fisheries Research Board of Canada* 32: 2379-2383.
- Fangmeier, A., Hadwiger-Fangmeier, A., Van der Eerden, L. and Jäger, H-J., 1994. Effects of atmospheric ammonia on vegetation – a review. *Environmental Pollution* 86: 43-82.
- Ferm, M., 1998. Atmospheric ammonia and ammonium transport in Europe and critical loads: a review. *Nutrient Cycling in Agroecosystems* 51: 5-17.



### 13. Control of emissions from livestock buildings and the impact of aerial environment

- Freney, J.R, Simpson, J.R. and Denmead, O.T., 1983. Volatilization of ammonia. In: Freney, J.R. and Simpson, J.R. (eds.) Gaseous loss of nitrogen from plant-soil systems. Martinus Nijhoff, The Hague, the Netherlands, pp. 1-33.
- Gabriel, D., Maestri, J.P., Martin, L., Gamisans, X. and Lafuente, J., 2007. Characterisation and performance of coconut fibre as packing material in the removal of ammonia in gas-phase biofilters. *Biosystems Engineering* 97 (4): 481-490.
- Groenestein, C.M., 1994. Ammonia emission from pig houses after frequent removal of slurry with scrapers. International Conference on Agricultural Engineering (AgEng '94), Merelbeke, Belgium, pp. 543-550.
- Groot Koerkamp, P.W.G., Keen, A., Van Niekerk, T.G.C.M. and Smit, S., 1995. The effect of manure and litter handling and indoor climatic conditions on ammonia emissions from a battery cage and an aviary housing system for laying hens. *Netherlands Journal of Agricultural Science* 43: 351-373.
- Groot Koerkamp, P.W.G., Metz, J.H.M., Uenk, G.H., Phillips, V.R., Holden, M.R., Sneath, R.W., Short, J.L., White, R.P., Hartung, J., Seedorf, J., Schröder, M., Linkert, K.H., Pedersen, S., Takai, H., Johnsen, J.O. and Wathes, C.M., 1998. Concentrations and emissions of ammonia in livestock buildings in northern Europe. *Journal of Agricultural Engineering Research* 70: 79-95.
- Gustafsson, G., 1988. Air and heat balances in animal houses, Swedish University of Agricultural Sciences, Department of Farm Buildings, Report 59, Lund, Sweden, 385 pp. (In Swedish).
- Gustafsson, G., 1994. Efficiency of different dust reducing methods in pig houses. Proceedings: 12<sup>th</sup> CIGR Conference, 5-8 September 1994, Milan, CIGR, Merelbeke, Belgium, pp. 551-558.
- Gustafsson, G., 1999. Factors affecting the release and concentration of dust in pig houses. *Journal of Agricultural Engineering Research* 74: 379-390.
- Gustafsson, G. and Mårtensson, L., 1990. Gases and dust in poultry houses, Swedish University of Agricultural Sciences, Department of Farm Buildings, Report 68, Lund, Sweden, 88 pp. (In Swedish).
- Gustafsson, G. and Von Wachenfelt, E., 2012. Reduced ammonia release by daily removal of manure below draining floors in a floor housing system for laying hens. *Journal of Agricultural Science and Technology*. David Publishing Company, El Monte, CA, USA. JAST-E11100804.
- Gustafsson, G., Jeppsson, K.-H., Hultgren, J. and Sanno, J.-O., 2005. Techniques to reduce the ammonia emission from a cowshed with tied dairy cattle. *Agricultural Engineering International: The CIGR Ejournal*, Vol VII, BC 04 010.
- Hamilton, T.D.C., Roe, J.M., Taylor, F.G.R., Pearson, G. and Webster, A.F.J., 1993. Aerial pollution: an exacerbating factor in atrophic rhinitis of pigs. Proceedings: Livestock Environment IV, ASAE, St. Joseph, MI, USA, pp. 895-903.
- Hartung, E., Büscher, W., Jungbluth, T., 1994. Basic research on the ammonia release in livestock production using liquid manure. AgEng '94, Report N. 94-C-007, Milan, Italy, 8 pp.
- Hartung, J., 1992. Emissionen luftgetragener Stoffe aus Nutztierställen [Emissions of airborne substances for livestock buildings]. *Pneumologie* 46: 196-202.
- Hauser, R.H. and Folsch, D.W., 1988. Methods for measuring atmospheric ammonia in poultry houses: Review and approved practices. *Journal of Veterinary Medicine* 35: 579-593.
- Hillig, J., 1992. Ammoniakemissionen aus Aufzucht- und Legehennen-ställen bei unterschiedlichen Haltungsverfahren, In: Geruchs- und Schadgasemissionen aus der Tierhaltung, Arbeitspapier 174, KTBL, Darmstadt, pp. 74-79.
- Hoeksma, P., Verdoes, N. and Monteny, G.J., 1993. Two options for manure treatment to reduce ammonia emission from pig housing. In: Verstegen, M.W.A., Den Hartog, L.A., Van Kempen, G.J.M. and Metz, J.H.M. (ed.) Nitrogen flow in pig production and environmental consequences. Pudoc Scientific Publishers, Wageningen, the Netherlands, pp. 301-306.



- Hoyer, S., 2000. Biofilter project smells of success. Odor and Nutrient Management Newsletter. Iowa State University, Ames, IA, USA.
- IPCC, 2001. Third assessment report climate change. The scientific basis. Intergovernmental Panel on Climate Change, Geneva, Switzerland.
- Katyal, J.C. and Carter, M.F., 1989. Effects of air flow rate, leaching, and presubmergence on ammonia volatilization and apparent denitrification loss of nitrogen from a submerged soil. *Soil Science* 147: 116-125.
- Kim, N.-J., Hirai, M. and Shoda, M., 2000. Comparison of organic and inorganic packing materials in the removal of ammonia gas in biofilters. *Journal of Hazardous Materials* 72(1): 77-90.
- Kristensen, H.H. and Wathes, C.M., 2000. Ammonia and poultry welfare: a review. *World's Poultry Science* 56(3): 235-245.
- Kristensen, H.H., Burgess, L.R., Demmers, T.G.H. and Wathes, C.M., 2000. The preferences of laying hens for different concentrations of atmospheric ammonia. *Applied Animal Behaviour Science* 68(4): 307-318.
- Larsson, B.-M., Larsson, K., Malmberg, P., Martensson, L. and Palmberg, L., 1999. Airway responses in naïve subjects to exposure in poultry houses: comparison between cage rearing systems and alternative rearing system for laying hens. *American Journal of Industrial Medicine* 35: 142-149.
- Lee, C., Giles, L.R., Bryden, W.L., Downing, J.L., Owens, P.C., Kirby, A.C. and Wynn, P.C., 2005. Performance and endocrine responses of group housed weaner pigs exposed to the air quality of a commercial environment. *Livestock Production Science* 93(3): 255-262.
- Lim, T.-T., Jin, Y., Ni, J.-Q. and Heber, A.J., 2012. Field evaluation of biofilters in reducing aerial pollutant emissions from a commercial pig finishing building. *Biosystems Engineering* 112 (3): 192-201.
- Lyngtveit, T., 1992. Stovmalning og arbeidstudier i honehus med kompaktbur og aviarier, ITF report No 29, Norges landbrukshogskole, Institut for Tekniske Fag, As, Norway. (In Norwegian).
- Malmberg, P. and Larsson, K., 1993. Acute exposure to swine dust causes bronchial hyperresponsiveness in healthy subjects. *European Respiratory Journal* 6: 400-404.
- Martens, W., Martinec, M., Zapirain, R., Stark, M., Hartung, E. and Palmgren, U., 2001. Reduction potential of microbial, odour and ammonia emissions from a pig facility by biofilters. *International Journal of Hygiene and Environmental Health* 203: 335-345.
- Melbostad, E. and Eduard, W., 2001. Organic dust-related respiratory and eye irritation in Norwegian farmers. *American Journal of Industrial Medicine* 39: 209-217.
- Melbostad, E., Wijnand, E. and Magnus, P., 1997. Chronic bronchitis in farmers. *Scandinavian Journal of Work Environment and Health* 23(4): 271-280.
- Nagaraja, K.V., 1983. Scanning electron microscope studies of adverse effects of ammonia on tracheal tissues of turkeys. *American Journal of Veterinary Research* 44: 1530-1536.
- Nagaraja, K.V., 1984. Effect of ammonia on the quantitative clearance of *E. coli*. *American Journal of Veterinary Research* 45: 392-395.
- Ni, J.Q., Vinckier, C., Coenegrachts, J. and Hendriks, J., 1999. Effect of manure on ammonia emission from a fattening pig house with partly slatted floor. *Livestock Production Science* 59: 25-31.
- Nicolai, R., Janni, K. and Schmidt, D., 2004. Frequently asked questions about biofilters. Department of Biosystems and Agricultural Engineering, University of Minnesota, Extension Program. St. Paul, MN, USA.
- Nilsson, C., 1982. Dammundersokningar i slaktssvinstallar [Dust investigations in pig houses]. Swedish University of Agricultural Sciences, Department of Farm Buildings, Lund, Sweden, Report 25, 93 pp.

### 13. Control of emissions from livestock buildings and the impact of aerial environment

- Nimmermark, S., Lund, V., Gustafsson, G. and Eduard, W., 2009. Ammonia, dust and bacteria in welfare-oriented systems for laying hens. *Annals of Agricultural and Environmental Medicine* 16: 103-113.
- Oldenburg, J., 1989. Geruchs- und Ammoniak-emissionen aus der Tierhaltung [Odour- and ammoniakemission from animal production]. Kuratorium für technik und Bauwesen in der Landwirtschaft, KTBL-Schrift 333, Darmstadt, Germany, 158 pp.
- Pedersen, S., 1993. Time-based variation in airborne dust in respect to animal activity. *Proceedings: Livestock Environment IV*. ASAE, St. Joseph, MI, USA, pp. 718-726.
- Rank, M., 1988. Untersuchungen zur Ammoniakverflüchtigung nach Gülleddüngung [Investigation about the ammonia volatilization from manure]. Dissertation. Institut für Bodenkunde, Pflanzenernährung und Phytopathologie, Technische Universität München, Germany, 108 pp.
- Reece, F.N. and Lott, D.B., 1954. The effect of ammonia and carbon dioxide during brooding on the performance of broiler chickens. *Poultry Science* 59: 1654-1661.
- Robertson, J.F., 1992. Dust and ammonia in pig buildings. *Farm Building Progress*, 110: 19-24.
- Robertson, J.F., 1993. Dust and ammonia in pig housing: the need to reduce maximum exposure limits. *Proceedings: Livestock Environment IV*, ASAE, St. Joseph, MI, USA, pp. 694-700.
- Robertson, J.F., Wilson, D. and Smith, W.J., 1990. Atrophic rhinitis: the influence of the aerial environment. *Animal Production* 50: 173-182.
- Schmidt, D., Janni, K. and Nicolai, R., 2004. Biofilter design information. *Biosystems and Agricultural Engineering Update*, BAEU-18. Department of Biosystems and Agricultural Engineering. University of Minnesota. St. Paul, MN, USA.
- Sheridan, B.A., Curran, T.P. and Dodd, V.A., 2002. Assessment of the influence of media particle size on the biofiltration of odorous exhaust ventilation air from a piggery facility. *Bioresource Technology* 84(2): 129-143.
- Sommer, S.G., Olesen, J.E. and Christensen, B.T., 1991. Effects of temperature, wind speed and air humidity on ammonia volatilization from surface applied cattle slurry. *Journal of Agricultural Science* 117: 91-100.
- Sommer, S.G., Zhang, G.Q., Bannink, A., Chadwick, D., Misselbrook, T., Harrison, R., Hutchings, N.J., Menzi, H., Monteny, G.J., Ni, J.Q., Oenema, O., Webb, J. and Donald, L.S., 2006. Algorithms determining ammonia emission from buildings housing cattle and pigs and from manure stores. *Advances in Agronomy* 89: 261-335.
- Svensson, L., 1993. Ammonia volatilization from land-spread manure – effects of factors relating to meteorology, soil/manure and application technique. Dissertation. Swedish University of Agricultural Sciences, Department of Agricultural Engineering, Uppsala, Sweden, 104 pp.
- Swedish Work Environmental Authority, 2005. Occupational exposure limit values and measures against air contaminants. Swedish Work Environmental Authority, Stockholm, Sweden.
- Takai, H. and Iversen, M., 1990. Arbejdsmiljø i svinstalde. (Working environment in pig houses). *Statens Jordbrugstekniske Forsøg*, Horsens, Denmark, Orientering No 69, 44 pp.
- Takai, H. and Pedersen, S., 1999. Design concept of oil sprayer for dust control in pig buildings. *Proceedings: international symposium on dust control in animal production facilities*, 30 May -2 June, 1999, Aarhus, Denmark, pp. 279-285.
- Takai, H., Nekomoto, K., Dahl, P., Okamoto, E., Morita, S. and Hoshiba., 2002. Ammonia contents and desorption from dust collected in livestock buildings. *Agricultural Engineering International: the CIGR Journal of Scientific Research and Development*, Manuscript BC 01 005. Vol. IV.

- Tielen, M.J.M., Preller, L., Van Gulick, P., Vogelzang, P.J.J. and Elbers, A.R.W., 1995. Health status of Dutch pig farmers and veterinarians in relation to the occupational exposure. Proceedings: 46<sup>th</sup> Annual Meeting of the European Association for Animal Production, (EAAP), 4-7 September, Prague, Czech Republic.
- Van 't Klooster, C.E., Roelofs, P.F.M.M. and Gijzen, P.A.M., 1993. Positioning air inlet and air outlet to reduce dust exposure in pig buildings. Proceedings: Livestock Environment IV, ASAE, St. Joseph, MI, USA, pp. 754-761.
- Von Essen, S. and Romberger, D., 2003. The respiratory inflammatory response to the swine confinement building environment: The adaptation to respiratory exposures in the chronically exposed worker. *Journal of Agricultural Safety and Health* 9(3): 185-196.
- Von Wachenfelt, E., 1993. Air contamination in poultry production systems, 4:th European Symposium on Poultry, Edinburgh, UK, September 18-24.
- Wathes, C.M., Demmers, T.G.M., Teer, N., White, R.P., Taylor, L.L., Bland, V., Jones, P., Armstrong, D., Gresham, A.C.J., Hartung, J., Chennells, D.J. and Done, S.H., 2004. Production responses of weaned pigs after chronic exposure to airborne dust and ammonia. *Animal Science* 78(1): 87-97.
- Whyte, R.T., 2002. Occupational exposure of poultry stockmen in current barn systems for egg production in the United Kingdom. *British Poultry Science* 43(3): 364-373.
- Zhang, Y., Tanaka, A., Dosman, J.A., Senthilselvan, A., Barber, E.M., Kirychuk, S.P., Holfeld, L.E. and Hurst, T.S., 1998. Acute respiratory responses of human subjects to air quality in a swine building. *Journal of Agricultural Engineering Research* 70(4): 367-373.

## 14. Controlling the concentrations of airborne pollutants in three different livestock facilities<sup>3</sup>

T. Banhazi

National Centre for Engineering in Agriculture (NCEA), University of Southern Queensland, West Street, Toowoomba, QLD 4530, Australia; [thomas.banhazi@usq.edu.au](mailto:thomas.banhazi@usq.edu.au)

### Abstract

The negative effects of high concentration of airborne pollutants on animal health, welfare and productivity are well documented. Reducing the concentration of airborne pollutants in livestock buildings is therefore an important task and could also help to reduce the occupational health and safety risk associated with farm work. The main objective of this research was to evaluate the effects of spraying a mixture of oil and water directly on the floors of livestock building or applying oil treatment to different bedding materials on the concentration of airborne pollutants inside three different livestock facilities. In addition, a number of other airborne pollutant reduction methods were trialled in a horse facility. Air quality parameters were recorded in: (1) a number of partially slatted, mechanically or naturally ventilated pig facilities; (2) a horse stable; and (3) two poultry buildings. Airborne pollutant concentrations were measured and compared between the treatment and control facilities. The concentrations of both inhalable and respirable airborne particles were significantly reduced in the experimental pig facilities. The results also demonstrated a significant reduction ( $P < 0.001$ ) in the concentrations of inhalable and respirable airborne particles in the horse boxes treated with oil-impregnated bedding material as well in the oil treated poultry building. This technique would enable livestock producers to improve the environmental quality in livestock buildings at a relatively low cost.

**Keywords:** poultry, pigs, horses, air quality, spraying, reduction, emission, ammonia, dust, airborne particles

### 14.1 Introduction

#### 14.1.1 Piggery buildings

Dust is one of the major airborne pollutants associated with intensive livestock production and determines the quality of the environment within livestock buildings (Banhazi *et al.*, 2009a,b). The negative effects of high concentration of bioaerosol on human and animal health, as well as on animal welfare and productivity are well documented (Donham, 1991; Donham and Leininger, 1984; Donham *et al.*, 1984). Suspended airborne particles can also absorb toxic and noxious gases as well as bacteria components and act as vectors for these pollutants (Donaldson, 1977). High concentrations of airborne particles may contain bacterial toxins and appears to enhance both the prevalence and severity of respiratory diseases in pigs (Lee *et al.*, 2005). Reducing the

<sup>3</sup> This article is based on a number of conference papers that were published in the Proceedings of the International Society of Animal Hygiene 2007 Conference with the permission of the editors.

concentration of airborne particles in piggery buildings is therefore an important component of good management and can improve production efficiency and reduce the potentially harmful effects of long term exposure to humans (Donham *et al.*, 1989). Australian data also suggests that an average enterprise of 200-400 sows on a single site would release significant amounts of dust, bacteria, ammonia and endotoxins into the surrounding environment via emissions from buildings (Banhazi *et al.*, 2008a). Emissions generally, but especially dust related emissions from pig farms are now very closely regulated in the EU and excessive emissions could result in reduced market access of individual piggery operators (Cambra-López *et al.*, 2010). Therefore, simple, low-cost and practical techniques, which will have the potential to deliver a significant reduction of dust, ammonia and other pollutant emissions cost effectively, need to be investigated, developed and evaluated (Banhazi *et al.*, 2011; Takai and Pedersen, 2000). Spraying the floor of pig sheds with a mixture of oil and water (Takai *et al.*, 1995) is a potentially beneficial technique.

#### **14.1.2 Horse stables**

Horses appear to be more sensitive to airborne particles than other species of livestock and high concentration of airborne pollutants in horse stables reportedly interfere with the health and athletic ability of these animals. Adequate air quality, including low airborne particle concentrations in stables is an important component of good horse husbandry (Blunden *et al.*, 1994; Carpenter, 1986; Woods *et al.*, 1993). Horses are sensitive to airborne particles and a strong association has been demonstrated between airborne pollution and respiratory diseases in horses (Christley *et al.*, 2000; Clarke and Madelin, 1987b). Poorly managed horse stables with high airborne particle concentrations may affect the animals' respiratory health as well as the health of stable workers (Gruys *et al.*, 1994). Horses in countries with colder climate are routinely stabled for a large part of the day so the maintenance of acceptable air quality becomes an important aspect of good stable management (Mathews and Arndt, 2003). In addition, horses are kept in buildings for extended periods over many years and thus the length of exposure to airborne pollutants is significantly greater than for food animals (Clarke and Madelin, 1987b; Vandenput *et al.*, 1998). Therefore, appropriate airborne particle reduction methods have to be an integral part of routine stable management (Clarke and Madelin, 1987b; Dunlea and Dodd, 1997).

#### **14.1.3 Poultry buildings**

The present economic climate of poultry production forces producers to focus on improving efficiency. One of the important factors in achieving improved efficiency is the provision of an optimal building environment (Aerts *et al.*, 2003). Optimal environment encompasses good air quality including gas, particles and microbial concentrations as well as controlled temperature, humidity and ventilation rates (Scott, 1984). An improvement in air quality within poultry buildings should enhance production efficiency and health of birds (Al Homidan *et al.*, 1998) as well as reduce Occupational Health and Safety (OH&S) related health problems in humans (Donham *et al.*, 1989; Whyte, 2002). The litter is a major source of particles in poultry houses and its characteristics would affect airborne particle concentrations (Banhazi *et al.*, 2008b). Therefore, the most likely factors, which can be controlled to achieve a reduction in the concentration of airborne particles in poultry buildings, are the quality and characteristics of the bedding material.

## 14. Controlling the concentrations of airborne pollutants

### 14.1.4 Study aims

The overall objective of this study was to evaluate the effects of oil spraying and oil impregnation primarily on the concentration of airborne particles inside livestock facilities, but the effects of the treatments on the concentration of other airborne pollutants were also investigated. In addition, a variety of airborne pollution abatement techniques were assessed in a horse facility. As a result of reduced internal concentration levels, marked reduction can also be achieved in pollutant emission, assuming the same level of ventilation. In turn, the environmental sustainability of the farming operation can be improved. So to facilitate the wider adoption of particle reduction techniques, a series of experiments have been conducted in South Australia to evaluate the effects of different management strategies aimed at reducing airborne particle and other airborne pollutant concentrations in different livestock buildings.

### 14.2 Material and methods

#### 14.2.1 Experimental design: piggery buildings

An automated oil spraying system was installed in a number of piggery buildings (Figure 14.1). General design concepts of oil spraying systems have been published previously (Banhazi, 2005; Lemay *et al.*, 1999; Takai and Pedersen, 1999), but a brief description of the system is given below.

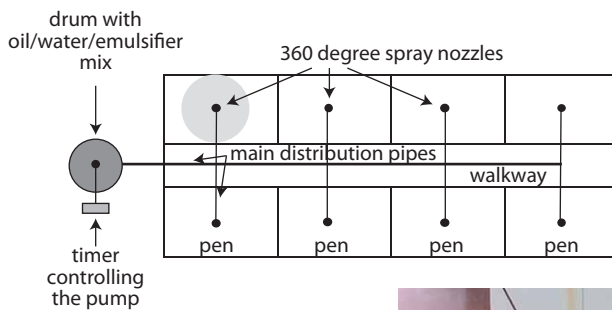

Figure 14.1. Basic design and assembled spray-system with the holding tank for the oil/water mixture.

The actual spray system was assembled simply and cheaply from commercially available components. Important components of the system were; mixing drum with delivery pump, main delivery pipes, secondary delivery pipes and spray heads. The main considerations when selecting spray heads were their ability to evenly distribute the mixture, area coverage, droplet size produced and pump pressure available. The spray system was positioned on the top of the pen walls by utilising a wire cable spanning between the pen walls. The main delivery pipes of the spray system were then attached to the wire cable using plastic 'cable-ties'.

Air quality parameters were recorded for 25 days in two partially-slatted, mechanically ventilated weaner rooms housing 89 pigs (approximate mean live weight 18 kg) and for 10 days in two partially-slatted, naturally ventilated grower rooms housing 91 pigs (approximate mean live weight 42 kg). The floor of one of the rooms (experimental facility) was sprayed daily with a canola oil, water and surfactant mixture at a 4:5:1 ratio and at the rate of 3 g/pig (6.3 g/m<sup>2</sup>), using an automatic spraying system. The other room was not treated and served as a control facility. Air quality parameters were measured throughout the trials.

#### 14.2.2 Experimental design: horse buildings

In order to develop best practice management procedures, the effects of three different bedding material treatments on the resultant air quality were assessed during an experiment and compared to 'standard' sawdust bedding (control). The effects of: (1) sawdust impregnated with canola oil at the inclusion rate of approximately 7% (weight/weight); (2) straw bedding; and (3) 'horse-nappies' (that prevents the bedding material to be contaminated with faecal material) on the concentration of airborne particles inside four horse stables were studied, using 4×4 Latin Square experimental design over four weeks. The advantage of the Latin Square design is that it effectively controls for different sources of variation that may possibly increase experimental errors (Chen and Chen, 1999; Demidenko and Stukel, 2002; Tukey, 1997). The boxes were cleaned between experiments to avoid any carry over effects from previous treatments. Each box received the treatment for a week and then the treatments were re-allocated randomly (Table 14.1).

Table 14.1. Experimental design for the horse trial.<sup>1</sup>

Week	Horse box A	Horse box B	Horse box C	Horse box D
1	straw treatment	control	oil treatment	nappy treatment
2	oil treatment	nappy treatment	straw treatment	control
3	control	straw treatment	nappy treatment	oil treatment
4	nappy treatment	oil treatment	control	straw treatment

<sup>1</sup> Straw treatment: straw bedding, without nappy and without oil spraying; oil treatment: saw-dust bedding, without nappy and with oil spraying; control: saw-dust bedding, without nappy and without oil spraying; nappy treatment: saw-dust bedding, with nappy and without oil spraying.



### 14.2.3 Experimental design: poultry buildings

A classical comparative experiment was conducted at a South Australian poultry farm. Two identical and environmentally controlled broiler buildings (approximate size of 370 m<sup>2</sup>) on the same poultry farm were selected for the experiment and chopped straw was used as litter material in both buildings. The bedding material in one of the buildings was treated with the oil/water mixture, while the other building stocked at the same rate was used as control building. Male meat birds were placed in the buildings at the same time and were stocked at 15.9 birds/m<sup>2</sup>. The light program was a continuous ten hours dark period from 5 p.m. to 3 a.m. The incorporation rate of oil was based on the results of the preliminary shaker-box trial (Banhazi *et al.*, 2002). The quantity of oil used represented approximately 7.5% of the weight of the bedding material. The treatment was applied after the chopped straw was spread inside the buildings and before the birds were introduced. Canola oil, water and surfactant (emulsifier) were mixed in a drum at the ratio of 8:4:1. The water was incorporated at a minimum rate to prevent excessive wetting of the litter, however some water was necessary to facilitate spraying of the mixture. The high viscosity of the oil made it difficult to use any low-pressure spraying instrumentation for the delivery of the oil treatment. The mix was poured into a backpack-spraying unit containing 16 litres of the mixture and sprayed directly onto the litter that was then raked to homogeneously spread the mix.

### 14.2.4 Measurements

#### *Measurement locations*

During the studies in the piggery buildings, the instruments were usually placed as close to pig level as practically possible without allowing the pigs to interfere with the measurement instrumentation. In most buildings, the sensors were attached by wire cable to the ceiling or a beam and were lowered to pig level (approximately 1.1-1.3 m) above the selected pens. During the trial in the horse facility, air quality and environmental parameters were recorded in the four naturally ventilated horse boxes housing one horse each. The equipment was protected by a small wire cage that enabled the research team to place the monitoring instrumentation at the head level of the horses. During the study in the poultry building, again wire cages were positioned in the middle of both poultry buildings to protect the measuring devices, which were deployed within these cages in both the experimental and control buildings. This arrangement ensured that the concentrations of airborne pollutants and environmental parameters were measured at animal level.

#### *Temperature and humidity*

Self-contained, battery-operated data-loggers with built-in sensors (Tinytalk-2, Hastings Dataloggers Pty. Ltd., Port Macquarie, Australia) were used to measure temperature and relative humidity both inside and outside of all buildings. The range of the temperature sensors was -45 °C to +75 °C, with a documented accuracy of  $\pm 0.5$  °C at 25 °C. The humidity sensors had a range of 0% to 100%, with a documented accuracy of  $\pm 3\%$  at 25 °C.



### *Airborne particles*

Airborne particles concentration inside the buildings was measured utilising the standard gravimetric method, as described previously (Banhazi *et al.*, 2008c). Total inhalable and respirable particle concentrations were measured using GilAir air pumps (Gilian Instrument Corp., West Caldwell, NJ, USA) connected to cyclone filter heads (for respirable particles) and Seven Hole Sampler (SHS) filter heads (for inhalable dust) (Casella, Ltd., Kempston, UK) and operated over a 6 or 8-hour period at 1.9 and 2.0 l/min flow rate, respectively. After sampling, the filter heads were taken back to the laboratory and weighed to the nearest 0.001 mg using certified microbalances and then the inhalable and respirable dust levels were calculated. The filters were conditioned appropriately by being kept in the laboratory for approximately 24 h before and after deployment. Continuous dust monitoring equipment (OSIRIS light-scattering instrument, Turnkey Instruments, Ltd., Northwich, UK) was used in some buildings to collect dust distribution information (Figure 14.2). The OSIRIS instruments were supplied with the factory calibration and were recalibrated annually by the supplier.

### *Gas measurements*

Ammonia NH<sub>3</sub> and carbon dioxide CO<sub>2</sub> were monitored continuously using a multi-gas monitoring machine in each building, as described previously (Banhazi *et al.*, 2008c). Electrochemical (Bionics TX-FM/FN, Bionics Instrument Co., Tokyo, Japan) and infrared sensors (GMM12, Vaisala Oy, Helsinki, Finland) were used to detect the concentrations of NH<sub>3</sub> and CO<sub>2</sub>, respectively. The gas sensors were enclosed in a shock-resistant electrical box and an air delivery system was used to deliver air samples from the sampling points within and outside the buildings to the actual gas monitoring heads. Air was drawn at a nominal rate of 0.5-0.8 l/min from the sampling points and after each sampling point had been monitored for 15 min, the system was purged for 15 min with fresh air drawn from outside the buildings. The equipment was calibrated (using standard 50 mg/m<sup>3</sup> NH<sub>3</sub> and 2,500 mg/m<sup>3</sup> CO<sub>2</sub> calibration gases, Calgaz,

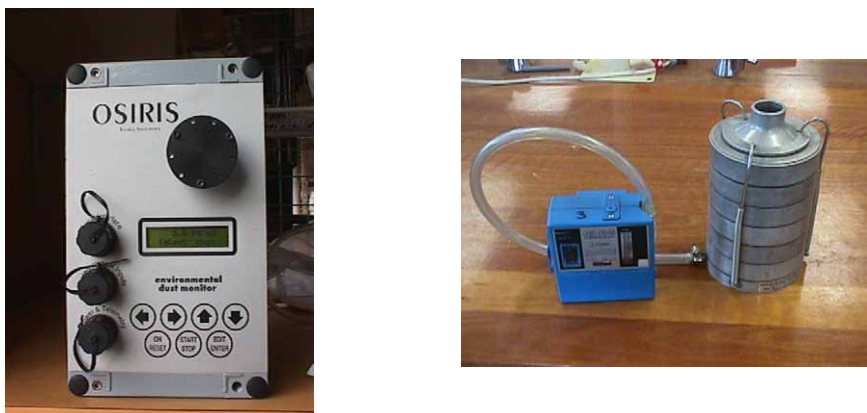

Figure 14.2. Measurement equipment used during the study included the OSIRIS particle monitoring equipment (left) and Anderson bacteria sampler (right).

## 14. Controlling the concentrations of airborne pollutants

Air Liquide Australia Ltd., Melbourne, Australia) as required. A filter was attached to the end of each intake tube to prevent the deposition of particles in the sampling line.

### *Bacteria measurements*

Total viable airborne bacteria were measured using an Anderson viable six-stage bacterial impactor (Clarke and Madelin, 1987a) filled with horse blood agar plates (HBA, Medvet Science Pty. Ltd., Stepney, Australia). The airspace was sampled for five minutes at a flow rate of 1.9 l/min (Figure 14.2). The bacteria plates were incubated for 48 h at 37 °C and the number of colony forming units (cfu) were counted manually to express the concentration of airborne microorganisms as cfu/m<sup>3</sup>.

### **14.2.5 Statistical methods**

A General Linear Model (GLM) was developed to determine the effects of the oil treatment on airborne pollutant concentrations, considering experimental effects and covariates such as internal humidity, air temperature, bedding temperature, CO<sub>2</sub> concentrations and age of birds/animals (SAS, 1989; StatSoft, 2001). Data collected previously in piggery buildings were reassessed, truncated and also reanalysed using GLM techniques to provide more reliable results (Banhazi, 2007).

## **14.3 Results and discussion**

### **14.3.1 Piggery buildings**

The concentration of both inhalable and respirable airborne particles as well as airborne bacteria (only in weaner building) was significantly reduced in the experiment facilities (Table 14.2 and Figure 14.3). Only the experimental effect proved to be significant; no other effects were identified by the statistical analysis to be significantly influencing airborne pollutant levels in the control and experimental rooms.

*Table 14.2. Concentrations of respirable and inhalable airborne particles, viable bacteria and ammonia for the control and treatment rooms.*

Treatment	Respirable particles (mg/m <sup>3</sup> )	Inhalable particles (mg/m <sup>3</sup> )	Total bacteria (×1000 cfu/m <sup>3</sup> )	Ammonia (mg/m <sup>3</sup> )
Weaner (control)	0.212 <sup>a</sup>	4.118 <sup>a</sup>	71 <sup>a</sup>	10.1 <sup>a</sup>
Weaner (treatment)	0.138 <sup>b</sup>	2.022 <sup>b</sup>	32 <sup>b</sup>	9.0 <sup>a</sup>
Grower (control)	0.116 <sup>a</sup>	1.451 <sup>a</sup>	68 <sup>a</sup>	8.1 <sup>a</sup>
Grower (treatment)	0.101 <sup>a</sup>	0.682 <sup>b</sup>	109 <sup>b</sup>	9.2 <sup>a</sup>

<sup>a,b</sup> Values in the same column and within the same age group (i.e. weaner vs. grower pigs) with different superscripts differ significantly ( $P < 0.05$ ).

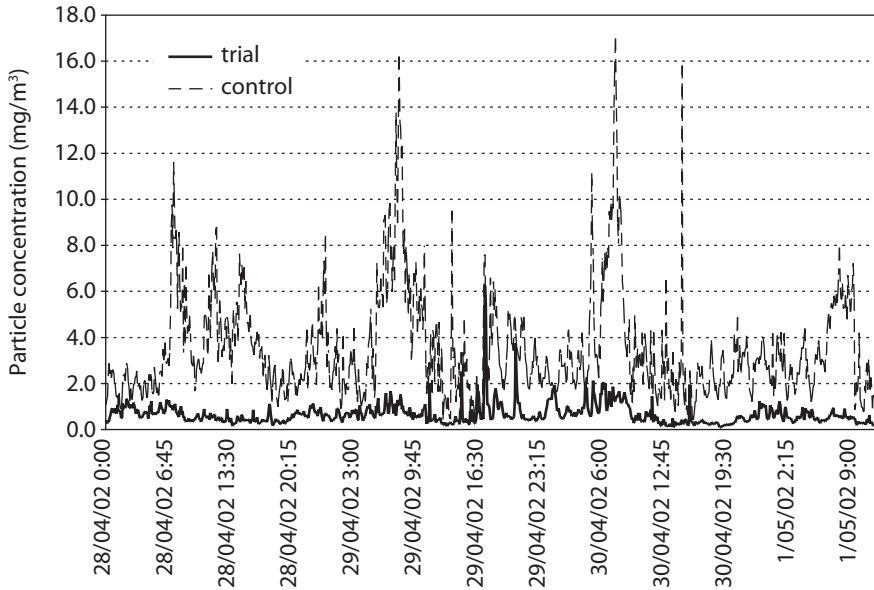

Figure 14.3. Airborne particle reduction achieved (Osiris measurements) at a piggery during 4 days of the commercial trials in the weaner rooms ( $\text{mg}/\text{m}^3$ ).

Measurement conducted using the OSIRIS optical particle counter demonstrated the visible dust reduction achieved in the experimental facilities (Figure 14.3). Although the results provided by the OSIRIS equipment are generally not considered as precise as gravimetric measurements by some; these readings demonstrated the relative dust reduction achieved when dust concentrations in the control and experimental facilities were compared in real time.

The experiment demonstrated a significant reduction in the concentrations of both inhalable and respirable airborne particles in the airspace following the direct spraying of an oil and water mixture onto the floor. This study confirmed previously published data (Takai *et al.*, 1995) and the technique used in the experiment could be used by producers to effectively reduce dust levels in piggery building. However, further studies are needed to determine the long-term effects of frequent oil spraying on subsequent surface hygiene of pen floors. Overall, the technique is a safe and efficient dust reduction method and could be promoted to producers experiencing dust problems in their facilities. This study demonstrated that oil spraying have the potential of significantly reducing pollutant concentrations cost effectively (Takai *et al.*, 1995). In fact, compared to other available dust reduction methods, oil spraying is expected to be one of the most efficient dust reduction strategies currently available to pig producers (Pedersen *et al.*, 2001).

### 14.3.2 Horse building

Temperature and the concentration of carbon dioxide did not vary significantly throughout the experiment but there was a statistically significant ( $P=0.006$ ) reduction in the concentration of

## 14. Controlling the concentrations of airborne pollutants

inhalable particles (Table 14.3). On average, inhalable particle concentrations were the highest for the 'straw' followed by the 'control' treatments. The 'nappy' and 'oil' treatments gave the lowest concentrations of inhalable particles and the difference between these two treatments was not significant.

Respirable particle concentrations were also positively affected by the treatment, but only in interaction with the 'day' effects (Figure 14.4).

The interaction was mainly influenced by the readings from the first day of the weekly measurements. On the first day of the week (Monday) there was considerable variation between the treatments with the 'straw' treatment having the highest readings of respirable dust (Figure 14.4). This variability or difference between treatments decreased over the subsequent measurement days. However, as an overall trend it can be seen from the graph that the highest concentrations of respirable particles were recorded for the 'straw' and 'control' treatments compared with 'nappy'

Table 14.3. Temperature and the concentrations of inhalable airborne particles and carbon dioxide for the control and treatment boxes.

Treatment	Temperature (°C)	Inhalable dust (mg/m <sup>3</sup> )	Carbon dioxide (mg/m <sup>3</sup> )
Control (saw dust)	22.2 <sup>a</sup>	0.397 <sup>a</sup>	499 <sup>a</sup>
Straw bedding	22.5 <sup>a</sup>	0.606 <sup>b</sup>	488 <sup>a</sup>
Horse-nappy	22.2 <sup>a</sup>	0.287 <sup>c</sup>	508 <sup>a</sup>
Oil-impregnated saw dust	22.3 <sup>a</sup>	0.298 <sup>c</sup>	504 <sup>a</sup>

<sup>a,b</sup> Values in the same column with different superscripts differ significantly ( $P < 0.05$ ).

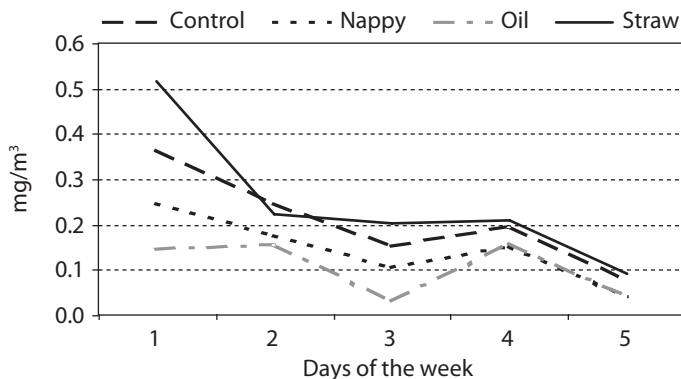

Figure 14.4. The effects of treatment and day interaction on respirable particle concentrations (mg/m<sup>3</sup>).

and 'oil' treatments. The 'oil' treatment gave the lowest concentrations of respirable particles, compared to all other treatments (Table 14.3).

Differences between relative humidity readings were also highly significant ( $P<0.001$ ), indicating that adjusting for this co-variate within the analysis was important (Figure 14.5). Treatment and Day effects significantly interacted ( $P=0.041$ ) for this variable (Figure 14.5). Relative humidity on average increased over the 5-day measurement period for 'oil' and 'control' treatments, but decreased for the 'nappy' treatment over the experimental days. This is likely to be due to the horse nappy preventing contamination of the bedding material with faecal matter.

These results demonstrate a significant reduction in the concentrations of inhalable and respirable airborne particles in horse boxes using either oil-impregnated bedding material or horse nappies can be achieved. These techniques would enable horse keepers to improve the environmental quality of horse stables at a relatively low cost (Banhazi and Woodward, 2007). However, further studies are needed to determine the best method of incorporating oil into the bedding material, the minimum concentration of oil necessary and the effects of oily bedding material on the health and wellbeing of the animals.

### 14.3.3 Poultry buildings

Figure 14.6 show the mean concentrations of inhalable and respirable airborne particles in the treatment and control rooms. The oil treatment significantly ( $P<0.001$ ) reduced the concentrations of both inhalable and respirable particles in the treatment room, which is consistent with the effect of oil treatment demonstrated in previous studies (Banhazi *et al.*, 2011; Feddes *et al.*, 1995).

The age of birds also had a significant effect on inhalable particles concentration ( $P<0.05$ ) but not on respirable particles. The inhalable particles concentration increased with the age of birds, which agreed with previous studies (Hinz and Linke, 1998; Madelin and Wathes, 1989). The internal temperature significantly ( $P<0.05$ ) affected the respirable particles concentration although it was not statistically significant for the inhalable particles concentration.

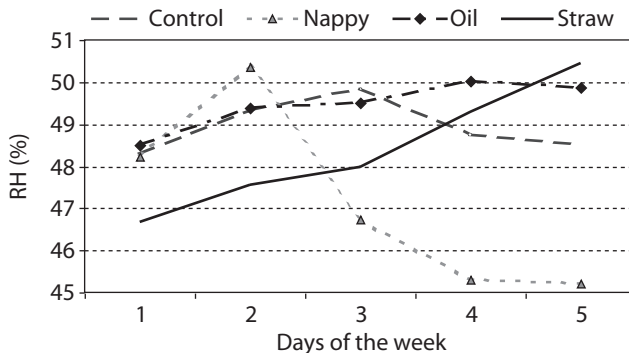

Figure 14.5. The effects of treatment and day interaction on relative humidity (RH, %).

## 14. Controlling the concentrations of airborne pollutants

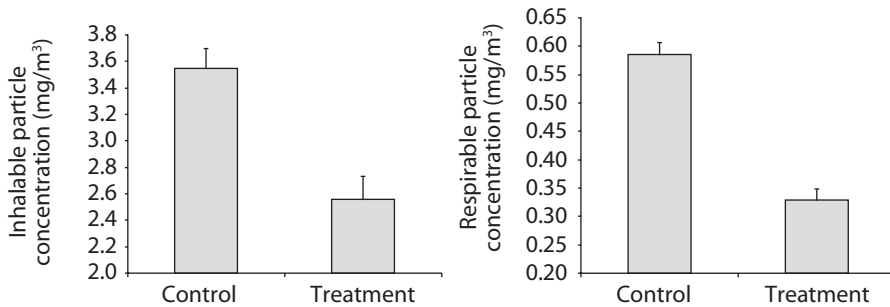

Figure 14.6. The LS mean ( $\pm$  standard error) inhalable and respirable particle concentrations in control and trial buildings.

A significant reduction in ammonia concentration ( $P < 0.001$ ) was also demonstrated in the treatment room. Figure 14.7 shows the mean ammonia concentration in control and trial rooms. A reduction of ammonia concentrations with the same type of oil treatment was reported in piggery buildings (Jacobson *et al.*, 1998). However, the effect of the oil treatment on ammonia was not demonstrated in previous studies in poultry buildings (Feddes *et al.*, 1995). One possible explanation for the positive effect demonstrated in this study is that the oil treatment might interfere with the bacterial flora in bedding responsible for ammonia generation from nitrogenous compounds, thus decreasing the ability of bacteria to generate ammonia (Banhazi *et al.*, 2007). Despite the fact that the reduction of ammonia concentrations has not been fully explained, this finding was an important result because high ammonia levels are not advantageous for poultry production.

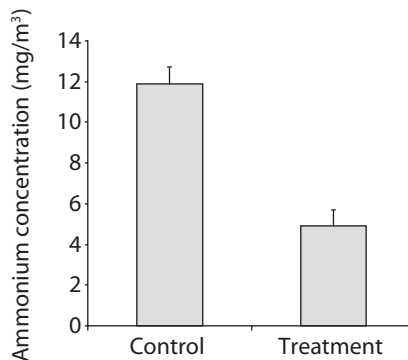

Figure 14.7. LS Mean ( $\pm$  standard error) ammonia concentrations in control and treatment buildings.

## **14.4 Conclusions**

Overall, these studies have demonstrated that airborne particle (and potentially ammonia) concentrations can be significantly reduced in livestock buildings by either impregnating the bedding material with a relatively small amount of oil, or by directly spraying oil on the floor of the farm buildings.

However, oil application has to be made more practical via associated engineering developments, as the experimentally used manual spraying and raking (applied in the poultry and horse facilities) is not practical under commercial conditions. In the future the oil should be directly incorporated into the bedding material before spreading. The spreading of the bedding material is normally associated with high airborne particle concentrations and the reduction of airborne particles during that time is most likely to have beneficial effect on worker safety and respiratory health.

In addition, the reduction of particle levels indoors will also reduce particle emissions, assuming constant ventilation rates. The future adoption of particle reduction strategies in the intensive livestock industries is important, due to the increasing environmental and occupational health and safety requirements. The oil application methods, utilised during these experiments, appeared to be useful and practical. However, further experiments are needed to assess the potentially beneficial effects of particle reduction on production efficiency that will further encourage producers to utilise these techniques.

## **Acknowledgements**

The author wishes to acknowledge the financial support of (1) the Australian Pork Limited (APL), (2) the University of Adelaide, Department of Animal Science and (3) the Rural Industries Research and Development Corporation (RIRDC). In addition the author wishes to recognise the professional support of Dr C. Cargill (South Australian Research and Development Institute, SARDI), Dr V. Kite (RIRDC), Dr R. Woodward (University of Adelaide), Dr J. Seedorf (Osnabrück University of Applied Sciences), M. Laffrique (Ecole Nationale Supérieure Agronomique de Rennes), Prof. J. Hartung, Hannover University, Germany, and the technical support of Mr K. Hillyard and Mr J. Wegiel of SARDI.

## **References**

- Aerts, J.-M., Wathes, C.M. and Berckmans, D., 2003. Dynamic data-based modelling of heat production and growth of broiler chickens: development of an integrated management system. *Biosystems Engineering* 84: 257-266.
- Al Homidan, A., Robertson, J.F. and Petchey, A.M., 1998. Effect of environmental factors on ammonia and dust production and broiler performance. *British Poultry Science* 39: S10.
- Banhazi, T., 2005. Oil spraying systems for piggeries to control dust. In: Fahy, T. (ed.) *Proceedings of AAPV Conference*, 15-19 May, 2005, Gold Coast, QLD, Australia, pp. 76-80.
- Banhazi, T., 2007. Improving air quality in piggery buildings. In: Aland, A. (ed.) *XIII International Congress on Animal Hygiene*. Estonian University of Life Sciences, Estonia, pp. 237-241.

## 14. Controlling the concentrations of airborne pollutants

- Banhazi, T., Laffrique, M. and Seedorf, J., 2007. Controlling the concentrations of airborne pollutants in poultry buildings. In: Aland, A. (ed.) XIII International Congress on Animal Hygiene. Estonian University of Life Sciences, Estonia, pp. 302-307.
- Banhazi, T., Murphy, T. and Cargill, C., 2002. Evaluating oil inclusion rates for bedding materials. In: Revell, D.K. and Taplin, D. (eds.) Animal production in Australia. ASAP, QLD, Australia, pp. 378.
- Banhazi, T. and Woodward, R., 2007. Reducing the concentration of airborne particles in horse stables. In: Aland, A. (ed.), XIII International Congress on Animal Hygiene, June 2007, Tartu, Estonia. Estonian University of Life Sciences, pp. 483-487.
- Banhazi, T.M., Currie, E., Quartararo, M. and Aarnink, A.J.A., 2009a. Controlling the concentrations of airborne pollutants in broiler buildings. In: Aland, A. and Madec, F. (eds.) Sustainable animal production: The challenges and potential developments for professional farming. Wageningen Academic Publishers, Wageningen, the Netherlands, pp. 347-364.
- Banhazi, T.M., Currie, E., Reed, S., Lee, I.-B. and Aarnink, A.J.A., 2009b. Controlling the concentrations of airborne pollutants in piggery buildings. In: Aland, A. and Madec, F. (eds.) Sustainable animal production: the challenges and potential developments for professional farming. Wageningen Academic Publishers, Wageningen, the Netherlands, pp. 285-311.
- Banhazi, T.M., Rutley, D.L. and Pitchford, W.S., 2008a. Identification of risk factors for sub-optimal housing conditions in Australian piggeries – Part IV: Emission factors and study recommendations. *Journal of Agricultural Safety and Health* 14: 53-69.
- Banhazi, T.M., Saunders, C., Nieuwe, N., Lu, V. and Banhazi, A., 2011. Oil spraying as a air quality improvement technique in livestock buildings: development and utilisation of a testing device. *Australian Journal of Multi-disciplinary Engineering* 8: 169-180.
- Banhazi, T.M., Seedorf, J., Laffrique, M. and Rutley, D.L., 2008b. Identification of the risk factors for high airborne particle concentrations in broiler buildings using statistical modelling. *Biosystems Engineering* 101: 100-110.
- Banhazi, T.M., Seedorf, J., Rutley, D.L. and Pitchford, W.S., 2008c. Identification of risk factors for sub-optimal housing conditions in Australian piggeries – Part II: Airborne pollutants. *Journal of Agricultural Safety and Health* 14: 21-39.
- Blunden, A.S., Hannant, D., Livesay, G. and Mumford, J.A., 1994. Susceptibility of ponies to infection with *Streptococcus pneumoniae* (capsular type 3). *Equine Veterinary Journal* 26: 22-28.
- Cambra-López, M., Aarnink, A.J.A., Zhao, Y., Calvet, S. and Torres, A.G., 2010. Airborne particulate matter from livestock production systems: a review of an air pollution problem. *Environmental Pollution* 158: 1-17.
- Carpenter, G.A., 1986. Dust in livestock buildings – review of some aspects. *Journal of Agricultural Engineering Research* 33: 227-241.
- Chen, Y.-H. and Chen, H., 1999. Incomplete covariates data in generalized linear models. *Journal of Statistical Planning and Inference* 79: 247-258.
- Christley, R.M., Rose, R.J., Hodgson, D.R., Reid, S.W.J., Evans, S., Bailey, C. and Hodgson, J.L., 2000. Attitudes of Australian veterinarians about the cause and treatment of lower-respiratory-tract disease in racehorses. *Preventive Veterinary Medicine* 46: 149-159.
- Clarke, A.F. and Madelin, T., 1987a. Technique for assessing respiratory health hazards from hay and other source materials. *Equine Veterinary Journal* 19: 442-447.
- Clarke, A.F. and Madelin, T.M., 1987b. The relationship of air hygiene in stables to lower airway disease and pharyngeal lymphoid hyperplasia in two groups of Thoroughbred horses. *Equine Veterinary Journal* 19: 524-530.



## T. Banhazi

- Demidenko, E. and Stukel, T.A., 2002. Efficient estimation of general linear mixed effects models. *Journal of Statistical Planning and Inference* 104: 197-219.
- Donaldson, A.I., 1977. Factors influencing the dispersal, survival and deposition of airborne pathogens of farm animals. *Veterinary Bulletin* 48: 83-94.
- Donham, K.J., 1991. Association of environmental air contaminants with disease and productivity in swine. *American Journal of Veterinary Research* 52: 1723-1730.
- Donham, K.J., Haglund, P., Peterson, Y., Rylander, R. and Belin, L., 1989. Environmental and health studies of farm workers in Swedish swine confinement buildings. *British Journal of Industrial Medicine* 46: 31-37.
- Donham, K.J. and Leininger, J.R., 1984. Animal studies of potential chronic lung disease of workers in swine confinement buildings. *American Journal of Veterinary Research* 45: 926-931.
- Donham, K.J., Zavala, D.C. and Merchant, J.A., 1984. Respiratory symptoms and lung function among workers in swine confinement buildings: a cross-sectional epidemiological study. *Archives of Environmental Health* 39: 96-101.
- Dunlea, A.P. and Dodd, V.A., 1997. Control of respirable dust in horse stables. In: Bottcher, R.W. and Hoff, S.J. (eds.) *Livestock environment V – 5<sup>th</sup> International Symposium*, 29-31 May 1997, Bloomington, MN, USA. American Society of American Engineers, pp. 536-546.
- Feddes, J.J.R., Taschuk, K., Robinson, F.E. and Riddell, C., 1995. Effect of litter oiling and ventilation rate on air quality, health and performance of turkeys. *Canadian Agricultural Engineering* 37: 57-62.
- Gruys, E., Obwolo, M.J. and Toussaint, M.J.M., 1994. Diagnostic significance of the major acute phase proteins in veterinary clinical chemistry: a review. *Veterinary Bulletin* 64: 1009-1018.
- Hinz, T. and Linke, S., 1998. A comprehensive experimental study of aerial pollutants in and emissions from livestock buildings. Part 2: results. *Journal of Agricultural Engineering Research* 70: 119-129.
- Jacobson, L.D., Hetchler, B., Janni, K.A. and Johnston, L.J., 1998. Odor and gas reduction from sprinkling soybean oil in a pig nursery. *ASAE Annual International Meeting*, 12-16 July 1998, Orlando, FL, USA, pp. 1-9.
- Lee, C., Giles, L.R., Bryden, W.L., Downing, J.L., Owens, P.C., Kirby, A.C. and Wynn, P.C., 2005. Performance and endocrine responses of group housed weaner pigs exposed to the air quality of a commercial environment. *Livestock Production Science* 93: 255-262.
- Lemay, S.P., Barber, E.M., Bantle, M. and Marcotte, D., 1999. Development of a sprinkling system using undiluted canola oil for dust control in pig buildings. In: Pedersen, S. (ed.), *Dust control in animal production facilities*. Danish Institute of Agricultural Science, Tjele, Denmark, pp. 215-222.
- Madelin, T.A. and Wathes, C.M., 1989. Air hygiene in a broiler house: comparison of deep litter with raised netting floors. *British Poultry Science* 30: 23-37.
- Mathews, E.H. and Arndt, D.C., 2003. Validation of models to predict the thermal and ventilation performance of horse stables. *Building and Environment* 38: 237-246.
- Pedersen, S., Nonnenmann, M., Rautiainen, R., Demmers, T.G.M., Banhazi, T. and Lyngbye, M., 2001. Dust in pig buildings. *Journal of Agricultural Safety and Health* 6: 261-274.
- SAS, 1989. *SAS/STAT® User's Guide, Version 6, Fourth Edition, Volume 2*. SAS Institute Cary, NC, USA.
- Scott, N.R., 1984. Livestock buildings and equipment: a review. *Journal of Agricultural Engineering Research* 29: 93-114.
- StatSoft, I., 2001. *STATISTICA*. StatSoft, Inc., Tulsa, OK, USA.
- Takai, H., Moller, F., Iversen, M., Jorsal, S.E. and Bille-Hansen, V., 1995. Dust control in pig houses by spraying rapeseed oil. *Transactions of the ASAE* 38: 1513-1518.

## 14. Controlling the concentrations of airborne pollutants

- Takai, H. and Pedersen, S., 1999. Design concept of oil sprayer for dust control in pig buildings. In: Pedersen, S. (ed.) *Dust control in animal production facilities*. Danish Institute of Agricultural Science, Tjele, Denmark, pp. 279-286.
- Takai, H. and Pedersen, S., 2000. A comparison study of different dust control methods in pig buildings. *Applied Engineering in Agriculture* 16: 269-277.
- Tukey, J., 1997. More honest foundations for data analysis. *Journal of Statistical Planning and Inference* 57: 21-28.
- Vandenput, S., Duvivier, D.H., Votion, D., Art, T. and Lekeux, P., 1998. Environmental control to maintain stabled COPD horses in clinical remission: effects of pulmonary function. *Equine Veterinary Journal* 30: 93-96.
- Whyte, R.T., 2002. Occupational exposure of poultry stockmen in current barn systems for egg production in the United Kingdom. *British Poultry Science* 43: 364-373.
- Woods, P., Robinson, N., Swanson, N., Reed, C., Broadstone, R. and Derksen, F., 1993. Airborne dust and aeroallergen concentration in a horse stable under two different management systems. *Equine Veterinary Journal* 25: 208-213.



# 15. Environmental and management effects associated with improved production efficiency in a respiratory disease free pig herd in Australia

T. Banhazi

National Centre for Engineering in Agriculture (NCEA), University of Southern Queensland, West Street, Toowoomba, QLD 4530, Australia; [thomas.banhazi@usq.edu.au](mailto:thomas.banhazi@usq.edu.au)

## Abstract

The combined effects of a number of housing related parameters were evaluated in relation to the production efficiency of pigs under commercial farm conditions. These parameters included, air temperature, stocking rate, stocking density and the concentrations of different airborne pollutants. The commercial piggery buildings were divided into two separate compartments containing control and experimental groups of animals. The compartments containing the experimental groups were managed in order to reduce the airborne pollution load on the animals, while the other sections were managed according to normal farm procedures (control groups). The growth rate and environmental variables of both groups were monitored and compared. The statistical analysis (using general linear models) identified key factors contributing to improved production efficiency, including ammonia concentrations in the compartments, the quantity and size of airborne particles and stocking density. This efficiency improvement was achieved without the opportunity to see any perceivable change in clinical health of the animals. Thus improving housing conditions on farms may improve profitability even in cases where livestock are not affected by well-defined infectious diseases.

**Keywords:** pig houses, environmental quality, dust, bacteria, ammonia, stocking rate, performance

## 15.1 Introduction

The major airborne pollutants that farm animals are exposed to in livestock buildings (Banhazi *et al.*, 2008c, 2009; Groot Koerkamp *et al.*, 1998; Seedorf *et al.*, 1998; Takai *et al.*, 1998) have the potential to significantly reduce the animals' production efficiency, health and welfare (Done *et al.*, 2005; Kovacs *et al.*, 1967; Lee *et al.*, 2005; Wathes *et al.*, 2004). Airborne pollutants that are commonly found in the airspace of commercial piggery buildings include ammonia (NH<sub>3</sub>), airborne bacteria (total airborne bacteria, gram positive and fungal species), inhalable and respirable particles. A mixture of these bioactive materials, known as bio-aerosol (dust particles, clumps of bacteria, noxious gases and toxins), can be inhaled into the lungs of the pigs. Subsequently, these pollutants can attack the animals' immune systems, triggering an inflammatory reaction, and a reduced resistance to respiratory infection (Urbain *et al.*, 1998). Feed intake may also be reduced, resulting in reduced growth rates (Lee *et al.*, 2005).

In addition to the potentially negative effects of airborne pollutants on the health and welfare of animals; airborne pollutants can also increase the occupational health and safety risks for

farm workers (Banhazi *et al.*, 2009). Compared with non-agricultural workers, the occurrence of symptoms related to respiratory problems (including a decline in lung function) increase when workers are exposed to the airborne pollutants found in piggery buildings (Donham, 2000; Dutkiewicz, 1997; Von Essen and Donham, 1999; Zejda *et al.*, 1994). The synergic effects of exposure to airborne pollutants may also increase the number of health problems experienced by humans and livestock (Donham *et al.*, 1977). Additionally, airborne pollutant emissions from livestock buildings could damage the surrounding environment (Banhazi *et al.*, 2008a). For example, in Australia particle emissions have impacted receptors up to 2000 m away from average-sized piggery buildings (Banhazi *et al.*, 2007).

Commonly, Age Segregated Rearing (ASR) is a method adopted in pig production systems to minimise the transmission of respiratory diseases between successive batches of pigs and thus to reduce the impact of these diseases on pigs. However, due to the fact that this experiment was conducted in a high health status herd, in this specific study health improvement of pigs was not a study objective. In addition, ASR facilitates the improvement of air and surface hygiene of piggery buildings (Cargill *et al.*, 1998). Under this regime pigs are housed in groups, with an age spread of less than two weeks, and facilities are managed on an all in/all out (AIAO) basis. This management method allows for a thorough cleaning to be implemented between batches of pigs. It has been hypothesised that the growth rate of pigs will increase by improving the quality of air and the general environment within their housing systems (Cargill and Banhazi, 1997). The cleaning regime adopted in an AIAO system may facilitate this improvement.

Therefore, the aim of this study was to improve environmental conditions within experimental piggery buildings situated on a respiratory-disease-free farm and to determine the effect of these improvements on the growth rate of pigs. To facilitate this experiment, the growth rate (average daily gain, ADG) and air quality (AQ) parameters were monitored in piggery buildings with (AIAO) and without improved management system (continuous flow, CF).

## **15.2 Materials and methods**

It was expected that implementing ASR would generally result in health improvement, in addition to production efficiency improvements. The respiratory-disease-free status of the study herd was essential so that the benefits of AQ improvement could be demonstrated effectively, as respiratory-health improvements would not be a contributing factor during analysis.

### **15.2.1 Experimental farm**

A farrow-to-finish farm with 600 sows, located in South Australia, was used as an experimental site. This farm had been free of *Mycoplasma hyopneumoniae* and *Actinobacillus pleuropneumoniae* for 10 years prior this experiment.

### **15.2.2 Experimental buildings**

The experimental facilities (a second-stage weaner and a grower building) used in this study were naturally ventilated, with controlled-shutters on both sides and the buildings had partially slatted

## 15. Environmental and management effects associated with improved production efficiency

floors (approximately 30%). Pelleted feed was fed *'ad lib'* from multi-space feeders within these buildings. Approximately 20 pigs were housed per pen without the provision of any bedding materials and the liquid slurry was flushed to outside manure lagoons, weekly. Approximately 200 pigs were housed in the AIAO sections, which were created at the end of each building using tarpaulin material (Cavacon 5000Q, Tolai marketing, Adelaide, Australia). Approximately 650 grower and 950 weaner pigs were housed in the CF sections of the buildings. The tarpaulin partitions, erected across the buildings, were either attached directly to the roof line or hung from a wire at the eave-level of the building. This divided the buildings into two separate airspaces (Figure 15.1). The bottom of the tarpaulin wall was attached to the top of the existing pen wall. Hence air movement between each section was significantly reduced.

### 15.2.3 Experimental treatment

The AIAO building sections were cleaned thoroughly between each batch of pigs to completely remove the accumulation of dirt, dust and dung. The cleaning treatment included soaking, hosing and power-washing the walls, floors, ceilings and pen fixtures within the sections. The CF sections of the building were treated according to the existing farm procedure, which did not include regular cleaning.

The experimental setup ensured that the animals' genetics, medication, diet and general management (such as feeding, ventilation and effluent systems and husbandry) were identical for both CF and AIAO building sections.

### 15.2.4 Experimental animals

At the age of approximately 6 weeks, 100 pigs were randomly selected and tagged before being divided into two equal subgroups. One group was allocated to each treatment in each building. Conventional weigh-scales (Weigh Crate, Ruddweigh, Guyra, Australia) were used to monitor the ADG of the second-stage weaner (6 to 10 weeks of age) and grower (10 to 20 weeks of age) pigs in

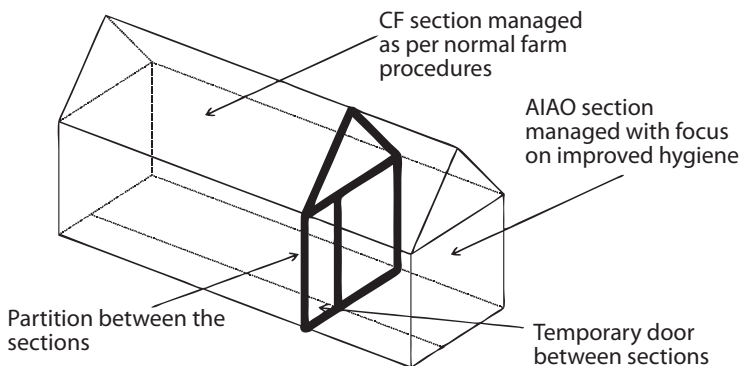

Figure 15.1. Drawing depicting the partitions erected in the buildings to create the separate sections.

both the experimental treatment groups. Tagged pigs were weighed each time they were moved, and when they were approximately 6, 12, 14 and 16 weeks of age. Over approximately a 2.5 year period, data was collected from seven batches of pigs, which were divided into the treatment groups. Approximately once a month, average daily gain (ADG), stocking density (SD), stocking rate (SR), temperature and AQ parameters were determined at the facilities.

### **15.2.5 Environmental and management related measurements**

The concentrations of airborne particles (total and respirable), airborne microorganisms (total, gram positive and fungi), NH<sub>3</sub> and carbon dioxide (CO<sub>2</sub>) were monitored to determine AQ in both the experimental and control building sections. The measurements were averaged for the monitoring period spanning between weight measurements and were treated as representative of the AQ conditions throughout the given period. Preliminary trials were undertaken before the main experiment, to determine the reliability/consistency of the measurement and the representative nature of airborne pollutant concentrations in the experimental and control sections.

#### *Particle measurement*

Concentrations of airborne particles were determined gravimetrically using cyclone samplers for respirable (<5 µm) and Institute of Occupational Medicine (IOM) samplers for total particles (Casella, Ltd., Kempston, UK), respectively. The sampling rate was set at 1.90 l/min for respirable particles and at 2.00 l/min for total particles, which were the standard sampling rates at the time of the study (Takai *et al.*, 1998). The samplers were connected to GilAir air pumps (Gilian Instrument Corp., West Caldwell, NJ, USA) and were usually placed above the walkways. To determine the concentration of airborne particles, the particles that the filters collected were weighed to the nearest 0.001 mg, in a controlled environment room.

On one occasion, an OSIRIS light-scattering instrument (Turnkey Instruments, Ltd., Northwich, UK) was used to monitor airborne particle distribution in the CF and AIAO sections of the weaner building (Figure 15.4). This measurement was used to demonstrate the consistent difference between the dust concentrations in the CF and AIAO section of the building. Both the OSIRIS particle monitors and the gravimetric filters were installed at a height of 1.1-1.3 m. For statistical comparison, only gravimetric measurements were used, due to the reliability of this particle measurement method (Takai *et al.*, 1998).

#### *Bacterial measurement*

A standard six-stage bacterial impactor was used to sample the total airborne microorganisms, gram positive bacteria and fungal species (Seedorf *et al.*, 1998). To determine the total number of bacterial, gram positive bacterial, and fungal colonies (colony forming units, or cfu), horse-blood agar (HBA) and selective plates (HBA+CAN and Sabourauds) were used (Medvet Science Pty. Ltd., Stepney, Australia), respectively. Samples were taken at about midday (11:00 h to 15:00 h), usually in the centre of the animal building and above the pens. The flow rate during sampling

## 15. Environmental and management effects associated with improved production efficiency

was 1.9 l/min, and the sampling time was 5 min. The exposed plates were incubated at 37 °C under aerobic conditions, and bacterial colonies were counted after 24 h.

### *Gas concentration measurements*

A multi-gas monitoring (MGM) machine was developed to continuously monitor NH<sub>3</sub> and CO<sub>2</sub> gases within the building sections. The machine incorporated an electrochemical gas monitoring head (Bionics TX-FM/FN, Bionics Instrument Co., Tokyo, Japan), and an infrared sensor (GMM12, Vaisala Oy, Helsinki, Finland) to detect internal concentrations of NH<sub>3</sub> and CO<sub>2</sub>, respectively. These components and other supporting electrical components were enclosed in a sturdy, shock-resistant electrical box. MGM machine's built-in air sampling system drew air samples into the gas monitoring heads from points located both inside and outside the buildings. The air was drawn at a nominal rate of 0.5 to 0.8 l/min from the sampling points. After each sampling point had been monitored for 15 minutes, the system was purged for 15 minutes with fresh air drawn from outside the buildings. This flushed out the sampling lines and enabled the NH<sub>3</sub> monitoring head to be re-calibrated to zero. In general, the sampling inlets were placed at a height of about 1.1 to 1.3 m during monitoring.

### *Stocking rate and density*

The SR (m<sup>2</sup> pen floor/pig) was calculated for each group of pigs after measuring the length and width of the pens in all sections of the farm. Similarly the volume of airspace in each building and section was also measured, and the SD (m<sup>3</sup> airspace/pig) calculated. The number of pigs in each section or airspace was recorded at each visit.

### *Air temperature monitoring*

In all buildings, temperature data was recorded using Tinytalk temperature loggers (Tinytalk-2, Hastings Dataloggers Pty. Ltd., Port Macquarie, Australia) (Banhazi *et al.*, 2008c). In general, these sensors were installed as close to the pigs' height as practically possible (above the pens), so that interference from the pigs was prevented.

### **15.2.6 Statistical method**

A number of statistical methods were used during this study, as it was difficult to identify significant effects using the data collected.

First, general linear models (GLM) were developed to explain as much variation in the dependent variable as possible (StatSoft, 2001). The dependent variable was the ADG of pigs in the AIAO and paired CF sections. The explanatory effects and covariates examined statistically were, total airborne particles (g/m<sup>3</sup>), respirable particles (g/m<sup>3</sup>), total airborne bacteria (cfu/m<sup>3</sup>), gram positive bacteria (cfu/m<sup>3</sup>), fungal species (cfu/m<sup>3</sup>), NH<sub>3</sub> (mg/m<sup>3</sup>), CO<sub>2</sub> (mg/m<sup>3</sup>) air temperature (°C), SR (m<sup>2</sup>/pig) and SD (m<sup>3</sup>/pig), in the AIAO and CF sections. As the number of data points available was limited, only main effects were tested. The statistical models were developed from the maximum model, by sequentially removing non-significant effects ( $P < 0.05$ , based on type



III estimable functions) until only significant effects remained. GLM statistical procedure was used, as it is able to interpret results reliably when handling unbalanced field data (StatSoft, 2001).

However, as only a few factors were identified separately for grower and weaner pigs; further analysis was undertaken based on the combined dataset. To minimise the natural variation caused by the ADG recorded for the weaner and grower pigs, the percentage change in ADG recorded in the AIAO and CF building sections was analysed as dependant variable using GLM procedure. The second analysis incorporated the same explanatory variables as in the first analysis.

The third analysis was designed to identify the relationship between the percentage change of key variables identified in the second analysis, and the percentage change in ADG recorded in the AIAO sections compared to the CF sections. ADG improvements were calculated in the same manner as in the second analysis. The combined percentage of AQ improvement was calculated by adding together the percentage change relative to continuous flow for ammonia, respirable and total particles and then dividing the calculated value by 3.00 as the maximum potential reduction (in %) for the three airborne pollutants was 300%. This was done to ensure that the calculated value is readjusted for a 0-100% scale; otherwise the combined reduction could have been more than 100%.

## **15.3 Results**

### **15.3.1 Reliability of measurements**

Figure 15.2 shows the NH<sub>3</sub> concentration recorded in the AIAO and CF sections of the grower building. The level of ammonia is consistently lower in the AIAO section.

On average for this recording period, the NH<sub>3</sub> concentrations for the AIAO and CF sections were less than 1 ppm, and 5.4 ppm respectively. The average ammonia concentrations remained relatively constant in both the AIAO and the CF sections.

Figure 15.3 shows a short comparative measurement taken with the OSIRIS optical particle counter. This measurement was taken to demonstrate the consistent reduction achieved in airborne particle concentration in the AIAO section compared to the CF section, and to validate the measurements taken with the gravimetric devices.

Although these measurements were not used during the statistical analysis, they provided confirmation that there were consistent differences in airborne pollutant concentrations in the AIAO and CF sections of the building.

## 15. Environmental and management effects associated with improved production efficiency

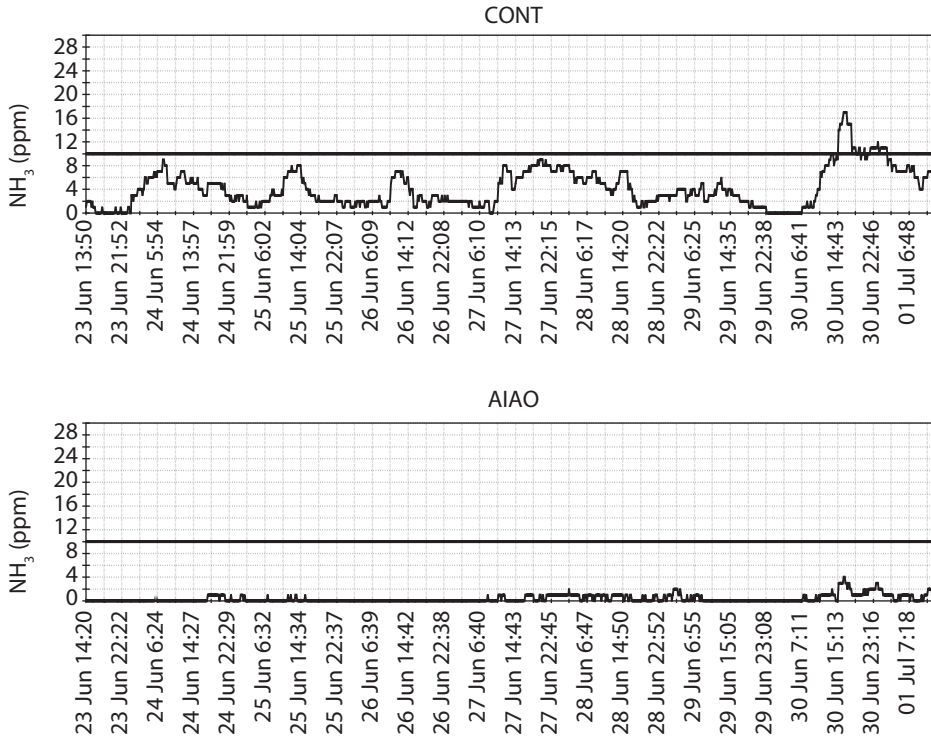

Figure 15.2. NH<sub>3</sub> concentrations (mg/m<sup>3</sup>) recorded in the CF and AIAO sections in the grower building.

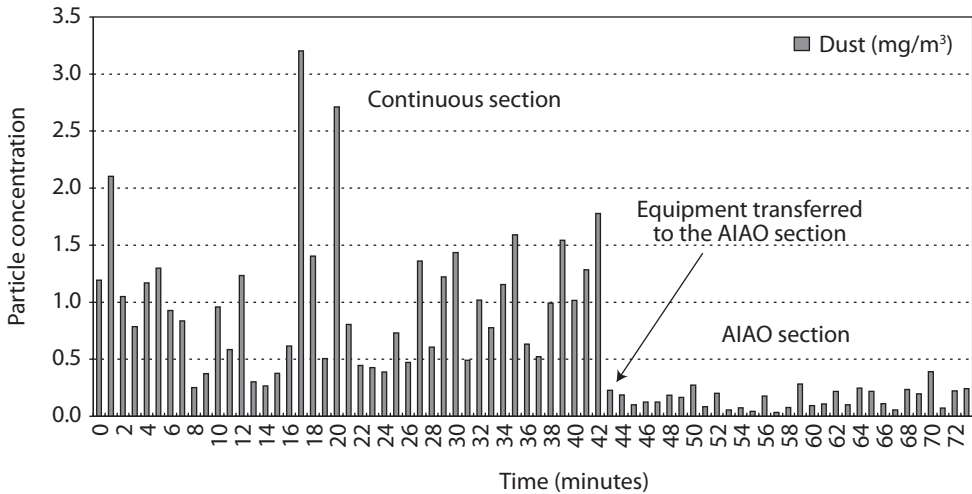

Figure 15.3. Change in particle concentrations over time in the AIAO and CF sections.

### 15.3.2 Average daily gain (ADG)

#### Initial analysis

Table 15.1 shows the mean, maximum and minimum values of the key parameters that were considered in the model developed for grower and weaner pigs. Figure 15.4 show the SR and SD data recorded in the AIAO and CF sections throughout the study.

These raw values indicated that environmental conditions were similar in both sections of the buildings (i.e. second stage weaner and the grower buildings.) This was not surprising as the management and structure of the second stage weaner building were very similar to the grower building. Both buildings were naturally ventilated with similar wall structure, insulation and ventilation systems.

Extreme values that deviated from optimal AQ were recorded in the grower building sections. For example, up to 1.1 mg/m<sup>3</sup> of respirable particulate concentration was recorded in the CF grower sections (Table 15.1). These levels are approximately four times the currently suggested upper limit for respirable particles (Banhazi *et al.*, 2008b; Donham *et al.*, 2000). Occasionally, the maximum concentrations of NH<sub>3</sub> and total airborne bacteria also exceeded suggested maximum limits (Table 15.1) (Banhazi *et al.*, 2008b, 2009).

Table 15.1. The mean, minimum and maximum ADG and pollutant concentration values recorded in the study buildings.

	AIAO			CF		
	Mean	Min.	Max.	Mean	Min.	Max.
Variables (grower)						
Average daily gain (g/day)	0.687	0.532	0.932	0.644	0.523	0.901
Total airborne particles (mg/m <sup>3</sup> )	0.779	0.121	1.328	1.706	0.727	2.954
Respirable particles (mg/m <sup>3</sup> )	0.159	0.032	0.417	0.446	0.031	1.076
Total bacteria (×1000) (cfu/m <sup>3</sup> )	128	57	174	158	101	195
Fungi (×1000) (cfu/m <sup>3</sup> )	17	3	31	21	4	36
NH <sub>3</sub> (mg/m <sup>3</sup> )	3.3	1.1	8.3	10.9	3.4	19.9
Variables (weaner)						
Average daily gain (g/day)	0.473	0.241	0.645	0.447	0.234	0.587
Total airborne particles (mg/m <sup>3</sup> )	0.770	0.288	1.298	1.494	0.679	2.889
Respirable particles (mg/m <sup>3</sup> )	0.255	0.088	0.619	0.652	0.128	1.472
Total bacteria (×1000) (cfu/m <sup>3</sup> )	132	81	175	154	103	201
Fungi (×1000) (cfu/m <sup>3</sup> )	20	3	41	21	6	48
NH <sub>3</sub> (mg/m <sup>3</sup> )	1.8	0.1	4.7	8.3	0.6	25.2

## 15. Environmental and management effects associated with improved production efficiency

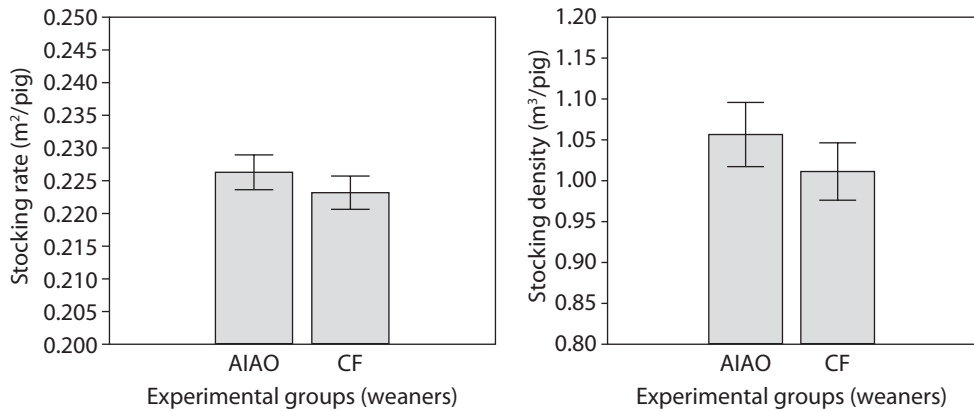

Figure 15.4. Average stocking rate and density values recorded within the AIAO and CF sections of the weaner building (mean  $\pm$  confidence interval).

The SR and SD were similar in both sections, however on average, in the AIAO section more air and floor space were available per pig (Figure 15.4). A one-way ANOVA indicated that the SR and SD values were not statistically different (SR and SD in the grower sections are not shown).

In the first analyses, a limited number of variables were identified that had an effect on ADG in the piggery buildings. The results of the analyses are summarized in Table 15.2 including the  $R^2$  values for the models developed.

One experimental effect and two covariates (concentrations of airborne microorganisms and fungal species) were identified as having a significant effect on the ADG of the pigs housed in the sections of the weaner building. One factor (experimental effect) and one covariate (SR) were identified as having a significant effect on the ADG of the pigs housed in the sections of the grower building (Table 15.2). The concentrations of airborne microorganisms and fungal species were negatively correlated with ADG, while SR was positively correlated. Pigs in both

Table 15.2. Tests of significance for effects associated with average daily gain (ADG) in the models developed.

	ADG	Slope
Effects for weaner sections (Model $R^2=34\%$ )		
Experimental effect (CF, AIAO)	$P=0.0375$	
Concentration of airborne fungal species (cfu/m <sup>3</sup> )	$P=0.0316$	negative
Concentration of airborne bacteria (cfu/m <sup>3</sup> )	$P=0.001$	negative
Effects for grower sections (Model $R^2=25\%$ )		
Experimental effect (CF, AIAO)	$P=0.0101$	
Stocking rate (m <sup>2</sup> /pig)	$P=0.0079$	positive

## T. Banhazi

AIAO sections had significantly higher ADG when compared with pigs housed in their paired CF sections. Experimental effects accounted for approximately 20% in  $R^2$  value achieved for both models. The models in (Table 15.2) indicate that the experimental effect, and to some extent, the improvements in SR and the reduction in the concentrations of airborne bacterial and fungal particles, were significantly associated with the improvement in production-efficiency observed for the pigs housed in the AIAO sections.

### Second analysis

Table 15.3 shows the data used in the second analysis. A summary of the analysis concerning ADG improvement percentages is presented in Table 15.4, which includes the  $R^2$  value for the model developed.

Throughout the study, an increase in airborne particle concentrations was not recorded in the AIAO sections, although at times, the reduction in the concentration of airborne particles was small (approximately 3%). The maximum reduction in the concentrations of airborne

Table 15.3. Mean, maximum and minimum percentage of change in average daily gain and pollutant concentration values recorded in the study buildings (AIAO vs. CF).

Change in variables (%)	Mean	Minimum	Maximum
Average daily gain	6.1	0.5	11.6
Total airborne particles	48.4	8.8	83.3
Respirable particles	51.2	3.2	88.9
Total bacteria	17.1	3.6	55.5
Gram positive bacteria	22.8	0.5	62.0
Fungi	16.5	5.6	69.7
NH <sub>3</sub>	68.8	-3.6	97.3
Stocking density	3.7	-4.4	9.4

Table 15.4. Tests of significance for effects associated with percentage improvement in average daily gain (ADG) in the model developed.

Effects for weaner sections (Model $R^2=58.9\%$ )	ADG	Slope
Reduction in the concentration of total airborne particles (%)	$P=0.0327$	positive
Reduction in the concentration of respirable particles (%)	$P=0.0029$	positive
Reduction in the concentration of ammonia (%)	$P=0.0425$	positive
Improvements in stocking density (%) <sup>1</sup>	$P=0.0044$	positive

<sup>1</sup> Increase in available airspace per pig.

## 15. Environmental and management effects associated with improved production efficiency

particles ranged between 85-90%, thus, the AIAO management did not completely eliminate airborne particle pollution. Across all batches of pigs, improvements in ADG varied between 0.5 (essentially no improvement) and 11.6%. On average, the respirable and total airborne particles were reduced by approximately 50% and the concentrations of viable airborne particles (total bacteria, gram positive bacteria and fungal species) were reduced by approximately 20%. The greatest reduction was achieved in the concentration of ammonia, however, on at least on one occasion the ammonia concentration increased by approximately 4% in the AIAO sections.

Four variables were identified during the second analysis that had a significant positive affect on the percentage-ADG. These variables were the percentage-change in concentration of (1) total airborne particles, (2) respirable particles and (3) ammonia. In addition, (4) the percentage of improvement in SD (i.e. more airspace availability per pig) was identified as the fourth factor. All of these variables were positively associated with ADG improvements. The model developed explained approximately 60% of the variation in ADG improvement.

### Regression analysis

The regression analysis shown in Figure 15.5 demonstrates a highly significant relationship ( $P=0.00006$ ) between the combined AQ parameters percentage change (i.e. combined percentages of reduction in the concentration of ammonia, respirable and total particles) and the per cent improvement in ADG. Figure 15.5 indicates that to trigger a positive effect on ADG; an improvement of between ~35-40% in the combined (and re-adjusted) concentrations of these airborne pollutants is required. Furthermore, the analysis indicates that by reducing these pollutants by up to 80%; an ADG improvement of between ~10-12% can be potentially expected.

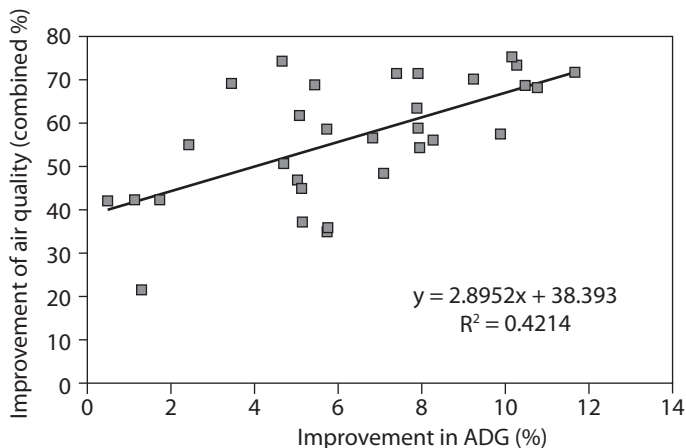

Figure 15.5. The relationship between percent improvement in average daily gain (ADG) and combined percent improvement in air quality in the study buildings (%).

### 15.3.3 Temperature and ventilation rate

Neither temperature (Figure 15.6a) nor CO<sub>2</sub> concentrations (indicator of ventilation levels, Figure 15.6b) were significantly different between the sections. These variables did not influence ADG in the weaner or grower sections either. These findings confirm the reliability of the study results, as according to the analysis these variables did not interfere with the main experimental effect of AIAO vs. CF management. The similarity between air temperatures and CO<sub>2</sub> concentrations recorded in the AIAO and CF sections of the weaner building can be observed in Figure 15.6. Results were similar in the grower buildings and are not shown here.

## 15.4 Discussion

### 15.4.1 Reliability of measurements

The initial measurements taken demonstrated that both the particle and ammonia measurements were highly likely to be representative of the AQ conditions in the AIAO and CF sections. The experimental treatment, involving cleaning of the AIAO sections between batches, consistently resulted in a reduction of airborne pollutants compared to that of the CF system. These concentration reductions can be observed in Figures 15.2 and 15.3.

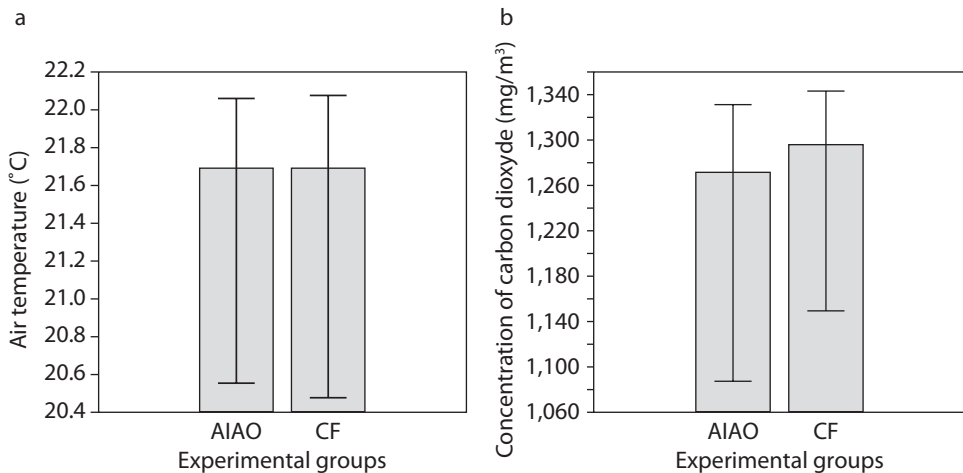

Figure 15.6. Similarities in (a) air temperatures and (b) CO<sub>2</sub> concentrations recorded within the AIAO and CF sections of the weaner building (mean ± standard error).

## 15. Environmental and management effects associated with improved production efficiency

### 15.4.2 Average daily gain

#### *First analysis*

The mean ADG of the pigs reared in the AIAO section of the grower building was 687 g/day from 10 weeks of age to slaughter. This was an increase of 6.7%, compared with the 644 g/day of pigs reared in the CF sections ( $P=0.01$ ) (Table 15.1). For pigs reared in the AIAO and CF sections of the weaner building the difference in ADG was 5.8% ( $P=0.04$ ). The mean ADG of pigs reared in AIAO section was 473 g/day from 6 weeks of age to 10 weeks, compared with 447 g/day for pigs reared in the CF sections (Table 15.1).

The effect of the experimental treatment (AIAO vs. CF section) was significant for both weaner and grower pigs (Table 15.2). The AIAO treatment can be considered a 'combination treatment' as it facilitates smaller group sizes and improved environmental conditions. Hence, this management method directly results in a reduced exposure level to a number of airborne pollutants. Because of that, it has to be acknowledged that based on the current study design; it was difficult to evaluate the influence of the management system *per se* (CF vs. AIAO) and the effects of air quality *per se*, as the two factors were naturally linked within this study. In addition, the potential effects of a 'permanent mixing' of pigs within the CF sections were not corrected within the study design. Even animals sourced from the same sow herd tend to have slightly different health and immune status. Thus, the mixing of pigs within the CF section most probably ensured a constant immune challenge of the CF animals. In addition, mixing unacquainted pigs typically results in fighting for the establishment of a social hierarchy. Thus animals in the AIAO sections definitely enjoyed better health and welfare status that most likely contributed to their improved production performance.

However, within the above mentioned limitations of the study, the statistical analysis highlighted the factors that were significantly associated with improved ADG. Only one covariate was identified as having a significant effect on ADG in the grower building and together with the experimental effect it only explained a very modest percentage of the observed variation in ADG ( $R^2=25\%$ ). Thus a large percentage of the variation was still unexplained. This relatively modest result could potentially be explained by the relatively small number of data points that were available for model development ( $n=16$  per treatment). In addition, the individual data points were highly variable as they were collected over a long period of time. Nonetheless, for growing pigs a reduction in SR (more floor space available per pig) was identified statistically as having a significant effect on ADG. This was so, despite the fact that the initial (exploratory analysis using simple one-way ANOVA) indicated no statistically significant differences in SR and SD between the experimental and control group. This highlighted the importance of using appropriate analysis methods when identifying statistically significant effects.

Evidently, weaner pigs responded well to a reduction in the concentrations of airborne microorganisms and fungal particles, with the statistical model developed explaining 34% of the variation observed in ADG for weaner pigs. Weaner pigs are more likely to be susceptible to bacterial challenge, even from micro-organisms which are not involved in well-defined specific infectious diseases. Thus, the reduction in the concentration of airborne bacteria may provide



reasoning why their production efficiency was positively affected. Approximately 14% of the variation in ADG was explained by the effects of airborne fungi and bacteria concentrations, while the experimental effect accounted for approximately 20% of the variation in ADG.

### *Second and third analysis*

The statistical analysis determined the factors that were significantly associated with percentage improvement in ADG (AIAO vs. CF sections). Four covariates were identified as having a significant effect on percentage of ADG improvement and the model developed explained a large percentage of the observed variation ( $R^2=60\%$ ). While approximately 40% of the variation in ADG improvement is still unexplained, the second model developed appears to be more robust than the first models (Table 15.4). This improvement in the model  $R^2$  value might be explained by the increase in available data points (by the virtue of combining the previously separated datasets for weaner and grower pigs) and by reducing the variation in ADG by converting absolute values into percentages. The covariates identified were the reductions in the concentrations of, ammonia (%), respirable (%) and total airborne particles (%). In addition, improvement in SD (% improvement in available airspace space per pig) was identified statistically as having a significant effect on ADG increase (%). According to the model, ADG of pigs was positively associated with the reduction in the concentrations of these key airborne pollutants.

The final regression analysis and the correlation depicted in Figure 15.5 further demonstrated the association between ADG improvements and combined reduction in the concentrations of the key airborne pollutants mentioned above. While the results of this study can still be regarded as limited, it is likely that certain level of airborne pollution reduction must be achieved, before any ADG improvement can be expected. The results of this study appear to confirm this theory and demonstrated that approximately 40% of combined airborne pollutant reduction must be achieved before ADG will increase. Similarly, the results of this study also shown that there might be an upper limit above which ADG increase cannot be expected.

The results achieved on this farm are in agreement with other publications (Cargill *et al.*, 1997,1998; Murphy *et al.*, 2012) and demonstrate the benefits of converting existing CF facilities into AIAO production systems, even in high health status herds. During this experiment, the AIAO management system allowed the facilities to be thoroughly cleaned between batches, which resulted in considerably improved air quality. It is likely that the better AQ and improved environmental conditions reduced the stress on the pigs' immune system, resulting in increased production efficiency (ADG) and thus potentially in financial gain. It is likely that the improved AQ maintained in the AIAO sections of the buildings also reduced the occupational health and safety risks for farm workers (Donham *et al.*, 1995).

### *Airborne pollutants*

There was a marked and consistent improvement in AQ in the AIAO sections throughout the experiment. When comparing the concentrations of different airborne pollutants recorded during this study using one-way ANOVA, it was demonstrated that concentrations of almost all airborne pollutants (including ammonia, total and respirable airborne particles) were significantly reduced

## 15. Environmental and management effects associated with improved production efficiency

( $P < 0.05$ ) in both the weaner and grower AIAO sections (results not shown). The percentage-reduction was noticeable for all pollutants in both AIAO sections when compared to their CF equivalents (Table 15.2). However, despite these significant reductions, only a handful of covariates were identified by the statistical models, as having a statistically significant effect on ADG (listed in Table 15.2). These results also highlight the importance of using appropriate statistical methods when analysing the results of studies implemented on commercial farms.

Notably, despite the large and significant reductions achieved in  $\text{NH}_3$ , total and respirable particle concentrations, these airborne pollutants were not identified as having significant influence on ADG during the initial analysis. It was thought that the highly variable nature of the independent data points obtained was partially responsible for these results. Thus a percentage of change in ADG improvements were analysed during the second analysis. A more robust statistical model was built during the second analysis that explained approximately 60% of the variation in ADG improvement. The combined AQ improvement was related to ADG improvement during the final analysis and the regression analysis demonstrated a strong correlation between these variables.

An important aspect of the study was to demonstrate the certain level of AQ improvement required to achieve a positive ADG response. Results indicate that ADG response would be expected to peak at approximately 12%. Although these results from this study make a lot of practical sense, further studies will be required to verify these results on other farms.

### *Stocking rate and density*

The SD and SR differences (identified by the GLM analysis as significant) were actually relatively small and statistically non-significant when initially analysed by simple one-way ANOVA. However, according to the analysis, even this relatively small difference in SR and SD had a significant impact on ADG and on the percentage of improvement in ADG. It is still questionable whether the identified effects were a causal effect or simply the identification of a parameter that was consistently better in the AIAO sections. Further experiments are needed to answer these questions. However, based on current results and on the results of previous publications (Cargill and Banhazi, 1996, 1998; Cargill *et al.*, 1996a,b), it appears that improved SR and SD is an important aspect of improved pig management. The reduced stress caused by greater available space and the potentially reduced heat stress due to reduced crowding (and thus better cooling opportunities for individual pig) might have contributed to this observed ADG improvement. In addition, it is also likely that the combined impact of a small SR and SD improvement per pig would add up to a significant improvement when assessed on a pen and/or on building level.

## 15.5 Conclusions

In summary, the experiment demonstrated the potentially positive effects of improved environmental conditions in piggery buildings. Two separate statistical models identified factors that had an effect on ADG in piggery buildings. These factors included, management (AIAO vs. CF management), SR and SD, concentrations of ammonia, airborne bacteria, airborne fungi, respirable and total particles. The pig in the AIAO sections had significantly higher ADG when compared with pigs housed in their paired CF sections. SR and SD were positively correlated

with ADG while the concentrations of all airborne pollutants were negatively correlated. Careful management of these factors could lead to the improved financial performance of the farm.

It is important to note that during this study a large and significant reduction in the concentration of airborne pollutants was achieved under commercial farming conditions. It would be expected that an ADG improvement would be experienced on other farms as well after reducing the concentrations of these pollutants. However, the extent of AQ improvements might vary between farms, and thus, might not translate to statistically significant ADG increase elsewhere. Especially in piggeries where high levels of building hygiene are maintained, additional improvements in hygiene and reduction in airborne pollutants may be difficult to achieve. Nevertheless, even ADG improvements that are non-significant statistically could result in significant economic gains on commercial farms.

## **Acknowledgements**

We wish to acknowledge the financial support of the Pig Research and Development Corporation (PRDC) and the important contribution of the manager of the study farm and piggery staff who kindly donated their time and facilities. We also would like to thank Dr. C. Cargill (South Australian Research and Development Institute, SARDI), who was instrumental managing and obtaining funding for a larger project that included this experiment. In addition, we sincerely thank Prof. John Black, (J. Black Consulting), Matthew Tscharke and Prof. J. Hartung (Hannover University, Germany) for their professional advice.

## **References**

- Banhazi, T., Holmes, G. and Purton, C., 2007. Dispersion modelling of dust impact area from different piggery buildings In: Banhazi, T. and Saunders, C. (eds.) SEAg 2007, Adelaide, Australia. SEAg pp. 106-112.
- Banhazi, T.M., Currie, E., Reed, S., Lee, I.-B. and Aarnink, A.J.A., 2009. Controlling the concentrations of airborne pollutants in piggery buildings. In: Aland, A. and Madec, F. (eds.) Sustainable animal production: the challenges and potential developments for professional farming. Wageningen Academic Publishers, Wageningen, the Netherlands, pp. 285-311.
- Banhazi, T.M., Rutley, D.L. and Pitchford, W.S., 2008a. Identification of risk factors for sub-optimal housing conditions in Australian piggeries – Part IV: Emission factors and study recommendations. *Journal of Agricultural Safety and Health* 14: 53-69.
- Banhazi, T.M., Seedorf, J., Rutley, D.L. and Pitchford, W.S., 2008b. Identification of risk factors for sub-optimal housing conditions in Australian piggeries – Part I: Study justification and design. *Journal of Agricultural Safety and Health* 14: 5-20.
- Banhazi, T.M., Seedorf, J., Rutley, D.L. and Pitchford, W.S., 2008c. Identification of risk factors for sub-optimal housing conditions in Australian piggeries – Part II: Airborne pollutants. *Journal of Agricultural Safety and Health* 14: 21-39.
- Cargill, C. and Banhazi, T., 1997. Using all-in/all-out management to improve air quality. *Manipulating Pig Production VI*. APSA, Corowa, Australia, pp. 293.

## 15. Environmental and management effects associated with improved production efficiency

- Cargill, C. and Banhazi, T., 1998. The importance of cleaning in all-in/all-out management systems. In: Cargill, C. and McOrist, S. (eds.) Proceedings of the 15<sup>th</sup> IPVS Congress. University of Birmingham, Birmingham, UK, pp. 15.
- Cargill, C., Banhazi, T. and Connaughton, I., 1998. The influence of air quality on production increases associated with all-in/all-out management. In: Cargill, C. and McOrist, S. (eds.) Proceedings of the 15<sup>th</sup> IPVS Congress. University of Birmingham, Birmingham, UK, pp. 248.
- Cargill, C.F. and Banhazi, T., 1996. The importance of limiting population size and density for providing optimal air quality in pig sheds. Proceedings 13<sup>th</sup> International Clean Air Conference, Adelaide, Australia. Clean Air Society of Australia and New Zealand, pp. 375-379.
- Cargill, C.F., Banhazi, T. and Connaughton, I., 1997. Converting existing continuous flow production to all-in/all-out: Health, production and financial implications, Proceedings of the AAVP Conference, Brisbane, Australia, pp. 60-63.
- Cargill, C.F., Banhazi, T. and Humphris, R., 1996a. Improving air quality and production by converting existing facilities to all-in/all-out systems, Proceedings of the 14<sup>th</sup> International Pig Veterinary Society Congress, Bologna, Italy, pp. 509.
- Cargill, C.F., Skirrow, S.Z. and Banhazi, T., 1996b. The relationship between pig population size, stocking density, air quality parameters and pleurisy in pig herds, Proceedings of the 14<sup>th</sup> International Pig Veterinary Society Congress, Bologna, Italy, pp. 521.
- Done, S.H., Chennells, D.J., Gresham, A.C.J., Williamson, S., Hunt, B., Taylor, L.J., Bland, V., Jones, P., Armstrong, D., White, R.P., Demmers, T.G.M., Teer, N. and Wathes, C.M., 2005. Clinical and pathological responses of weaned pigs to atmospheric ammonia and dust. *Veterinary Record* 3: 71-80.
- Donham, K.J., 2000. The concentration of swine production – effects on swine health, productivity, human health, and the environment. *Veterinary Clinics Of North America-Food Animal Practice* 16: 559-598.
- Donham, K.J., Cumro, D., Reynolds, S.J. and Merchant, J.A., 2000. Dose-response relationships between occupational aerosol exposures and cross-shift declines of lung function in poultry workers: Recommendations for exposure limits. *Journal of Occupational and Environmental Medicine* 42: 260-269.
- Donham, K.J., Reynolds, S.J., Whitten, P., Merchant, J.A., Burmeister, L. and Popendorf, W.J., 1995. Respiratory dysfunction in swine production facility workers: dose-response relationships of environmental exposures and pulmonary function. *American Journal of Industrial Medicine* 27: 405-418.
- Donham, K.J., Rubino, M., Thedell, T.D. and Kammermeyer, J., 1977. Potential health hazards to agricultural workers in swine confinement buildings. *Journal of Occupational Medicine* 19: 383-387.
- Dutkiewicz, J., 1997. Bacteria and fungi in organic dust as potential health hazard. *Annals of Agricultural and Environmental Medicine* 4: 11-16.
- Groot Koerkamp, P.W.G., Metz, J.H.M., Uenk, G.H., Phillips, V.R., Holden, M.R., Sneath, R.W., Short, J.L., White, R.P., Hartung, J., Seedorf, J., Schroder, M., Linkert, K.H., Pedersen, S., Takai, H., Johnsen, J.O. and Wathes, C.M., 1998. Concentrations and emissions of ammonia in livestock buildings in Northern Europe. *Journal of Agricultural Engineering Research* 70: 79-95.
- Kovacs, F., Nagy, A. and Sallai, J.-N., 1967. The effect of certain environmental factors on the health and production of pigs 2. Data on dust and living germ content as well as on the chemical contamination of the air in pig houses of closed system. *Hungarian Veterinary Journal* 22: 496-505.
- Lee, C., Giles, L.R., Bryden, W.L., Downing, J.L., Owens, P.C., Kirby, A.C. and Wynn, P.C., 2005. Performance and endocrine responses of group housed weaner pigs exposed to the air quality of a commercial environment. *Livestock Production Science* 93: 255-262.

## T. Banhazi

- Murphy, T., Cargill, C., Rutley, D. and Stott, P., 2012. Pig-shed air polluted by  $\alpha$ -haemolytic cocci and ammonia causes subclinical disease and production losses. *Veterinary Record* 171: 123.
- Seedorf, J., Hartung, J., Schroder, M., Linkert, K.H., Phillips, V.R., Holden, M.R., Sneath, R.W., Short, J.L., White, R.P., Pedersen, S., Takai, H., Johnsen, J.O., Metz, J.H.M., Groot Koerkamp, P.W.G., Uenk, G.H. and Wathes, C.M., 1998. Concentrations and emissions of airborne endotoxins and microorganisms in livestock buildings in Northern Europe. *Journal of Agricultural Engineering Research* 70: 97-109.
- StatSoft, I., 2001. *Statistica*. StatSoft, Inc., Tulsa, OK, USA.
- Takai, H., Pedersen, S., Johnsen, J.O., Metz, J.H.M., Groot Koerkamp, P.W.G., Uenk, G.H., Phillips, V.R., Holden, M.R., Sneath, R.W., Short, J.L., White, R.P., Hartung, J., Seedorf, J., Schroder, M., Linkert, K.H. and Wathes, C.M., 1998. Concentrations and emissions of airborne dust in livestock buildings in Northern Europe. *Journal of Agricultural Engineering Research* 70: 59-77.
- Urbain, B., Gustin, P., Charlier, G., Coignoul, F., Lambotte, J.L., Grignon, G., Foliguet, B., Vidic, B., Beerens, D., Prouvost, J.F. and Ansay, M., 1998. A morphometric and functional study of the toxicity of atmospheric ammonia in the extrathoracic airways in pigs. *Veterinary Research Communications* 208: 381-399.
- Von Essen, S. and Donham, K., 1999. Illness and injury in animal confinement workers. *Occupational Medicine-State of the Art Reviews* 14: 337-350.
- Wathes, C.M., Demmers, T.G.M., Teer, N., White, R.P., Taylor, L.L., Bland, V., Jones, P., Armstrong, D., Gresham, A.C.J., Hartung, J., Chennells, D.J. and Done, S.H., 2004. Production responses of weaned pigs after chronic exposure to airborne dust and ammonia. *Animal Science* 78: 87-97.
- Zejda, J.E., Barber, E., Dosman, J.A., Olenchock, S.A., McDuffie, H.H., Rhodes, C. and Hurst, T., 1994. Respiratory health status in swine producers relates to endotoxin exposure in the presence of low dust levels. *Journal of Occupational Medicine* 36: 49-56.

## 16. A proposed Livestock Burden Index (LBI) for airborne pollutants in livestock buildings

*J. Seedorf*

*University of Applied Sciences, Faculty of Agriculture and Landscape Architecture, Oldenburger Landstraße 24, 49090 Osnabrück, Germany; [j.seedorf@hs-osnabrueck.de](mailto:j.seedorf@hs-osnabrueck.de)*

### Abstract

The air in livestock operations contains considerable amounts of various airborne gaseous and particulate components. Inhaled airborne pollutants such as ammonia, dust or dust-related endotoxins can promote infectious and non-infectious diseases in the respiratory tract. Control measures to prevent such harmful accumulations are based mainly on recommended threshold limit values (TLVs). Such individually applied TLVs do not consider the interactions of all airborne pollutants on the respiratory tract. This is particularly true when the concentrations of airborne pollutants fall just below the exposure limits. Nevertheless, in such cases synergistic effects can be expected. To compensate for this limitation we propose a Livestock Burden Index (LBI) for airborne pollutants in pig and chicken housing. Published TLVs from behavioural and dose-response relationship studies were combined in a single formula to calculate the LBI, which considers airborne pollutants such as ammonia, inhalable dust, respirable dust and inhalable endotoxins. The calculated index indicates the magnitude of the pollutant burden in the air. The corresponding level of danger is expressed in five subjective descriptors ranging from slight to extreme. To demonstrate the applicability and the practicality of the LBI, it was retrospectively calculated for measured air quality factors in 48 German conventional livestock buildings. The survey shows that there are serious or extreme problems with the indoor air quality in 22% of all pig buildings and in 25% of all chicken buildings with potential detrimental effects on health and welfare. These values were compared with calculated LBI categories based on field data from Australian piggeries. Despite its preliminary model character the proposed LBI offers the possibility of incorporating further parameters or correction factors if the results of field investigations show that this is necessary. Future field investigations must be undertaken to demonstrate the general suitability of the LBI and its validity.

**Keywords:** airborne pollutants; threshold limit values; respiratory health; animal welfare; risk factors

### 16.1 Introduction

More than a quarter of a century ago, the European convention for the protection of farm animals defined the general microclimate conditions necessary for the physiological and ethological needs of livestock (EC, 1978). Nevertheless, it is generally agreed that the air quality within livestock buildings still remains a serious problem.

Airborne gaseous and particulate pollutants such as ammonia (NH<sub>3</sub>), dust, endotoxins (pro-inflammatory cell wall components of gram-negative bacteria) and microorganisms can

accumulate in the air in all types of husbandry systems.  $\text{NH}_3$  has been detected in mean concentrations of up to 18 ppm and 30 ppm in pig and poultry houses, respectively (Groot Koerkamp *et al.*, 1998). Inhalable dust can reach concentrations of  $5 \text{ mg/m}^3$  in pig houses, while laying hens in cages are exposed to approximately  $1 \text{ mg/m}^3$ , and broilers on litter have to cope with inhalable dust concentrations of up to  $10 \text{ mg/m}^3$  (Takai *et al.*, 1998). Inhalable endotoxin concentrations of up to  $187 \text{ ng/m}^3$  have been measured in pig confinement buildings. Nearly five times higher levels were found on average in poultry houses, although concentrations of approximately  $6,000 \text{ ng/m}^3$  are also possible in broiler houses (Seedorf *et al.*, 1998). In contrast to these observations overall mean concentrations of  $1.17 \times 10^5$  colony forming units (cfu) per  $\text{m}^3$  (bacteria),  $33.1 \text{ EU/m}^3$  (endotoxin), 3.7 ppm (ammonia),  $1.74 \text{ mg/m}^3$  (inhalable dust), and  $0.26 \text{ mg/m}^3$  (respirable dust) were found in Australian piggeries (Banhazi *et al.*, 2008b). The overall mean total viable, inhalable and respirable particle concentrations were  $5.27 \times 10^5 \text{ cfu/m}^3$ ,  $4.32 \text{ mg/m}^3$ ,  $0.84 \text{ mg/m}^3$ , respectively, in Australian broiler buildings (Banhazi *et al.*, 2008a).

Depending on individual susceptibility and the concentration of the atmospheric pollutant mixture, there are various negative biological impacts, especially in the respiratory tract, that need to be considered along with further environmental risk factors like herd size, stocking density, ventilation, hygiene and temperature (Banhazi *et al.*, 2008b,c; Stärk, 2000). An effective method for finding indications of the noxious effects of livestock-related airborne pollutants is the inspection of abattoir carcasses. Elbers (1991) found that about 50% of the lungs of inspected slaughtered pigs showed signs of fresh or earlier pneumonia, pleuritis or other respiratory afflictions. More than 24% of pig carcasses were affected by pneumonia alone (Von Altröck, 1998), and chronic pleuritis was the diagnosis in approximately 70% of all post-mortem recordings in slaughterhouses (Christensen and Enoe, 1999). A more recent study revealed that pathological lung findings were recorded for 50.4% of 584,778 inspected pig carcasses (Bostelmann, 2000), and that about 30% of the broilers rejected at meat inspection had lung lesions (Valentin *et al.*, 1988).

A great proportion of observed respiratory infections are due to specific pathogenic microorganisms (i.e. *Mycoplasma hyopneumoniae*, *Pasteurella multocida*). However, airborne pollutants also play a significant role in enzootic respiratory diseases such as atrophic rhinitis in pigs (Baekbo, 1990; Hamilton *et al.*, 1993, 1999). Bronchoconstrictions, bronchopneumonia or chronic obstructive pulmonary diseases are among the disorders associated with deficiencies in air quality within livestock buildings (Bollwahn, 1992; Clarke, 1987; Lekeux and Art, 1993). In addition to these clear pathological findings, antisocial behaviour such as cannibalism is also known to be caused by enriched airborne noxious components (Emeash *et al.*, 1997).

In theory, the negative health and productivity effects of air contaminants on animals can be limited by the application of air hygiene standards. For a selection of gases there are well-known recommended (CIGR, 1984) or legally fixed threshold limit values (Regulation for the Protection of Pigs in Livestock Buildings, 1994; Regulation for the Protection of Livestock Animals, 2001)<sup>4</sup>. No similar guidelines have yet been scientifically defined for dust. But in general, the application of such individual threshold limit values (TLVs) are not appropriate because they do not take into

---

<sup>4</sup> [www.gesetze-im-internet.de/tierschnutztv/index.html](http://www.gesetze-im-internet.de/tierschnutztv/index.html).



## 16. A proposed LBI for airborne pollutants in livestock buildings

account the mixture of airborne components found in the environment of animal production facilities and the combined impact these have on animals (Donham, 1991).

The aim of this study is to show the methodology of a proposed index formula which associates the risk of adverse effects with animal health and welfare. The index mathematically combines the TLVs of airborne pollutants to arrive at a single indicator value which represents the overall magnitude of burden. Additionally, the data pool from an air quality survey in livestock buildings was retrospectively used to demonstrate the general applicability and the practicality of such an index as opposed to the application of individual TLVs. Possibilities are also shown for the modification and extension of the index formula to include further factors.

### 16.2 Methodology

#### 16.2.1 Threshold limit values

A detailed review of the literature was made to discover the interdependencies between exposed concentrations of airborne pollutants and the biological responses of animals. With this in mind those experimental investigations were mainly considered which examined two or more air components and their biological effects on the respiratory tract. This was meant to take into account combined effects, which definitely occur under the environmental conditions within livestock buildings. In addition to clinical-pathological findings, some studies included the behavioural responses of animals exposed to varying concentrations of individual airborne pollutants; avoidance behaviour is interpreted as at least being an indication of discomfort.

When all these criteria were applied, only a small number of biologically justified TLVs could be found. In one experiment, Urbain *et al.* (1997) generated airborne inhalable and respirable dust (aerodynamic particle diameter of  $\leq 5 \mu\text{m}$ ) in an exposure chamber for pigs. Even minimum concentrations of  $4.4 \text{ mg/m}^3$  inhalable and  $0.54 \text{ mg/m}^3$  respirable dust induced airway inflammation (i.e. immune cell migration, albumin exsudation) in the exposed pigs. The potential synergistic effect of different airborne components became obvious when the animals were exposed to additional agents. When airborne endotoxins were additionally aerosolised in the exposure chamber, similar inflammatory effects occurred with concentrations of only  $3.4 \text{ mg/m}^3$  inhalable and  $0.32 \text{ mg/m}^3$  respirable dust (Urbain *et al.*, 1999). This threshold for effect-provoking concentrations was confirmed in principle by Donham (1991) and Donham and Cumro (1999), who correlated the results of housing air environment to swine disease and productivity in an epidemiological study. Donham found the following acceptable TLVs:  $3.7 \text{ mg/m}^3$  for inhalable dust,  $0.23 \text{ mg/m}^3$  for respirable dust,  $1,540 \text{ EU/m}^3$  (EU: endotoxin units) for inhalable endotoxins, and 11 ppm for ammonia.

Interestingly, this exposure limit for ammonia is close to that used in exposure experiments in combination with avoidance behaviour studies. In general, Smith *et al.* (1996) found that pigs prefer fresh air to ammoniated air. In a further experiment, the behavioural responses showed that just 10 ppm ammonia is sufficient for pigs to spend less time in a polluted compartment than in an unpolluted area (Jones *et al.*, 1996). Such avoidance behaviour is in strong agreement with experiments done by Hamilton *et al.* (1998), who found that 9 ppm  $\text{NH}_3$  lead to pathological



findings in the nasal turbinates of gnotobiotic pigs. On the basis of the studies by Donham and Cumro (1999) and Jones *et al.* (1996) we thus assume the following TLVs for pigs: 3.7 mg/m<sup>3</sup> inhalable dust; 0.23 mg/m<sup>3</sup> respirable dust; 1,540 EU/m<sup>3</sup> inhalable endotoxins; and 10 ppm ammonia.

Unfortunately, there is at present no substantial data base for TLVs for poultry in relation to dust. However, there are a few experiments that show the general association of minimised airborne dust and decreased lung lesions (Carpenter *et al.*, 1986) and the severity of lung-related ascites in broilers (Feddes *et al.*, 1997), but no biologically justified exposure limits for dust can be derived from these publications. However, a practical threshold limit value should be defined as a measure to meet the general welfare demands of chickens and counteract the impossibility preventing increasing dust concentrations in husbandry systems with bedding material or in aviaries. Such increases often occur during the winter, when air exchange rates are reduced. The inhalable dust concentrations within broiler production facilities can range between nearly 4 and 10 mg/m<sup>3</sup> (Takai *et al.*, 1998). A time-weighted exposure limit of 5 mg/m<sup>3</sup> is dictated by the Canadian Centre for Occupational Health and Safety for poultry dust (CCOHS, 2002). However, the transferability of such human-related threshold limits to chickens is problematic because of the obvious significant anatomical and physiological differences in the respiratory tracts of the two species. Nevertheless, maintaining a balance between the sometimes unavoidable high dust concentrations in chicken houses and the fulfilment of occupational hygiene standards may help to prevent excessive dust concentrations from occurring at all. As long as no scientifically confirmed exposure limits are available, a TLV of 6 mg/m<sup>3</sup> inhalable dust for chickens is a compromise which will probably improve the well-being of the chickens for the time being.

There are some studies of ammonia thresholds in poultry buildings. Depending on the species and length of exposure, the observed effect levels vary between 10 ppm for turkeys (Nagaraja *et al.*, 1983) to 25 ppm for broilers (Al-Mashhadani and Beck, 1985), due to different species-related susceptibilities. The threshold values for broilers are reflected in the results of a choice test in which laying hens were found to avoid compartments with at least 25 ppm ammonia (Kristensen *et al.*, 2000). Therefore, 25 ppm NH<sub>3</sub> seems to be a realistic minimum standard for the animal welfare demands of chickens.

### **16.2.2 Livestock burden index**

The Livestock Burden Index was conceived as a reflection of the burden of the most important and currently accepted airborne pollutants in livestock housing and includes their available individual TLVs. The overall idea is to determine how close the measured levels of airborne agents are to the TLVs. One such index was based on the mathematical principle of the summation of the relative concentrations of airborne components (Mayer *et al.*, 2002):

$$LBI = \sum_{i=1}^n \left[ \frac{C}{R} \right]_i \quad (16.1)$$

where C is the measured concentration in relation to R as the defined TLV of a specific component i. The symbol n indicates the number of airborne pollutants under consideration.

## 16. A proposed LBI for airborne pollutants in livestock buildings

The exposure limits of the airborne pollutants discussed in Section 16.2.1 were then integrated into the mathematical expression (denominators) of Equation 16.1. Since the endotoxin concentrations were measured in nanograms per cubic meter ( $\text{ng}/\text{m}^3$ ), a conversion factor was applied for the approximate conversion of endotoxin units into ng ( $10 \text{ EU} \approx 1 \text{ ng}$ ; Jacobs, 1997). The full LBI for pigs ( $\text{LBI}_p$ ) is thus:

$$\text{LBI}_p = \frac{C_{\text{NH}_3}}{10 \text{ ppm}} + \frac{C_{\text{ID}}}{3.7 \text{ mg}/\text{m}^3} + \frac{C_{\text{RD}}}{0.23 \text{ mg}/\text{m}^3} + \frac{C_{\text{IEtox}}}{154 \text{ ng}/\text{m}^3} \quad (16.2)$$

and for chickens ( $\text{LBI}_c$ )

$$\text{LBI}_c = \frac{C_{\text{NH}_3}}{25 \text{ ppm}} + \frac{C_{\text{ID}}}{6 \text{ mg}/\text{m}^3} \quad (16.3)$$

The subscripts  $\text{NH}_3$ , ID, RD and IEtox indicate the airborne components ammonia, inhalable dust, respirable dust and inhalable endotoxins.

As a first step the calculated numerical individual index values can be used to establish index classes indicating the magnitude of the burden to which the animals are exposed. Table 16.1 contains the proposed index classes. In a further step the observed status of the livestock and the corresponding necessity for counter-measures can also be interpreted in terms of these index classes (Table 16.2). More descriptive terms can be used instead of the purely numerical index classes: operating, precaution, alarm, intervention and worst case values. After the application of counter-measures (e.g. lowering animal density, increasing air exchange, using dust-reduced bedding material) the success of improved air hygienic conditions can then be re-evaluated by recalculating the LBI.

### 16.2.3 Air quality survey

As part of an European research project an air quality survey was carried out in 48 German commercially operated livestock buildings (32 pig and 16 chicken production facilities) which were typical of the area where the survey took place (Wathes *et al.*, 1998). The determination of airborne pollutants was carried out by means of a mobile laboratory containing most of the

Table 16.1. Index classes and magnitude of burden according to the proposed index value intervals for pigs and chickens.

Index class	Index interval pigs	Index interval chickens	Magnitude of burden
1	$0 \leq \text{LBI}_p \leq 2$	$0.0 \leq \text{LBI}_c \leq 1.0$	Slight
2	$2 < \text{LBI}_p \leq 3$	$1.0 < \text{LBI}_c \leq 1.5$	Moderate
3	$3 < \text{LBI}_p \leq 4$	$1.5 < \text{LBI}_c \leq 2.0$	Substantial
4	$4 < \text{LBI}_p \leq 5$	$2.0 < \text{LBI}_c \leq 2.5$	Serious
5	$5 < \text{LBI}_p$	$2.5 < \text{LBI}_c$	Extreme

LBI = Livestock Burden Index.

*Table 16.2. Index class and assumed corresponding livestock status and proposed counter measures to ensure welfare in pig and chicken livestock buildings.*

Index class	Rank order of alert values	Livestock status	Measures
1	Operating value	normal	no counter-measures
2	Precaution value	no direct threat to health and welfare not	no counter-measures
3	Alarm value	potential threat to health and welfare	preventive counter-measures should be initiated
4	Intervention value	likely threat to health and welfare	counter-measures have to be initiated
5	Worst case value	manifest threat to health and welfare	counter-measures have to be initiated immediately

analytical instrumentation mounted in a trailer, which was parked adjacent to the wall of the respective animal house. Six sampling points were distributed on a cross-sectional plane close to the centre of the respective animal house, with three points at the height of the animal breathing zone (0.5 m above ground for chickens, 1.5 m for pigs) and with three points at a higher level (1.5 m for chickens, 2.5 m for pigs) to monitor air flow patterns in the livestock house. The selected heights were an acceptable compromise for the measurement of the airborne pollutants directly adjacent to the animals while protecting the measurement equipment from damage by the animals. The following pollutants were measured at the indoor sites: ammonia, inhalable dust, respirable dust, and the endotoxins in the dust fractions. In each of the animal houses every measuring cycle comprised a 24-hour period always starting at 06:00 h and ending at the same time the next day. Each 24-hour measurement period was divided into two 12-hour sampling periods of day and night. Ammonia was measured continuously with a NO<sub>x</sub> analyser and an integrated ammonia converter. The measurement was based on the principle of chemiluminescence (Phillips *et al.*, 1998). The dust fractions and thus the endotoxins were sampled continuously via the filtration method. Gravimetric analysis was made of the 12-hour samplings only as a representation of the accumulated values of dust masses for the two 12-hour sampling periods. The mean of the two 12-hour sampling periods was used as an overall 24-hour average. Dust-related endotoxins were analysed with the aid of the turbidimetric-kinetic Limulus-Amebocyte-Lysate (LAL) gelation test. A detailed description of the monitoring concept and the used methods is given by Phillips *et al.* (1998) and Seedorf *et al.* (1998).

### **16.3 Demonstration of application and discussion**

Air quality (atmospheric) indices (AQI) are widely used to characterise air quality, and are often provided by national environmental protection agencies such as those established in the USA

## 16. A proposed LBI for airborne pollutants in livestock buildings

(EPA<sup>5</sup>) or in France (Airparif<sup>6</sup>). The AQI provides the population within a specific geographical area with information on the quality of the local air and on any associated health concerns (Mayer *et al.*, 2002). The most indicative air factors are integrated into an index formula, because, from a medical point of view, it is not just the concentrations of individual airborne pollutants that are of health concern; it is rather the total burden of all relevant pollutants together that must be taken into account.

The index calculation certainly leads to the loss of detailed information specific to each air factor in question. However, it is advantageous to combine different qualitative and quantitative airborne components in a single index, which makes it possible to highlight biological impacts with a single indicator number (Stoyan *et al.*, 1997). In this way, the overall air quality can be characterised without having to know threshold limit values for a range of individual airborne components. Although originally applied as a protective measure for human well-being, such indices should in principle also be applicable to animals, and an index for airborne pollutants in livestock buildings should also be an advantage in the evaluation of air hygiene and the assessment of the magnitude of the burden for confined farm animals.

Turner *et al.* (1993) defined an AQI which describes the interaction between air quality and the likelihood of infection in the case of atrophic rhinitis (AR) in swine. The calculation model was modified by using fuzzy logic to assess the effects of dust and ammonia on AR (Turner *et al.*, 1997). Unlike the swine-related AQI, the LBI is not limited to a specific infectious disease of pigs. As it includes four air factors, it gives more comprehensive insight into how the well-being of animals, including chickens, may be affected.

To demonstrate the principle of the proposed LBI, we compared the usefulness of individually applied threshold limit values to that of the calculated LBI for estimating animal well-being. Air quality surveys have shown that, depending on the type of air quality factor, the relative frequencies of exceeded TLVs are very heterogeneous (Table 16.3). When only individual TLVs were considered, most (72%) of the pig buildings were found to contain unacceptable concentrations of ammonia, whereas only few (not quite 13%) had unacceptable concentrations of inhalable dust. When counter-measures are deemed necessary only when concentrations of all four pollutants are over the limits, only 3% of the pig facilities would be affected. A similar tendency is also found in chicken facilities: whereas the air in 25% of the chicken buildings studied contained either ammonia or inhalable dust concentrations above their TLVs, the limits for both pollutants were exceeded in only 19% of these buildings, in which counter-measures would be required.

Clearly, neither individual threshold limits nor a combination of all available limits are suitable criteria for evaluating overall air quality. They also do not comprise a method for the unequivocal evaluation of the health and welfare of farm animals, nor can they serve as a guide for the justification of counter-measures in livestock buildings that fail to meet the limits. Due to these flaws, the principle of a binary risk assessment tool that determines only whether is the threshold

<sup>5</sup> [www.epa.gov/airnow/aqi\\_cl.pdf](http://www.epa.gov/airnow/aqi_cl.pdf).

<sup>6</sup> [www.airparif.asso.fr](http://www.airparif.asso.fr).

## J. Seedorf

Table 16.3. Percentage (%) of livestock buildings of pigs and chickens in which individual threshold limit values (TLV) were exceeded according to Seedorf (2003). The TLVs for pigs and chickens are given in brackets.<sup>1</sup>

	NH <sub>3</sub> (10 ppm)	ID (3.7 mg/m <sup>3</sup> )	RD (0.23 mg/m <sup>3</sup> )	IEtox (154 ng/m <sup>3</sup> )	All TLV exceeded
Pigs	71.9	12.5	34.4	6.3	3.1
	NH <sub>3</sub> (25 ppm)	ID (6.0 mg/m <sup>3</sup> )	n.a.	n.a.	Both TLV exceeded
Chickens	25.0	25.0			18.8

<sup>1</sup> ID = inhalable dust; RD = respirable dust; IEtox = inhalable endotoxins; n.a. = no TLV currently available for chickens.

limit value is exceeded or not is no longer be acceptable. Moreover, such a tool does not take into account the interactive impact of different airborne pollutants on animals, which is necessary in any case.

In this context the following questions arise:

- What happens when the concentrations of two or more pollutants fall just below the exposure limits? Is it possible that the animals then suffer due to synergistic effects of airborne pollutants?
- How should a range of different component-specific exposure limits be dealt with when the allowable exposure level of one component is exceeded but not that of another? Which TLV determines whether the air quality is sufficient or not?

Such uncertainties in risk assessment make evident the need for a method to define air quality in livestock buildings more comprehensively. Such a method should also be powerful enough to lead to a solution that compensates for the inconsistencies in the percentages of exceeded thresholds (Table 16.3) and eliminates the ensuing uncertainties in evaluation. The LBI may be a way to overcome these problems.

When the LBI is applied using Equations 16.2 and 16.3 and the same data pool as for the results in Table 16.3, 40.6% of all pig buildings and 37.5% of all chicken houses would fall in index class 3 or higher, indicating potential detriments to health and welfare. Nearly 22% of the pig building and 25% of the chicken houses would fall in index classes 4 and 5, indicating manifest health and welfare threats and the necessity for counter-measures (Table 16.2). However, approximately 59% of the piggeries and 63% of the poultry confinement operations have only slight to moderate problems in respect to concentrated airborne pollutants in livestock air. In an Australian air quality survey with 141 investigated piggeries, the relative frequency distribution among all index classes was notable different (T.M. Banhazi, personal communication). In contrast to German pig houses, a considerable number of Australian pig houses were within index class 5 (Table 16.4). This comparison between countries (or in general between different data samples) additionally

## 16. A proposed LBI for airborne pollutants in livestock buildings

Table 16.4. Relative frequency distribution of LBI-related index classes and associated magnitude of burden for pigs and chickens. Comparison between German and Australian piggeries.

Index class	Pigs (Germany) (%)	Pigs <sup>1</sup> (Australia) (%)	Chickens (Germany) (%)	Magnitude of burden
1	21.9	21.3	62.5	Slight
2	37.5	26.2	0.0	Moderate
3	18.8	14.2	12.5	Substantial
4	18.8	12.8	25.0	Serious
5	3.1	25.5	0.0	Extreme

LBI = Livestock Burden Index.

<sup>1</sup> Data provided by T.M. Banhazi, personal communication.

shows, that the LBI could also ease the evaluation of air hygiene of different livestock building clusters, which show clear differences in their internal and external characteristics (e.g. climate, husbandry type, management).

The results of applying the LBI differ in two important aspects from those in Table 3. First, more livestock buildings will fail to meet standards if it does not have to be shown that all airborne components exceed threshold limit values; this is a clear indication of the importance of combined effects. Secondly, the LBI is flexible enough to prevent the magnitude of burden from being overestimated when the concentration of only one component exceeds the limit. For example, the pig buildings in which only the ammonia threshold was exceeded (72%) would not automatically fail to meet standards without any consideration of the other important airborne components. Application of the LBI thus reduces the importance of individual cases of exceeded TLVs and guarantees that the total burden for animals in livestock buildings will be evaluated.

The last point involves a limit to the applicability of the LBI, but this is not insurmountable. When many different aerial pollutants are considered, most of which occur only in low concentrations, the importance of one very highly concentrated pollutant among them might be underestimated, even though the health implications of that pollutant cannot be ignored. For this reason additional practice-relevant precautions can be included in the LBI calculation. It could be stipulated that any considered component must not exceed its specific threshold limit value by a factor of three (or four, five, etc.), for instance, otherwise such a significantly concentrated airborne component is the cardinal factor, which then totally determine the potential health hazard by itself.

Another positive aspect of the LBI is its ability to be expanded to include other parameters. This is not an uncommon procedure for environmental indices. For example, the Temperature-Humidity Index (THI) is used to evaluate thermal challenges to livestock and to assess animal response to such challenges. The THI predicts the climate impact on livestock performance by assigning potentially heat-stressed animals to categories from normal to emergency (Hahn *et al.*, 2002). But it was found that the heat stress level could be determined more accurately by

introducing additional parameters like wind speed and solar radiation into the basic formula, thus modifying the THI to account better for field conditions (Mader and Davis, 2002). Therefore, similar adjustments in the LBI are also conceivable, for example if biological dose-response profiles of airborne pollutants or behavioural studies indicate corrections of the LBI are necessary in the future; this seems likely, because the four airborne components used here are probably only a small selection of potential biologically active agents in the air breathed by housed livestock. For example there is current discussion of whether inhaled dust-borne  $\beta$ -glucans have to be considered as potential inflammatory agents in the respiratory tract (Heederick *et al.*, 2000). Therefore, the expandability and flexibility of the LBI permits the inclusion of and calculation for other components to increase the accuracy of the model.

## **16.4 Conclusions**

Due to the complex interactions of qualitatively and quantitatively different airborne pollutants, their impact on animals cannot be evaluated reliably by mono-causal application of TLVs. The proposed LBI permits the assessment of the additive effect of important airborne pollutants on animal health and welfare. Therefore the LBI should provide veterinarians and other animal health and welfare professionals a practical and reliable decision-making tool for monitoring air hygiene standards and implementing counter-measures more effectively than with individual exposure limits.

Due to the model character of the LBI, future practical investigations in livestock operations will aim to develop and adjust the LBI to make the model better suited to different livestock housing conditions. It is to be hoped that the usefulness of a LBI will be confirmed in a broad range of applications. In particular, the proposed range of index intervals and their limits have to be tested under field conditions, and modified if necessary. This is also important if more or less pollutant factors are integrated into the equation in future, because the range of the index classes and index intervals, respectively, have then to be reconsidered. It also advantageous that other factors than air-related ones can be integrated into the formula, because many additional influences can be theoretically included that can be expressed numerically, like immune status (antibody titre), food quality (amount of toxic residues) and hygienic factors (amount of surface dirt). However, TLV like standards need to be developed for these proposed factors, if they are to be successfully incorporated into the LBI. Furthermore, in combination with other established indices such as the THI the LBI can describe the interaction between housed animals and their environment more accurately and efficiently.

Finally, the LBI will also contribute to consumer protection, by optimising indoor air quality and effectively preventing the accumulation of chemotherapeutical residues in diseased and treated farm animals.

## **Acknowledgements**

The main funding for this work was provided by the Commission of the European Union as Project No. PL900703. The author would like to thank the German farmers who allowed access to their buildings for the measurements. Special thanks are also addressed to Prof. Dr. J. Hartung,

## 16. A proposed LBI for airborne pollutants in livestock buildings

Institute for Animal Hygiene, Welfare and Behaviour of Farm Animals, University of Veterinary Medicine Hannover, Foundation, Germany, for his valuable advice. Special thanks are also addressed to Judith McAlister-Hermann for critical reading of the manuscript.

### References

- Al-Mashhadani, E.H. and Beck, M.M., 1985. Effect of atmospheric ammonia on the surface ultrastructure of the lung and trachea of broiler chicks. *Poultry Science* 64: 2056-2061.
- Baekbo, P., 1990. Air quality in Danish pig herds. Proceedings of the 11<sup>th</sup> Congress International Pig Veterinary Society, Lausanne, Switzerland, p. 395.
- Banhazi, T.M., Seedorf, J., Laffrique, M. and Rutley, D.L., 2008a. Identification of the risk factors for high airborne particle concentrations in broiler buildings using statistical modelling. *Biosystems Engineering* 101: 100-110.
- Banhazi, T.M., Seedorf, J., Rutley, D.L. and Pitchford, W.S., 2008b. Identification of risk factors for sub-optimal housing conditions in Australian piggeries – Part II: Airborne pollutants. *Journal of Agricultural Safety and Health* 14: 21-39.
- Banhazi, T.M., Seedorf, J., Rutley, D.L. and Pitchford, W.S., 2008c. Identification of risk factors for sub-optimal housing conditions in Australian piggeries – Part III: Environmental parameters. *Journal of Agricultural Safety and Health* 14: 41-52.
- Bollwahn, W., 1992. Infektionskrankheiten der Schweine. In: Mayr, A. and Scheunemann, H. (eds.) *Infektionsschutz der Tiere*. H. Hoffmann GmbH Verlag, Berlin, Germany, pp. 257-319.
- Bostelmann, N., 2000. Untersuchung über den Einfluß von Vermarkterorganisationen auf die Tiergesundheit und Fleischqualität von Mastschweinen anhand der am Schlachtbetrieb erhobenen Organbefunde, pH-Werte und Schinkenkerntemperaturen. Thesis, Freie Universität Berlin, Germany, 181 pp.
- Carpenter, G.A., Smith, W.K., MacLaren, A.P.C. and Spackman, D., 1986. Effect of internal air filtration on the performance of broilers and the aerial concentrations of dust and bacteria. *British Poultry Science* 27: 471-480.
- CCOHS, 2002. Control of exposure to biological or chemical agents. Canadian Centre for Occupational Health and Safety, Hamilton, ON, Canada. Available at: <http://www.oshforeveryone.org/leg/documents/ont/oneoha/onrbice0.htm>.
- Christensen, G. and Enoe, C., 1999. The prevalence of pneumonia, pleuritis, pericarditis and liver spots in Danish slaughter pigs in 1998 and comparison with 1994. *Dansk-Veterinaertidsskrift* 82: 1006-1015.
- CIGR, 1984. Climatisation of animal houses. Commission Internationale du Génie Rural, Report of working group, Scottish Farm Building Investigation Unit, Craibstone, Aberdeen, UK, 72 pp.
- Clarke, A.F., 1987. A review of environmental and host factors in relation to equine respiratory disease. *Equine Veterinary Journal* 19: 435-441.
- Donham, K.J. and Cumro, D., 1999. Setting maximum dust exposure levels for people and animals in livestock facilities. Proceedings on dust control in animal production facilities, 30 May-2 June, Aarhus, Denmark, pp. 93-110.
- Donham, K.J., 1991. Association of environmental air contaminants with disease and productivity in swine. *American Journal of Veterinary Research* 52: 1723-1730.
- EC, 1978. European Convention for the protection of animals kept for farming purposes. *European Council Official Journal L* 323: 14-22.
- Elbers, A.R.W., 1991. The use of slaughterhouse information in monitoring systems for herd health control in pigs. Thesis, Rijksuniversiteit Utrecht, Utrecht, the Netherlands, 152 pp.



- Emeash, H.H., Ali, M.M. and El-Bably, M.A., 1997. Effect of some pollutants as stressors on some behavioural patterns and performance of broiler chickens. *Veterinary Medical Journal (Giza)* 45: 307-314.
- Feddes, J.J.R., McGovern, R.H., Robinson, F.E., and Hanson, J.A., 1997. Respirable dust: effects on the incidence of ascites in broiler chickens. In: *Proceedings of the 5<sup>th</sup> International Symposium on Livestock Environment*, 29-31 May, Bloomington, MI, USA, Vol. II, pp. 632-637.
- Groot Koerkamp, P.W.G., Uenk, G.H., Metz, J.H.M., Phillips, V.R., Holden, M.R., Sneath, R.W., Short, J.L., White, R.P., Hartung, J., Seedorf, J., Schröder, M., Linkert, K.H., Pedersen, S., Takai, H., Johnsen, J.O. and Wathes, C.M., 1998. Concentrations and emissions of ammonia in livestock buildings in Northern Europe. *Journal of Agricultural Engineering Research* 70: 79-95.
- Hahn, G.L., Mader, T.L., Harrington, J.A., Nienaber, J.A. and Frank, K.L., 2002. Living with climatic variability and potential global change: Climatological analyses of impacts on livestock performance. In: *Proceedings of the 15<sup>th</sup> Conference on Biometeorology and Aerobiology*, 27 Oct-1 Nov, Kansas City, MI, USA, pp. 45-49.
- Hamilton, T.D.C., Roe, J.M., Hayes, C.M., Jones, P., Pearson, G. and Webster, A.J.F., 1999. Contributory and exacerbating roles of gaseous ammonia and organic dust in the etiology of atrophic rhinitis. *Clinical and Diagnostic Laboratory Immunology* 6: 199-203.
- Hamilton, T.D.C., Roe, J.M., Jones, P., Barnard, S. and Webster, A.J.F., 1998. Effect of chronic exposure to gaseous ammonia on the nasal turbinates of gnotobiotic pigs. *Inhalation Toxicology* 10: 753-764.
- Hamilton, T.D.C., Roe, J.M., Taylor, F.G.R., Pearson, G. and Webster, A.J.F., 1993. Aerial pollution: an exacerbating factor in atrophic rhinitis of pigs. In: *Proceedings of the 4<sup>th</sup> International Livestock Environment Symposium*, Warwick, American Society of Agricultural Engineers, p. 895-903.
- Heederick, D., Douwes, J., Wouters, I. and Doekes, G., 2000. Organic dusts: beyond endotoxin. *Inhalation Toxicology* 12: 27-33.
- Jacobs, R.R., 1997. Analyses of endotoxins. *International Journal of Occupational and Environmental Health* 3: S42-S48.
- Jones, J.B., Burgess, L.R., Webster, A.J.F. and Wathes, C.M., 1996. Behavioural responses to pigs to atmospheric ammonia in a chronic choice test. *Animal Science* 63: 437-445.
- Kristensen, H.H., Burgess, L.R., Demmers, T.G.H. and Wathes, C.M., 2000. The preferences of laying hens for different concentrations of atmospheric ammonia. *Applied Animal Behaviour Science* 68: 307-318.
- Lekeux, P. and Art, T., 1993. Mechanics of breathing in resting and exercising animals. In: Lekeux, P. (ed.) *Pulmonary function in healthy, exercising and diseased animals*. Vlaams Diergeneeskundig Tijdschrift, Ghent, Belgium, p. 67-91.
- Mader, T. and Davis, S., 2002. Wind speed and solar radiation corrections for the temperature-humidity index. In: *Proceedings of 15<sup>th</sup> Conference on Biometeorology and Aerobiology*, 27 Oct-1 Nov, Kansas City, MI, USA, p. 154-157.
- Mayer, H., Kalberlah, F., Ahrens, D. and Reuter, U., 2002. Analyse von Indizes zur Bewertung der Luft. *Gefahrstoffe-Reinhaltung der Luft* 62: 177-183.
- Nagaraja, K.V., Emery, D.A., Jordan, K.A., Newman, J.A. and Pomeroy, B.S., 1983. Scanning electron microscopic studies of adverse effects of ammonia on tracheal tissue of turkeys. *American Journal of Veterinary Research* 44: 1530-1536.
- Phillips, V.R., Holden, M.R., Sneath, R.W., Short, J.L., White, R.P., Johnsen, L.O., Hartung, J., Seedorf, J., Linkert, K.H., Schröder, M., Pedersen, S., Takai, H., Johnsen, J.O., Metz, J.H.M., Groot Koerkamp, P.W.G., Uenk, G.H. and Wathes, C.M., 1998. The development of robust methods for measuring concentrations and emission rates of gaseous and particulate air pollutants in livestock buildings. *Journal of Agricultural Engineering Research* 70: 11-24.

## 16. A proposed LBI for airborne pollutants in livestock buildings

- Seedorf, J., 2003. Die integrierte tier- und umwelthygienische Erfassung und Bewertung von Bioaerosolen in der Nutztierhaltung unter Einsatz eines mobilen Meßkonzeptes. Postdoctoral thesis (Habilitation), University of Veterinary Medicine Hannover, Foundation, Hannover, Germany, 215 pp.
- Seedorf, J., Hartung, J., Schröder, M., Linkert, K.H., Phillips, V.R., Holden, M.R., Sneath, R.W., Short, J.L., White, R.P., Pedersen, S., Takai, T., Johnsen, J.O., Metz, J.H.M., Groot Koerkamp, P.W.G., Uenk, G.H. and Wathes, C.M., 1998. Concentrations and emissions of airborne endotoxins and microorganisms in livestock buildings in Northern Europe. *Journal of Agricultural Engineering Research* 70: 97-109.
- Smith, J.H., Wathes, C.M. and Baldwin, B.A., 1996. The preference of pigs for fresh air over ammoniated air. *Applied Animal Behaviour Science* 49: 417-424.
- Stärk, K.D.C., 2000. Epidemiological investigation of the influence of environmental risk factors on respiratory diseases in swine – a literature review. *Veterinary Journal* 159: 37-56.
- Stoyan, D., Stoyan, H., and Jansen, U., 1997. Umweltstatistik. Statistische Verarbeitung und Analyse von Umweltdaten. B.G. Teubner Verlagsgesellschaft, Stuttgart-Leipzig, Germany, 348 pp.
- Takai, T., Pedersen, S., Johnsen, J.O., Phillips, V.R., Holden, M.R., Sneath, R.W., Short, J.L., White, R.P., Hartung, J., Seedorf, J., Schröder, M., Linkert, K.H., Metz, J.H.M., Groot Koerkamp, P.W.G., Uenk, G.H. and Wathes, C.M., 1998. Concentrations and emissions of airborne dust in livestock buildings in Northern Europe. *Journal of Agricultural Engineering Research* 70: 59-77.
- Turner, L.W., Gates, R.S., Wathes, C.M., Audsley, E., 1997. Using fuzzy logic for assessment of dust and ammonia effects on swine respiratory disease. In: *Proceedings of the 5<sup>th</sup> International Symposium on Livestock Environment*, 29-31 May, Bloomington, MI, USA, p. 638-646.
- Turner, L.W., Wathes, C.M. and Audsley, E., 1993. Dynamic probabilistic modelling of atrophic rhinitis in swine. *American Society of Agricultural Engineers: ASAE Paper No. 93-4559*, 14-17 December, Chicago, IL, USA, 20 p.
- Urbain, B., Beerens, D., N'Guyen, T.Q., Mast, J., Goddeeris, B., Cambier, C., Ansay, M. and Gustin, P., 1997. Chronic effects of dust inhalation on the respiratory tract in pigs. *Journal of Veterinary Pharmacology and Therapeutics* 20, Supplement 1: 291-292.
- Urbain, B., Mast, J., Beerens, D., N'Guyen, T.Q., Goddeeris, B., Ansay, M. and Gustin, P., 1999. Effects of inhalation of dust and endotoxin on respiratory tracts of pigs. *American Journal of Veterinary Research* 60: 1055-1060.
- Valentin, A., Bergmann, V., Scheer, J., Tchirch, I. and Leps, H., 1988. Tierverluste und Qualitätsminderungen durch Hauterkrankungen bei Schlachtgeflügel. *Monatshefte für Veterinärmedizin* 43: 686-690.
- Von Altröck, A., 1998. Untersuchungen zum Vorkommen bakterieller Infektionserreger in pathologisch-anatomisch veränderten Lungen von Schweinen und Zusammenstellung der Resistenzspektren. *Berliner und Münchener Tierärztliche Wochenschrift* 111: 164-172.
- Wathes, C.M., Phillips, V.R., Holden, M.R., Sneath, R.W., Short, J.L., White, R.P., Hartung, J., Seedorf, J., Schröder, M., Linkert, K.H., Pedersen, S., Takai, H., Johnsen, J.O., Groot Koerkamp, P.W.G., Uenk, G.H. and Metz, J.H.M., 1998. Emissions of aerial pollutants in livestock buildings in Northern Europe: overview of a multinational project. *Journal of Agricultural Engineering Research* 70: 3-9.



## **Part 6**

# **Hygiene and cleanliness**



## 17. Aiming at building cleanliness to keep livestock healthy

F. Madec

Anses, Zoopole, B.P. 53, 22440 Ploufragan, France; [francois.madec@anses.fr](mailto:francois.madec@anses.fr)

### Abstract

The words hygiene, sanitation, dirtiness and cleanliness, are all commonly used by the general public. Cleanliness refers to the avoidance of dirt, whereas hygiene can have a broader meaning. In animal farming, particularly when livestock are raised in total confinement, cleanliness is of utmost importance in health maintenance, even though it is not the sole factor. This chapter reviews the relationships between cleanliness and disease with special focus on multifactorial health disorders for which the immediate environment imposed on the animals is a major determinant. Building cleanliness and animal cleanliness are closely correlated. Therefore more attention has been paid to evaluating and maintaining animal cleanliness than to building cleanliness *per se*. Cleanliness is affected by the design of the buildings, especially the floor, and the internal equipment, as well as by their usage. The cleaning-disinfection process is of pivotal importance when raising livestock and must not be ranked as a 'minor chore'. It needs to be considered in the context of herd management and correct husbandry with emphasis placed on its role in reducing the microbial load and pathogen transmission. The efficacy of the cleaning-disinfection process can be assessed by laboratory investigations.

**Keywords:** animal housing, hygiene, cleaning, disinfection

### 17.1 Introduction

The positive relationship between cleanliness and health was demonstrated in humans many years ago (Fremantle, 1929). Similar conclusions were reached for farm animals, especially for udder health in dairy cows (e.g. DeHart *et al.*, 1976; Galton *et al.*, 1982; Jasper *et al.*, 1975). The common meaning of cleanliness, in relation to an object, is 'diligence in keeping clean', i.e. 'devoid of dirt'. This definition can easily be applied to farm animal production. However there is also a broader definition. Cleanliness can include the absence of dust, stains, bad smells and garbage. These aspects, i.e. absence of odour, avoidance of and need to avoid the spreading of dirt and contaminants, are often described by the term 'hygiene'. Even so, according to the etymology of the original Greek word (i.e. *hygieinos* = health), these aspects are far too limiting. Hence, the American Heritage dictionary (3<sup>rd</sup> edition, 1992) defines hygiene as 'the science that deals with the promotion and preservation of health' (Diesch, 1996). Hygiene can also be defined as preventive health care when appropriate methods and approaches are used to keep humans and animals healthy (R. Böhm, personal communication). Indeed, animal hygiene remains a subject in the veterinary curriculum in Germany and other European countries. Cleaning is obviously only one of the means involved in hygiene maintenance and disease prevention. Over-reliance on cleanliness in animal farming as the sole means of achieving health, and therefore a permanent obsession with dirt prevention, is questionable. There is no doubt that animals can accept sub-optimal e.g. dirty conditions, at least temporarily. However, in livestock production, the consensus is that cleanliness constitutes a major component of animal health maintenance and also of

veterinary health concerns in relation to public health. Nevertheless, the most appropriate criteria for assessing cleanliness are open to question (Dancer, 2004). They can depend on the material being cleaned, its usage and the degree of cleanliness required. Moreover, as cleanliness involves the removal of dirt, it inevitably implies removal of the associated micro-organisms. However, on a routine basis, efficient decontamination will require techniques specifically designed to destroy micro-organisms (i.e. disinfection), in conjunction with organic matter removal. The purpose of the present paper is to recall what is meant by cleanliness in buildings used for livestock and to review the practical means currently used to attain this goal. The relationship between cleanliness and susceptibility to animal health disorders will first be discussed and illustrated.

## **17.2 Cleanliness and health maintenance**

### **17.2.1 General considerations**

Diseases affecting livestock can be divided into different categories (Boon and Wray, 1989; Madec and Seegers, 2010) and it is recognized that the types of disease have changed considerably over the years. Under the current intensive and confined rearing conditions, multifactorial diseases are highly prevalent and a cause for great concern. Different systems of the body can be affected (i.e. locomotory, reproductive, respiratory, digestive...) and although these diseases are of multiple aetiology, the cause most often involves an infection. Disease occurrence and severity are dependent on the microbial pressure in the environment imposed on the animals. Needless to say, the environment in intensive confined farming systems is highly – if not totally – dependent on human care. The maintenance of cleanliness should therefore be a major goal as it directly or indirectly determines the impact of multifactorial diseases, (production diseases) by affecting the microbial load in the animal's immediate environment. In contrast, in the case of outbreaks of 'primary infectious diseases', e.g. Foot and Mouth Disease (FMD), Classical Swine Fever (CSF), this aspect of cleanliness will have little if any impact on the course of the disease, once a herd gets infected. However, a stamping out policy may be applied in many countries, involving strict procedures to clean the premises thoroughly once the infected herd has been removed. The goal is to reduce the risk of residual contamination which might compromise the health of incoming stock. A down-time period of several weeks is usually required after an outbreak before restocking. Beside outbreaks of notifiable diseases leading to stamping out, the farmer may decide to depopulate and then repopulate from a cleaner source of animals in other situations. This happens in the individual operations employed to eradicate certain embarrassing infections in pigs (e.g. porcine reproductive and respiratory syndrome, PRRS, Dee *et al.*, 1997) and implies meticulous and simultaneous cleaning of all the buildings between depopulation and repopulation.

The concept of cleanliness also includes biosecurity, which is commonly defined as the protection of health through avoidance of disease. Indeed the FAO directives deal with biosecurity in three steps: segregation (i.e. prevention of contact between infected and uninfected animals), cleaning, and disinfection (FAO, 2010). Only internal biosecurity falls within the scope of the current chapter and the question is how cleanliness can prevent or reduce disease expression and spread in farm operations. In this respect three aspects can be distinguished.

## 17. Aiming at building cleanliness to keep livestock healthy

Firstly, cleaning/disinfection should be integrated into the routine hygiene practices (i.e. husbandry). As mentioned earlier, multifactorial diseases occur because the pathogen pressure overwhelms the animal's resistance capacity. This is illustrated in Figure 17.1. In an age-segregated rearing system, accumulation of dirt and pathogens in the housing units can be prevented by cleaning/disinfecting all the buildings between successive groups of animals. This is also referred to as an all-in/all-out hygiene policy.

Secondly, cleanliness needs to be a target in other aspects of internal biosecurity. Keeping the buildings clean implies the implementation of strict measures against pathogen vectors such as houseflies or rodents. These pests may temporarily leave the barns when the livestock are removed (e.g. during downtime periods) and return after repopulation (Amass and Baysinger, 2006). They can usually find shelter in neighbouring buildings. Considerable efforts can be thwarted if these essential aspects of hygiene are not integrated into the daily routine.

Finally, all stockpersons need to be aware of the importance of cleanliness in many other tasks. The cleanliness of people *'per se'* is perhaps the most obvious. The mechanical role of people as vectors of pathogens has been clearly demonstrated but, all too often, this aspect of hygiene remains the Achilles' heel of farmers. Experimental studies showed that FMD could be transmitted by people who did not bother to wash their hands and change into clean clothes after being in

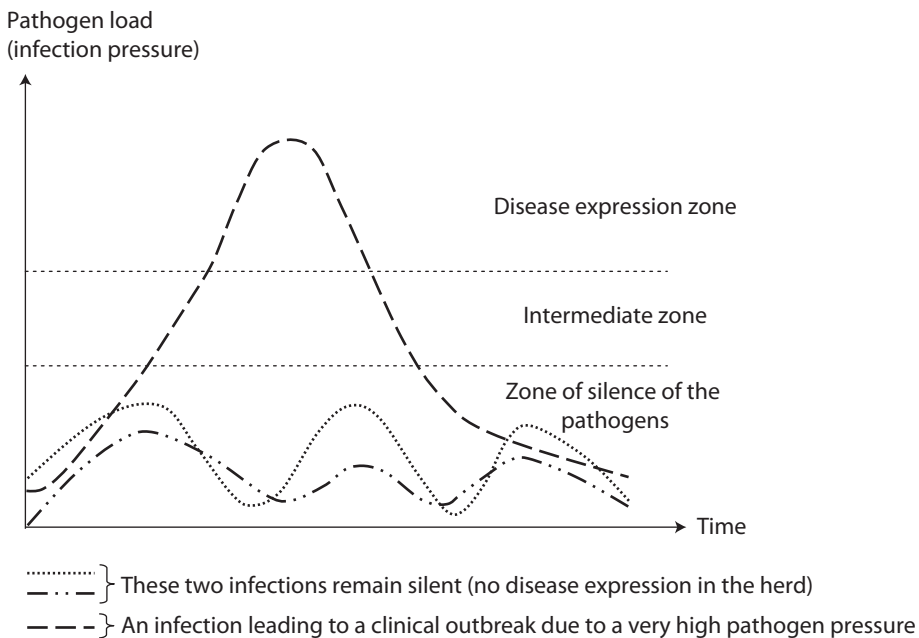

Figure 17.1. Multifactorial diseases. The pathogen *'per se'* can be handled so long as herd management and husbandry are adequate. However pathogens can take advantage of inadequacies or insufficiencies and the pathogens accumulate to a point resulting in clinical disease.



contact with diseased animals (Amass *et al.*, 2004). This point is particularly important where transmissible diseases are concerned, even if the pathogen has a lower spreading ability than the FMD virus. Pathogens (i.e. eggs of parasites, bacteria, viruses, etc.) can easily be transported on boots, clothes and hands, from rooms or compartments housing infected (seeder) animals to other places housing healthy and previously uninfected animals (Otake *et al.*, 2002). The quantity of pathogens transported can be especially high when people have close physical contact with sick animals. Another critical point is to use clean instruments for health care. Needles, for example, can be pathogen vectors and must be changed or cleaned and sterilized after use (Amass and Baysinger, 2006). These aspects of cleanliness can often be overlooked when routine procedures are performed in a rush with little mindfulness of their importance. Designers of animal houses need to take the various hygiene operations into account. There should be a special place for changing boots and clothes, as well as for hand washing, between the main compartments or herd sectors of the farm buildings.

An unavoidable relationship exists between the cleanliness of the floors and equipment inside livestock buildings and the cleanliness of the animals that they house. As regards health and welfare, the survival of pathogens in dirt is important from an epidemiological standpoint, as illustrated in Table 17.1. Dirt (e.g. manure) can clearly serve as a reservoir for further contamination on infected farms and sometimes for a very long time (e.g. eggs of *Ascaris suum*). Table 1 also shows the huge differences that exist between virus survival capacities in manure. Parvovirus, a non-enveloped virus, is particularly resistant and often used as a target pathogen to test the efficacy of disinfectants. As regards health maintenance, it makes common sense to avoid contact of the animals with manure and faeces, or at least reduce it as much as possible. All surfaces in contact with the animals are concerned in the context of building cleanliness. Hence floor design is an important factor affecting diseases resulting from foot or leg trauma and diverse injuries that can become infected from mud. Hygiene must be taken into account when designing floors so that they can be easily and efficiently cleaned (Boon and Wray, 1989). These authors, for instance, advise leaving a slot by the walls to prevent the frequent build-up of faeces, which can be difficult to remove, and state that attention to detail in building design could facilitate hygiene operations at numerous sites. Keeping the immediate environment clean results in reduced infection pressure and less exposure of the animals to potential pathogens.

### **17.2.2 Cleanliness and health in dairy cattle**

Cleanliness inside livestock buildings is not always assessed directly or evaluated quantitatively. Instead, scientists tend to focus on the animals, especially when these are dairy cows, knowing that cow cleanliness and state of the floor are closely correlated (Faye and Barnouin, 1985). These investigators drew up a farm cleanliness index to reflect both the state of the dairy cows and their housing. Apart from aesthetic considerations, there are other good reasons why cows should be kept in conditions that avoid soiling (Hughes, 2001). The somatic cell count (SCC) of milk is related to barn hygiene. Herds with a low bulk SCC had cleaner housing and thus cleaner cows than herds with a higher bulk tank SCC (Barkema *et al.*, 1998, Köster *et al.*, 2006). Several authors reported a positive correlation between cow cleanliness and udder or hoof health (e.g. DeHart *et al.*, 1976; Ekesbo, 1996; Galton *et al.*, 1982; Neave *et al.*, 1966). The interest of having clean animals was later emphasized for public health reasons, especially in the UK, following the crisis

## 17. Aiming at building cleanliness to keep livestock healthy

Table 17.1. Survival times for selected pathogens in manure (adapted from Amass and Baysinger, 2006; Boye et al., 2001; Haas et al., 1995; Marti et al., 1980).

	Micro-organism	Temperature (°C)	Survival time
Parasites	<i>Metastrongylus</i> eggs	12	+ 68 days
		22	+ 47 days
	<i>Metastrongylus</i> larvae	12	36 days
		22	+ 47 days
	<i>Oesophagostomum</i> eggs	12	4 days
		22	7 days
	<i>Oesophagostomum</i> larvae	12	+ 68 days
		22	11 days
	<i>Ascaris suum</i> eggs	ND	5 years
	<i>Strongyloides ransomi</i> eggs	12	7 days
		22	7 days
	<i>Strongyloides ransomi</i> larvae	12	21 days
22		13 days	
Bacteria	<i>Salmonella</i> spp	6-9	1.6-5.9 weeks
		18-20	0.6-2 weeks
	<i>Pasteurella multocida</i>	4	3 days
	<i>Streptococcus suis</i>	9	10 days
Viruses	<i>Brachyspira hyodysenteriae</i>	10	112 days
		20	3 hours
	Bovine Viral Diarrhoea virus (BVD)	5	3 days
		20	3 hours
	Inf Bovine Rhinotracheitis virus (IBR)	5	+ 4 weeks
		20	2 days
	Foot and Mouth Disease virus (FMD)	5	+ 14 weeks
		20	2 weeks
	Swine Influenza virus (SIV)	5	9 weeks
		20	2 weeks
Porcine parvovirus (PPV)	5	+ 40 weeks	
	20	+ 40 weeks	

involving *Escherichia coli* O157 in the middle of 1990s. Much greater attention was paid to the subject when cattle had to be slaughtered.

Many methods and scales have been published for scoring cleanliness/dirtiness in dairy cattle. Some of them are listed with their characteristics in Table 17.2. They are based on a subjective evaluation of cleanliness without the use of any accompanying device. Their ease of implementation depends on the number of sites to be examined. However, they are less appropriate for use in tied cows (Hultgren and Bergsten, 2001).

Table 17.2. Different cleanliness scoring systems for dairy cows.

Reference	Main principle	Scale of scoring
Faye and Barnouin, 1985	5 anatomical sites: <ul style="list-style-type: none"> <li>• ano-genital</li> <li>• udder (hind)</li> <li>• udder (side)</li> <li>• leg, above hock, thigh</li> <li>• foot and leg (below hock)</li> </ul>	For each area: from 0 (clean) to 2 (dirty) Scale: 0, 0.5, 1, 1.5 and 2
Scott and Kelly, 1989	35 body areas	For each area: from 0 (clean) to 3 (dirty) The individual scores are added up to give a final global score (theoretical maximum = 105)
Hughes, 2001	4 anatomical sites: <ul style="list-style-type: none"> <li>• flank</li> <li>• hind legs</li> <li>• udder</li> <li>• tail</li> </ul>	From 1 (very clean) to 5 (heavily soiled), per site
Hultgren and Bergsten, 2001	9 separate body divisions: <ul style="list-style-type: none"> <li>• left and right hind foot</li> <li>• left and right hind leg</li> <li>• left and right thigh</li> <li>• left and right side of udder</li> <li>• hind part of udder</li> </ul>	4 level ordinal scale (0 = clean or almost clean; 3 = more than half of the area covered by manure)
Schreiner and Ruegg, 2002	2 anatomical sites: <ul style="list-style-type: none"> <li>• udder</li> <li>• hind legs</li> </ul>	From 1 (completely free of dirt or has very little dirt), to 4 (completely covered, caked with dirt), per site
Reneau <i>et al.</i> , 2005	5 body areas: <ul style="list-style-type: none"> <li>• tail head</li> <li>• lateral aspect of the thigh (upper portion of the hind limb)</li> <li>• ventral aspect of the abdomen</li> <li>• udder</li> <li>• lower portion of the hind limbs</li> </ul>	From 1 (very clean) to 5 (very dirty), per area
Fulwider <i>et al.</i> , 2007	Overall scoring, focus on: <ul style="list-style-type: none"> <li>• legs</li> <li>• udder</li> <li>• ventral abdomen</li> </ul>	Scale: 1 to 5 1 = clean 2 = manure stains but no visible dried manure on the legs or udder 3 = dried or wet manure on legs or udder 4 = heavily soiled 5 = very heavily soiled: udder, legs, abdomen

## 17. Aiming at building cleanliness to keep livestock healthy

### *Cleanliness and udder health*

In lactating dairy cows, the mammary gland is subjected to an intense physiological process. The challenge in high yielding cows is particularly demanding and keeping the udder healthy is of prime importance (Figure 17.2). The major problem encountered in the field is mastitis, which is both common and costly. The estimated incidence of clinical mastitis was around 30 cases/100 cows 'at risk', per farm per year on conventional farms in the Netherlands (Jansen *et al.*, 2009). The condition is often referred to as 'coliform mastitis' (Hogan and Smith, 2003). The correctness of this term is open to debate as it often encompasses mammary diseases involving Gram-negative bacteria (such as *Pseudomonas*, *Proteus*, *Serratia*, etc.) which are not classified as coliforms. Coliform Gram-negative bacteria (e.g. *E. coli*, *Klebsiella*, *Enterobacter*) are considered as environmental mastitis pathogens.

Coliforms are normal inhabitants of the gastrointestinal tract in mammals and are found in the faeces. Gram-negative bacteria can be found on building equipment (e.g. surfaces: floors, rubber hoses) as well as on the cow's body. Although the mammary gland is not considered a natural habitat for coliforms, many strains are capable of surviving and multiplying in the mammary gland (Hogan and Smith, 2003). Many infections acquired during the dry period can persist to lactation when they may develop into clinical cases. The relationship with udder hygiene (in the cleanliness sense) has been investigated in many countries under contrasting farming conditions. In the USA, a significant association was reported between the prevalence of contagious intramammary pathogens (i.e. *Streptococcus aureus*, *Streptococcus agalactiae*) and udder hygiene score (Schreiner and Ruegg, 2003). Moreover, major pathogens (i.e. contagious pathogens +



Figure 17.2. There is evidence that udder health is favoured when the dairy cows are maintained clean (photo: Anses, Ploufragan).

environmental pathogens: *E. coli*, *Klebsiella*, etc.) were 1.5 times more likely to be isolated from milk samples obtained from cows with poor udder hygiene scores, than from cows with good scores. In another survey also performed in the USA and focused on *Klebsiella* bacteria (Munoz *et al.*, 2008), the authors found that teats on dirty udders were significantly more likely to test positive for bacteria, after udder preparation, than teats on clean udders. Similar proportions of *Klebsiella pneumoniae* and *Klebsiella oxytoca* isolates were isolated from teat end swabs and cases of clinical mastitis. The authors suggested that udder cleanliness should be used as a management tool for monitoring the risk of *Klebsiella*. It was concluded from data obtained from a mastitis control programme and expert observations in France that the probability of a herd belonging to a group with a low somatic cell score was maximized when (amongst other things) the winter cleanliness of the dry cow shed was good (Chassagne *et al.*, 2005) whereas high somatic cell scores were obtained in dirty sheds. The relationship between cleanliness and udder health was recently investigated in a study carried out in the Netherlands on dairy farms using an automatic milking system (Dohmen *et al.*, 2010). The annual average herd somatic cell count (SCC) was positively related to the proportion of cows with dirty teats before milking and to the proportion of cows with dirty thighs. Similarly, at the individual cow level, the hygiene score was related to the cow SCC obtained on the milk production test day closest to the farm visit. The SCC of the cow was positively related to the udder hygiene score. The authors emphasized the relevance of measuring cow cleanliness when assessing hygiene on a dairy farm.

### *Cleanliness and claw health*

Claw disorders have a direct effect on animal welfare and can have considerable economic implications due to milk production losses, reduced fertility and earlier culling. In the middle of 1990s, in the UK, the total estimated costs of lameness, including the reduction in milk yield per affected cow were 240 £ and 131 £ for digital and interdigital disease, respectively (Kossaibati and Esslemont, 1997). High prevalence of claw disorders is reported in the literature. In the Netherlands where more than 40,000 cows were carefully examined during claw trimming, 69% of the animals had at least one claw disorder (Van der Linde *et al.*, 2010). Fortunately not all claw disorders result in lameness. The estimated prevalence of lameness on dairy farms in the UK was 39% for zero-grazing herds and 15% for grazing herds (Haskell *et al.*, 2006). More recently, the mean lameness prevalence was as high as 36% in a survey of 205 dairy farms in England and Wales although the variation between farms was very large (range: 0-79%, Barker *et al.*, 2010). In a literature review, Cook and Nordlund (2009) estimated that, at any one time, approximately 20% of intensively managed dairy cows worldwide were lame. In the USA a positive correlation was found between the percentage of cows reported lame in herds on the day of a survey inspection and the somatic cell count (Fulwider *et al.*, 2007). Foot dirtiness is commonly observed in cows. Hoof dirtiness attained an unacceptable level in around 40% of dairy cows in a Swedish survey (Manske *et al.*, 2002). A low-to-moderate positive correlation was found between foot health and cleanliness in tied dairy cows in Sweden (Hultgren and Bergsten, 2001). The pathogenesis of digital dermatitis remains unclear. Experimental trials designed to induce dermatitis failed when pure cultures of pathogens (e.g. *Treponema* spp.) were inoculated into the interdigital skin. Additional conditions such as those found in the buildings or exercise yards i.e. dirty, humid environments, were required (Berry, 2006). One explanation could be that wet, unhygienic floor conditions result in softening of the digital horn, making the claw capsule more susceptible to

## 17. Aiming at building cleanliness to keep livestock healthy

abrasion and bacterial invasion (Greenough *et al.*, 1997). It can be concluded, in confirmation of earlier statements, that poor floor and skin surface hygiene are key factors exacerbating problems of infectious lameness (Cook and Nordlund, 2009).

Obviously many other health disorders can affect the dairy cow and the reasons for their onset can be diverse. However there is strong evidence that hygiene has a direct or indirect causal role in many of them. As a result, control programmes aimed at improving cleanliness have been designed and include interventions and management practices. Tail docking was proposed but in view of the major disadvantages (e.g. animal welfare problems) and the lack of obviously improved cleanliness as a result of docking, the authors saw few benefits in adopting this procedure (Schreiner and Ruegg, 2002; Tucker *et al.*, 2001). Efforts need to be directed at building design and equipment. When tie-stall operations were investigated in Canada, few of them fell within the standard recommendations (Zurbrigg *et al.*, 2005). It was concluded from one study of tied dairy cows in Europe that having partitions between adjacent animals could be an advantage (Aland *et al.*, 2009). The cows behaved differently and were able to stay cleaner. In another study, the risk of getting dirty was found to be significantly lower on a rubber-slatted floor than on a solid stall floor (Hultgren and Bergsten, 2001). In the USA, different types of floor were tested in free-stall dairies (Fulwider *et al.*, 2007). The hygienic state of cows kept on rubber-filled mattresses and ‘waterbeds’ was better than if they were kept on sand beds. In free-stalls, keeping the alley floors clean was also shown to have a beneficial effect on udder cleanliness. The situation was greatly improved by using scrapers (Magnusson *et al.*, 2008). However, designing buildings which provide all the advantages whilst avoiding all the disadvantages remain challenging if not utopian. Contradictory effects have to be dealt with and the best compromises adopted. Hence neck rails were found to improve stall and udder hygiene but to increase lameness (Bernardi *et al.*, 2009). In any case, building designers need to give consideration to animal health in the long run. This means that the daily use of the buildings and internal equipment needs to be taken into account, knowing that a given building or device may give different results in terms of animal health and welfare depending, in particular, on the methods employed and the skill of the stockpersons using them. In addition, many potential interfering factors, such as characteristics of the actual livestock also need to be considered.

### 17.2.3 Cleanliness and health in pigs

The common saying: ‘dirty as a pig’ indicates, more than anything else, the strong relationship that has been established between pigs and dirtiness by the general public. Unfortunately the pig has been encumbered with this negative reputation for many centuries, notwithstanding the fact that it is neither justified by scientific evidence nor by daily on-farm observations. Certainly the pig naturally performs behavioural activities such as dung foraging or wallowing when suitable environmental conditions are offered. It is even perceived as happy when doing so (Lassen *et al.*, 2006). On the other hand, in the common barren farming environment, when given the choice of playing objects which are clean vs. soiled, the pig clearly prefers the clean ones (Bracke, 2007). Clean toys are even preferred to noisy ones!

As in dairy cows, and despite the fact that designing and managing piggeries to maintain cleanliness remains challenging, hygiene is a key component of disease prevention. The terms

'hygiene' and 'sanitation' tend to be used more often than cleanliness, in scientific literature dealing with pig production. The goal of hygiene is to minimize the acquisition of pathogens from the environment. Sanitary measures have been promoted as highly effective means of disease control but are often overlooked in favour of biotechnical or less labour-intensive methods (Straw, 1992). Intense and frequent contact between the pigs and their faeces tends to increase faecal-oral contamination and recycling of pathogens resulting, for example, in more ascaris scars in the liver (Lindquist, 1974). Poor, in contrast to good hygienic conditions, have been associated with a higher incidence of enteric disorders in nursing piglets (Nielsen, 1983 reported by Straw, 1992). At a later stage (i.e. weaning period), the role of hygiene in relation to digestive disorders was emphasized (Madec *et al.*, 1998). These authors carried out a cohort study on 12,000 piglets (106 farms). Diarrhoea and mortality, together with the hygiene routines, were recorded daily. The odds that weaned piglets would be affected by enteric disorders, mainly due to enterotoxigenic *E. coli*, were 7.8 times higher in pigs subjected to poor hygienic conditions rather than to those of a high standard. This Odds Ratio was the second highest in the list of risk factors, just after aspects of feed intake. Other authors have stressed the importance of including hygiene in prevention programmes against *E. coli* diseases in the young pig (Fairbrother and Gyles, 2006). The faecal-oral transmission of pathogens is critical in enteric diseases in pigs at all physiological stages. This has been emphasized on diverse occasions for the growing-finishing phase when proliferative enteropathies, colonic spirochetosis and swine dysentery can occur. Herd management strategies, such as those aimed at reducing contact with slurry, have been suggested (Hampson and Duhamel, 2006). Some of the corresponding pathogens (e.g. *Brachyspira hyodysenteriae*) are relatively resistant in the pig house environment, particularly in faeces under moist conditions (Hampson *et al.*, 2006). In one study, *B. hyodysenteriae* survived for 10 days in soil kept at 10 °C but for 112 days in pure faeces (Boye *et al.*, 2001). Transmission of enteric pathogens between pens is much more likely to occur in buildings where there are open partitions or when excreta are drained through open channels between the pens.

In breeding sows, poor attention to cleanliness, especially of the hindquarters, was found to increase the risk of urogenital tract infections. Maintaining a high standard of hygiene is of paramount importance (Dee, 1992; Madec, 2009). Urinary tract infections, in particular, are hygiene-related and keeping the sows clean implies keeping the floors clean (Figure 17.3). Inadequate hygiene is mainly and most clearly connected to enteric and reproductive disorders. However the beneficial effects of ensuring high standards of hygiene have also been reported for respiratory diseases and leg problems (Hurnik *et al.*, 1994). In both cases the beneficial effect is due to cleaning which reduces the pressure exerted by potentially pathogenic micro-organisms, as illustrated in Figure 17.1. It was demonstrated that pigs could become infected with *Salmonella* during a very short stay on a contaminated surface, e.g. during lairage at the slaughterhouse (Hurd *et al.*, 2002). This conclusion was confirmed in a recent Swedish experiment (Osterberg *et al.*, 2010). Naïve pigs were placed in a room that had previously housed *Salmonella*-infected and faecal shedding pigs. The room was scraped but not washed between the two subsequent groups of pigs. Most of the naïve pigs became infected as a result of residual contamination of the environment. In pig farming, as with other livestock, surface cleaning and disinfection needs to be considered as an essential and highly effective means of reducing the pathogen load in buildings (Morgan-Jones, 1987).



## 17. Aiming at building cleanliness to keep livestock healthy



Figure 17.3. Providing poor hygiene is taking the risk of health disorders such as uro-genital tract problems in sows kept confined. The physical properties of the floor combined with appropriate husbandry should avoid exposure to humid and dirty floors (photo: Anses, Ploufragan).

Boar taint is another aspect connected with cleanliness in pigs. Boars accumulate various substances (predominantly androstenone and skatole) in their fatty tissue during sexual development and when mature, that are regarded as major contributors to boar taint. This is distinctive and unpleasant, and is perceived through a sensory combination of odour, flavour and taste in pork and pork products during cooking and eating (EFSA, 2005). If the floor of the piggery is partly or totally solid, the excretions (faeces and urine) on the solid area increase significantly with temperature (Huynh *et al.*, 2005) and the area gets dirty. Pigs are strongly motivated to wallow when subjected to such conditions. A positive relationship was found between the dirtiness of slaughter pigs and the skatole levels in their subcutaneous fat (Hansen *et al.*, 1995). Keeping pigs completely clean during the last week before slaughter was found to be effective in reducing skatole and indole levels at slaughter.

The practical options contributing to cleanliness in pigs and hygiene maintenance in their housing can be divided into two groups: those associated with building design and those related to building usage.

Slatted floors in the dunging area of farrowing pens were compared with solid floors in Sweden (Rantzer and Svendsen, 2001a). A total of 201 litters were studied. Pen hygiene was significantly better on slatted (i.e. perforated) floors. A larger amount of environmental bacteria was detected on the surfaces of pens with solid floors as well as a higher total mortality in nursing piglets. On the other hand, no effect was found on the daily weight gain of survivors until weaning. In another experiment involving the same floor design, the researchers investigated what happened during



the month following weaning and again found that a slatted floor improved pen cleanliness and resulted in a lower infection pressure than a solid floor (Rantzer and Svendsen, 2001b). Morbidity due to diarrhoea was also reduced. In growing-finishing pigs raised on partially slatted or fully slatted floors in France, cleanliness was significantly better on the fully slatted floor (Courboulay *et al.*, 2003). A similar experiment in the Netherlands, but including different stocking densities, indicated that the number of dirty pens was higher on solid floors (Spoolder *et al.*, 2000). When the effect of zoning (i.e. floors of varying type and material) was tested in weaning and fattening pigs in Denmark, zoned pens were found to get dirtier (Damgaard *et al.*, 2006). In another experiment, groups of pregnant sows were kept in a building with an automatic feeding system on a fully slatted or partially slatted floor (58% of the solid surface), obtained by covering the slatted part. The soiled area of the floor and sow dirtiness were determined at regular intervals (Jegou *et al.*, 2005). As expected, a close correlation was found between sow dirtiness and floor dirtiness. The sows stayed much cleaner on a fully slatted floor, and chose a specific place for excretion and a well separated one for lying down and resting, even if there was no floor zonation. The conflicting results sometimes obtained for slatted floors can be due to the considerable variability in their design (e.g. slot width and shape) and physical quality (e.g. abrasiveness, roughness after numerous pressure washings), surface and edge deterioration after use (contact with urine). The need to design floors to protect the animal's feet was recognized a long time ago and cleanliness as well as abrasiveness and slipperiness were technical points emphasized at that time (Scott, 1985). They have still to be focused on (Figure 17.4).

Building management. Building design '*per se*' is of primary importance if the aim is to keep the buildings clean and thus the pigs clean. However when cleanliness is considered in terms of animal health, and even occupational health, hygiene considerations must include other elements of farm management such as the locations of farm buildings and their inter-connections, together with the equipment and its usage. There is little doubt that building design and management together lay the foundation for health and do so in the long term (Pedersen and Dahl, 1995).

The most appropriate technical option for maintaining health is batch farrowing combined with an all-in/all-out policy, as compared to continuous flow. With this system, the farmer decides on the time interval between groups of sows due to farrow as well as the approximate number of



Figure 17.4. Slatted concrete floors, when well designed, constructed and maintained are a good pavement for obtaining clean and healthy livestock (photo: Anses, Ploufragan).

## 17. Aiming at building cleanliness to keep livestock healthy

contemporary pigs expected to be born during the farrowing periods. The goal is to keep only those pigs born within a very narrow time window together in a room (or compartment) and to avoid mixing animals from other batches. The rooms (i.e. entire farrowing rooms, nursery rooms, growing-finishing rooms) are cleaned, washed and disinfected in-between the batches. These routines are performed on a regular basis (i.e. every 4 or 5 weeks for the farrowing rooms, depending on weaning age; every 7 weeks or so for the nursery rooms...). With the all-in/all-out system, the slurry under the slatted floor is also removed. Every piece of equipment in the room is cleaned and disinfected. The building is then allowed to dry out before the room is repopulated. Farm managers need to be aware that the dirty surfaces in contact with animals in the buildings may not be the only sources of infection. Enteric pathogens have been isolated from mice and rats captured in piggeries which means that hygiene routines cannot be restricted to cleaning the surfaces *'per se'* (Hampson *et al.*, 2006). Houseflies were also found to be vehicles for pathogens especially viruses (Ahmad *et al.*, 2007; Blunt *et al.*, 2011; Förster *et al.*, 2009; Otake *et al.*, 2003). Building cleanliness means controlling these sources of pathogens as well and definitely constitutes a major aspect of internal biosecurity. Reducing the concentration of pathogenic agents in the pig's environment between occupancy periods also reduces the challenges of these agents to the next group to reside in the room (Curtis and Backstrom, 1992). A true sanitation break can be accomplished only when the room is completely empty. The improvement obtained by adopting such a policy was soon reported in suckling piglets (Pepper and Taylor, 1997, Table 17.3). Adopting such a herd management system with strict age-segregated rearing also had a beneficial effect on minimizing the incidence of respiratory disorders (Beskow *et al.*, 2001), thus corroborating earlier suggestions (Done *et al.*, 1991). Pigs kept in a dirty environment had a lower growth rate (Lee *et al.*, 1997). Opportunities for assessing hygiene in organic pig farming were investigated in Finland, along with feasibility studies (Siekkinen *et al.*, 2006). A method was developed that showed real potential for practical use in diverse production systems and not only on organic farms.

### 17.2.4 Cleanliness and health in other farm animals

As in dairy cattle and pigs, improved farm hygiene also leads to a beneficial return in other species. In poultry, *Salmonella* contamination is a major issue, both in laying hens and broilers. The impact of infection essentially concerns food safety, i.e. veterinary public health. The type

Table 17.3. Piglet performance before and after the adoption of a strict all-in/all out and related hygiene procedure (from Pepper and Taylor, 1977).

	30 litters preceding the break	First batch after break (30 litters)	Second batch after break (30 litters)
Average litter size (at 8 weeks)	7.6	8.2	8
Average pig weight at weaning (8 weeks)	11.2	13.9	12.3
Mortality (% at 8 weeks)	18.3	13.7	12.2

## F. Madec

of housing (e.g. flooring) clearly affects the ease with which adequate cleaning and disinfection can be carried out (Valancony *et al.*, 2001). In this respect *Salmonella* contamination was shown to persist for longer when subsequent flocks were housed in cages than when raised on-floor (Davies and Breslin, 2003). *Salmonella* contamination of the previous flock was found to be a source of contamination for subsequent flocks on broiler farms (Angen *et al.*, 1996), which demonstrates the primary importance of adequate cleaning and disinfection between flocks. In a study involving more than 500 flocks of laying hens in France, 51.9% of flocks reared on-floor and detected positive for *Salmonella enteritidis*, were located on farms where the previous flocks had also been positive (Huneau-Salaün *et al.*, 2009). Implementing high standards of cleaning and disinfection on a routine basis can be difficult (Davies and Breslin, 2003). Problems were encountered in attempts to eliminate *Campylobacter jejuni* on surfaces particularly at the slaughterhouse (Peyrat *et al.*, 2008).

Rearing systems for veal calves were compared in the UK with specific focus on evaluating dirtiness (Webster *et al.*, 1985). The farms were visited regularly. The number of calves showing evidence of muck on the coat was recorded and scored according to a three-point scale of severity for 6 body sites. Veal calves in crates tended to be caked with faeces around the legs and hindquarters. 20% of the calves raised in crates had abraded, bruised or swollen knees and 3% were diagnosed as having serious injuries. Calves raised in strawed yards were also caked with dirt and faeces and this was attributed to unrestricted access to a liquid diet and high stocking density. Hence, cleanliness was influenced by both the design and management of the buildings.

Various recommendations were issued following the fatal cases of food poisoning due to *E. coli* O157: H7 that occurred in the UK in the middle of 1990s (Pennington, 1997). These recommendations included the need to present clean cattle for slaughter. Although many factors affect cleanliness in cattle, the floor is by far the most important (Steen and O'Hagan, 1998). Beef cleanliness was examined on different types of floor in Northern Ireland (Lowe *et al.*, 2001). No clear differences were found in the study as the results tended to change over the survey period (Table 17.4). The role of the inclination of the lying area on cleanliness was investigated in fattening bulls raised in cubicles (Schulze-Westerath *et al.*, 2006). In this experiment the degree of dirtiness of the animals remained low and no clear influence of inclination was found. However the rear part of the lying area became wetter as the slope decreased. An inclination of

Table 17.4. The effect of floor type on cleanliness scores of beef cattle in years 1 and 2 (Lowe *et al.*, 2001).

	Floor type				SEM	Significance
	Slats	Mats	Strips	Straw		
Year 1: cleanliness score <sup>1</sup>	64.3 <sup>a</sup>	71.1 <sup>a</sup>	–	44.8 <sup>b</sup>	4.27	***
Year 2: cleanliness score <sup>1</sup>	36.5 <sup>ab</sup>	42.7 <sup>b</sup>	33.7 <sup>a</sup>	33 <sup>a</sup>	2.39	*

<sup>1</sup> Score scale: Scott and Kelly, 1989.

<sup>a,b</sup> Means on the same row with the same superscript do not differ significantly ( $P>0.05$ ).

## 17. Aiming at building cleanliness to keep livestock healthy

5% was considered optimal. The same team investigated the effect of flooring on leg lesions and cleanliness in bulls raised on farms. Seventeen farms were involved (623 bulls). The animals remained fairly clean throughout the survey period and no clear relationship between cleanliness and leg lesions could be detected (Schulze-Westerath *et al.*, 2007). Once again, this shows not only that the general floor type needs to be taken into consideration with regard to health but also the physical characteristics of the floors (i.e. slot width, smoothness, abrasiveness, etc.) and the way they are used on the farms.

### 17.3 Cleaning-disinfection of livestock buildings

#### 17.3.1 Introduction

As indicated above, infection control and basic hygiene should be at the heart of good husbandry. However it is apparent from our daily observations that current trends in cost containment and/or workload limitation eventually result in hygiene deficiencies. The permanent economic constraints aimed to reduce production costs tend to encourage the design of lower-cost buildings where hygiene maintenance is made more difficult. Designers of livestock buildings need to take all components into account, particularly the major role of animal housing in long term health maintenance. In this respect the ease with which the floors can be kept clean during the period of occupancy is of utmost importance. Nevertheless, in intensive confined livestock farming, particularly when an age-segregated, all-in/all-out system is implemented, cleaning/disinfection of the barns must be followed by a down time period between each group of animals. The procedure may vary depending on the production type and the type of building, but the general principles remain the same and the first step is always cleaning (Grow, 1995). Special care is obviously necessary in the case of outbreaks of notifiable diseases (e.g. FMD, CSF, etc.) but only common farming situations will be dealt with here. The appropriate information concerning notifiable diseases can be found at the OIE website ([www.oie.int](http://www.oie.int)).

#### 17.3.2 Cleaning – the most critical step

Before starting with wet cleaning operations, the room (compartment) needs to be emptied. The animals should be removed as well as the manure or slurry in the pit below the slatted floors (all-in/all-out management). Ventilation systems and other electrical supplies must be turned off. Some of the internal equipment will have to be dismantled in order to be cleaned properly and this must be done first. Miscellaneous transportable equipment (e.g. feed dispensers for nursing piglets, etc.) should be taken out of the room and stacked in a special area where cleaning is facilitated. Inside the room, dust and other dirt should be brushed, swept, vacuumed or wiped from ceilings, fan parts, air inlets, etc. In poultry houses it is advisable to remove all dust and egg debris from the egg conveyors. The egg belts '*per se*' also need to be removed to facilitate cleaning. This preliminary stage has been called 'dry cleaning' (Böhm, 1998). Since pressure water will be used in a later step, the place must be made safe (e.g. electric systems must be protected) and the people in charge of cleaning-disinfection should be aware of the risks and wear appropriate protective clothes or equipment.

The surfaces found in livestock buildings vary considerably in their ability to accumulate dust and dirt, and the ease with which they can be cleaned (Sandahl, 1975). Wet cleaning should start soon after removal of the animals to prevent the dirt from drying and should begin with soaking. The goal is to soften the dirt and make it easier to remove from the surfaces during the following step. Detergents can be used to help loosen the dirt either at the start of soaking or just at the end of this phase. It should be remembered that detergents act on dirt whereas disinfectants focus on the micro-organisms. One of the first detergents to be made was soap. The chemical components currently used as detergents can be roughly categorized into alkaline (pH>10), acid (pH<4) or neutral products (Mounier *et al.*, 2009). Soaking should not require too much water. The recommended amounts range from 1.5 to 6 l/m<sup>2</sup>, strongly depending on the target situation (i.e. surface roughness, level and type of dirtiness (e.g. more or less sticky faeces)). The recommended duration of soaking will also vary (from about 3 hours to sequences of successive moistening over a 12 hour period or so, using automatic sprinklers).

The next step is washing. The goal is to remove all debris and dirt until the surfaces are visibly clean (Böhm, 1998). Disinfectants are only effective when they come into direct contact with pathogens which demonstrates the importance of removing organic matter and other debris that could protect micro-organisms. Some disinfectants (e.g. sodium hypochlorite) are inactivated by organic matter. The most effective way of cleaning surfaces is to use pressure water. The amount of pressure to use and the type of equipment (shape of the nozzle) is open to discussion. Medium (40 bars) to high pressure (80 bars) is generally recommended. The most important point is to clean the surfaces adequately but to avoid wasting water. Amounts ranging from 20 to 50 l/m<sup>2</sup> have been reported, again depending on local circumstances (e.g. presence of bars, corners, angles, difficult areas to reach, etc.). Cleaning with warm water (e.g. 40 °C), when available, is most effective (Böhm, 1998). After washing, a final rinse under low pressure is recommended to obtain a clean room and eliminate residues of the cleaning products. Detergent residues can interfere with some disinfectants. However, since high pressure washing generates aerosols, the author recommends waiting for about 2 hours after the end of pressure washing, before rinsing, for the aerosols to settle. A specific comment needs to be made about using high pressure and chemicals on certain surfaces such as concrete floors (e.g. slatted floors). In pig houses, resistance of the floor to degradation mainly depends on the composition of the material (i.e. concrete quality) and the type of feed supply (wet vs. dry) (De Belie, 1997). However floor degradation due to unnecessary use of high pressure, should not be overlooked.

Cleaning and disinfection are working steps in animal husbandry which cannot be separated from each other without loss of effectiveness (Böhm, 1998). Chemical disinfectants should be mixed with water in the recommended concentrations, at the correct temperature, applied properly and handled with care (Grow, 1995). The manufacturer's guidelines should clearly describe how to proceed. The disinfection personnel should wear waterproof protective clothing, gloves, rubber boots and a face mask. On a routine basis, the choice of disinfectant will depend on the surfaces to be cleaned (some disinfectants are corrosive) and environmental factors (e.g. water pH and composition such as hardness). Any commercial products need to have received official approval. The general properties of common families of disinfectants are given in Table 17.5 (FAO, 2010). The disinfection procedure should ensure that all the surfaces are thoroughly treated and that the disinfectant is given enough exposure time to exert its properties efficiently. Disinfection can be

## 17. Aiming at building cleanliness to keep livestock healthy

Table 17.5. General properties of common disinfectants (FAO, 2010). Cidal = effective (e.g. bactericidal).

Disinfectant	Bacteria	Virus	Fungi	Spores	Mycobacterium	Human health risk
Alcohol	C	C	C	C	I	inflammable, strong odour
Formaldehyde	C	C	C	C	C	irritating, explosive, carcinogen, allergen
Glutaraldehyde	C	C	C	C	C	allergen
Halogens: chlorine, bromine, iodine	C	C	C	C	C in alcohol	irritating, reactive with other chemicals
Phenols	C	C	C	I	C	toxic, absorbed through the skin, bio-accumulative
Quaternary ammoniums	C	C/L		I	I	
Peroxides	C	C	C	C	C	explosive, irritating
Acids	C	C	C			corrosive

C=cidal; L=lipophylic; I=inhibitory.

performed in different ways e.g. by pressure cleaner equipped with a special 'disinfection nozzle'. There are also power sprayers and foam-delivery machines (e.g. hydrofoamers). The latter system has the advantage of extending the duration of exposure of the surfaces (especially vertical ones) to the disinfectant. It also clearly indicates to the operator which places are being treated (Dee *et al.*, 2006). Feeders and drinkers need to be rinsed to remove any residual disinfectant. The room must then be left to dry. A down-time period of at least 4 days is recommended to allow complete drying and thereby reduce the risk of residual contamination (Böhm, 1998).

### *How to evaluate the efficacy of the cleaning-disinfection process?*

There seems to be an overall relationship between the visual assessment of cleanliness and the efficacy of the process. However a more objective assessment may be useful from time to time to test the appropriateness of the hygiene routines and possibly amend the procedure where necessary.

Complete removal of all micro-organisms from the surfaces in livestock buildings is impossible and the aim is therefore to reduce their amounts (Böhm, 1998). The procedure adopted should avoid any residual contamination with pathogens that might compromise the subsequent health of incoming livestock after repopulation of the building. This is obviously especially important when the premises need to be cleaned following the outbreak of a notifiable disease. On the farm, as in food industry factories (e.g. meat, dairy), care should be taken to select suitable surface

## F. Madec

materials as well as cleaning and disinfection products to minimize the presence of biofilms on surfaces (Knight and Craven, 2010; Small *et al.*, 2007).

The efficacy of the cleaning-disinfection sequence of operations is commonly evaluated from bacterial counts on the surfaces following drying (i.e. before the buildings are used again). Surface samples can be collected by means of agar contact plates (e.g. Rodac plates), cotton swabs, gauze surgical swabs, gauze socks or sponges (Beloil *et al.*, 2004; Kihlstrom *et al.*, 2001; Madec *et al.*, 1999; Schmidt *et al.*, 2004; Small *et al.*, 2007; Wales *et al.*, 2006). The media used to count bacteria in the laboratory may also vary depending on the purpose of sampling, i.e. targeting a specific pathogen such as *Salmonella*, or a broad assessment of residual bacterial contamination. In the latter case several media are often used in parallel since they can give very different results (e.g. PCA or TSA for aerobic bacteria, VRBG for enterobacteriaceae). When agar contact plates are used, the physical properties of the medium are crucial to ensure a good and standardized impression on the surface. Figure 17.5 shows the results obtained when a nursery was sampled on 129 pig farms (n=24 agar plates per room). A wide range of factors was detected which were supposed to explain the results (Madec *et al.*, 1999). When the aim is to assess residual viral contamination, the surfaces can be swabbed and the swabs then subjected to PCRs for targeted nucleotide sequences. This procedure was used to assess PRRS virus residual contamination of transport vehicles in the USA (Dee *et al.*, 2006). The positive samples were evaluated for viable PRRS virus in a bioassay (i.e. involving animals).

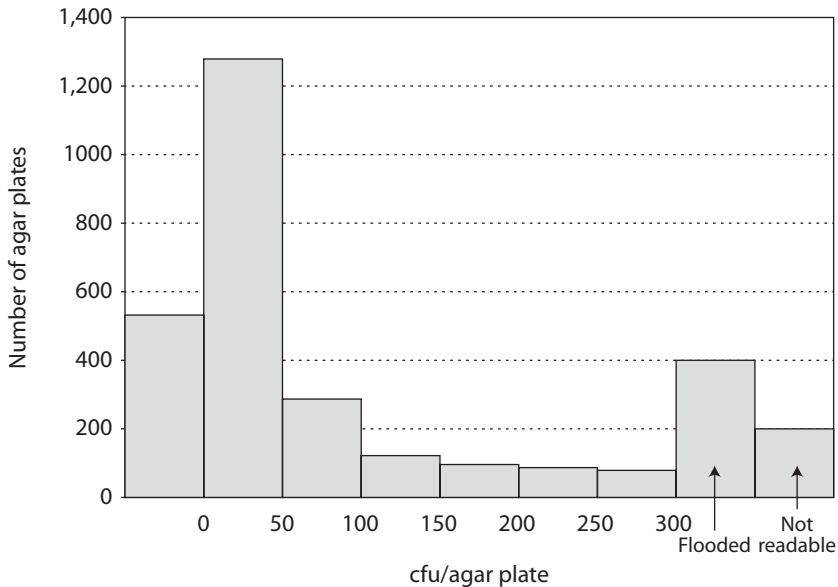

Figure 17.5. Overall bacteriological counts obtained on the surfaces of pig nurseries (floor + pen partitions) Agar contact plates (VRBG medium): number of plates: 3,045; number of farms: 129; median (colony forming units): 20 (Madec *et al.*, 1999).



### 17.4 Conclusion

Livestock production has evolved considerably over the last few decades. Large communities of animals are raised together and often confined to buildings. Health maintenance presents a challenge and the most effective approach is to ensure good hygiene by providing clean accommodation. Although this seems mere common sense to many, daily on-farm observations have revealed that cleanliness is overlooked far too often and that there is still a considerable room for improvement. Animal cleanliness is directly related to the cleanliness of the floors in the housing units. Moreover cleanliness provides a useful indication of the degree of challenge to which the animals are exposed. The notion of infection pressure or microbial load needs to be considered when designing buildings as well as discussing herd management. This pressure determines, at least in part, the risk of occurrence of so-called multifactorial or production diseases and their degree of severity. For these reasons, cleaning operations and hygiene routines in livestock buildings must not be considered as 'minor' tasks. They need to be promoted to the same rank as other routine activities that are jointly aimed at ensuring the health and welfare of farm animals.

### References

- Ahmad, A., Nagaraja, T.G. and Zurek, L., 2007. Transmission of *Escherichia coli* O157: H7 to cattle by house flies. *Preventive Veterinary Medicine* 80: 74-81.
- Aland, A., Lidfors, L. and Ekesbo, I., 2009. Impact of elastic stall partitions on tied dairy cows' behaviour and stall cleanliness. *Preventive Veterinary Medicine* 92: 154-157.
- Amass, S.F., Mason, P.W., Pacheco, J.M., Miller, C.A., Ramirez, A., Clark, L.K., Ragland, D., Schneider, J.L. and Kenyon, S.J., 2004. Procedures for preventing transmission of foot-and-mouth disease virus (O/TAW/97) by people. *Veterinary Microbiology* 103: 143-149.
- Amass, S.F. and Baysinger, A., 2006. Swine disease transmission and prevention. In: Straw, B.E., Zimmerman, J.J., D'Allaire, S. and Taylor, D.J. (eds.) *Diseases of swine*, 9<sup>th</sup> edition. Blackwell Publishing, Oxford, UK, pp. 1075-1098.
- Angen, O., Skov, M.N., Chriél, M., Agger, J.F. and Bisgaard, M., 1996. A retrospective study on salmonella infection in Danish broiler flocks. *Preventive Veterinary Medicine* 26: 223-237.
- Barkema, H.W., Schukken, Y.H., Lam, T.J., Beiboer, M.L., Benedictus, G. and Brand, A., 1998. Management practices associated with low, medium, and high somatic cell counts in bulk milk. *Journal of Dairy Science* 81: 1917-1927.
- Barker, Z.E., Leach, K.A., Whay, H.R., Bell, N.J. and Main, D.C.J., 2010. Assessment of lameness prevalence and associated risk factors in dairy herds in England and Wales. *Journal of Dairy Science* 93: 932-941.
- Beloil, P.A., Chauvin, C., Proux, K., Madec, F., Fravallo, P. and Alioum, A., 2004. Impact of the *Salmonella* status of market-age pigs and the pre-slaughter process on *Salmonella* caecal contamination at slaughter. *Veterinary Research* 35: 513-530.
- Bernardi, F., Fregonesi, J., Winckler, C., Veira, D.M., Von Keyserlingk, M.A.G. and Weary, D.M., 2009. The stall-design paradox: neck rails increase lameness but improve udder and stall hygiene. *Journal of Dairy Science* 92: 3074-3080.
- Berry, S.L., 2006. Infectious diseases of the bovine claw. Proceedings of the 14<sup>th</sup> International symposium on lameness in ruminants. Uruguay, November 8-11, pp. 52-57.



## F. Madec

- Beskow, P., Norqvist, N. and Wallgren, P., 2001. Follow-up of measurements aimed to decrease respiratory disorders in slaughter pigs. *Svensk Veterinärtidning* 53: 673-685.
- Blunt, R., McOrist, S., McKillen, J., McNair, I., Jiang, T. and Mellits, K., 2011. House fly vector for porcine circovirus 2b on commercial pig farms. *Veterinary Microbiology* 149: 452-455.
- Böhm, R., 1998. Disinfection and hygiene in the veterinary field and disinfection of animal houses and transport vehicles. *International Biodeterioration & Biodegradation* 41: 217-224.
- Boon, C.R. and Wray, C., 1989. Building design in relation to the control of diseases of intensively housed livestock. *Journal of Agricultural Engineering Research* 43: 149-161.
- Boye, M., Baloda, S.B., Leser, T.D. and Moller, K., 2001. Survival of *Brachyspira hyodysenteriae* and *B. pilosicoli* in terrestrial microcosms. *Veterinary Microbiology* 81: 33-40.
- Bracke, M.B.M., 2007. Multifactorial testing of enrichment criteria: pigs 'demand' hygiene and destructibility more than sound. *Applied Animal Behaviour Science* 107: 218-232.
- Chassagne, M., Barnouin, J. and Le Guenic, M., 2005. Expert assessment study of milking and hygiene practices characterizing very low somatic cell score herds in France. *Journal of Dairy Science* 88: 1909-1916.
- Cook, N.B. and Nordlund, K.V., 2009. The influence of the environment on dairy cow behavior, claw health and herd lameness dynamics. *The Veterinary Journal* 179: 360-369.
- Courboulay, V., Bregeon, A., Massabie, P. and Meunier-Salaün, M.C., 2003. Types of floors for fattening pigs. *Techni-porc* 26: 33-37.
- Curtis, S.E. and Backstrom, L. 1992. Housing and environmental influences on production. In: Leman, A.D., Straw, B.E., Mengeling, W.L., D'Allaire, S. and Taylor, D.J. (eds.) *Diseases of Swine*, 7<sup>th</sup> edition, Iowa State University Press, Ames, IA, USA, pp. 884-900.
- Damgaard, B.M., Studnitz, M., Nielsen, J., Moustsen, V.A., Jørgensen, E. and Jensen, K.H., 2006. The effects of zonation of the pen and grouping in intact litters on use of pen, immune competence and health of pigs. *Livestock Science* 104: 203-216.
- Dancer, S.J., 2004. How do we assess hospital cleaning? A proposal for microbiological standards for surface hygiene in hospitals. *Journal of Hospital Infection* 56: 10-15.
- Davies, R. and Breslin, M., 2003. Observations on *Salmonella* contamination of commercial laying farms before and after cleaning and disinfection. *Veterinary Record* 152: 283-287.
- De Belie, N., 1997. A survey on concrete floors in pig houses and their degradation. *Journal of Agricultural Engineering Research* 66: 151-156.
- Dee, S.A., 1992. Porcine urogenital disease. In: Tubbs, R.C. and Leman, A.D. (eds.) *The veterinary clinics of North America: swine reproduction*. W.B. Saunders, Philadelphia, PA, USA, pp. 641-660.
- Dee, S.A., Joo, H.S., Polson, D.D., Park, B.K., Pijoan, C., Molitor, T.W., Collins, J.E. and King V., 1997. Evaluation of the effects of nursery depopulation on the persistence of porcine reproductive and respiratory syndrome virus and the productivity of 34 farms. *Veterinary Record* 140: 247-248.
- Dee, S.A., Deen, J. and Pijoan, C., 2006. Evaluation of an industry-based sanitation protocol for full-size transport vehicles contaminated with porcine reproductive and respiratory syndrome virus. *Journal of Swine Health and Production* 14: 307-311.
- DeHart, D.A., Natzke, R.P. and Oltenacu, P.A., 1976. Effect of coliform challenge at milking time on new udder infections. *Journal of Dairy Science* 59: 1124-1130.
- Diesch, S.L., 1996. Teaching methodologies for animal hygiene. *Proceedings X Seminario educacion e investigacion en higiene animal, America y Europa: dos aproximaciones*, October 29-31, 1996, pp. 37-40.

## 17. Aiming at building cleanliness to keep livestock healthy

- Dohmen, W., Neijenhuis, F. and Hogeveen, H., 2010. Relationship between udder health and hygiene on farms with an automatic milking system. *Journal of Dairy Science* 93: 4019-4033.
- Done, S.H., 1991. Environmental factors affecting the severity of pneumonia in pigs. *Veterinary Record* 128: 582-586.
- EFSA, 2005. The welfare of weaners and rearing pigs: effects of different space allowances and floor types. *Annex to EFSA Journal* 268: 1-19.
- Ekesbo, I., 1996. Disease incidence in tied and loose housed dairy cattle. *Acta Agriculturae Scandinavia, Supplement* 15: 1-74.
- Fairbrother, J.M. and Gyles, C.L., 2006. *Escherichia coli* infections. In: Straw, B.E., Zimmerman, J.J., D'Allaire, S. and Taylor, D.J. (eds.) *Diseases of swine*, 9<sup>th</sup> edition. Blackwell Publishing, Oxford, UK, p. 639-674.
- FAO/OIE/WB, 2010. Good practices for biosecurity in the pig sector. Issues and options in developing and transition countries. *FAO paper no. 169*, 41 pp.
- Faye, B. and Barnouin, J., 1985. Objectivation de l'état de propreté des vaches laitières. L'indice de propreté. *Bulletin Technique, CRZV Theix, INRA*, 59: 61-67.
- Förster, M., Klimpel, S. and Sievert, K., 2009. The house fly (*Musca domestica*) as a potential vector of metazoan parasites caught in a pig-pen in Germany. *Veterinary Parasitology* 160: 163-167.
- Fremantle, F.E., 1929. The health and cleanliness council. *The Lancet* 30: 695-696.
- Fulwider, W.K., Grandin, T., Garrick, D.J., Engle, T.E., Lamm, W.D., Dalsted, N.L. and Rollin, B.E., 2007. Influence of free-stall base on tarsal joint lesions and hygiene in dairy cows. *Journal of Dairy Science* 90: 3559-3566.
- Galton, D.M., Adkinson, R.W., Thomas, C.V. and Smith, T.W., 1982. Effects of premilking udder preparation on environmental bacterial contamination of milk. *Journal of Dairy Science* 65: 1540-1543.
- Greenough, P.R. 1997. *Lameness in cattle*, 3<sup>rd</sup> edition. W.B. Saunders Company, Philadelphia, PA, USA, 277 pp.
- Grow, A.G., 1995. Writing guidelines to require disinfection. *Revue Scientifique et Technique de l'Office International des Epizooties* 14: 469-477.
- Haas, B., Ahl, R., Böhm, R. and Strauch, D., 1995. Inactivation of viruses in liquid manure. *Revue scientifique et technique (International Office of Epizootics)* 14: 435-445.
- Hampson, D. and Duhamel, G.E., 2006. Porcine colonic spirochetosis/Intestinal spirochetosis. In: Straw, B.E., Zimmerman, J.J., D'Allaire, S. and Taylor, D.J. (eds.) *Diseases of swine*, 9<sup>th</sup> edition. Blackwell Publishing, Oxford, UK, pp. 755-767.
- Hampson, D.J., Fellström, C. and Thomson, J.R., 2006. Swine dysentery. In: Straw, B.E., Zimmerman, J.J., D'Allaire, S. and Taylor, D.J. (eds.) *Diseases of swine*, 9<sup>th</sup> edition. Blackwell Publishing, Oxford, UK, pp. 639-674.785-805.
- Hansen, L.L., Larsen, A.E. and Hansen-Moeller, J., 1995. Influence of keeping pigs heavily fouled with faeces plus urine on skatole and indole concentration (boar taint) in subcutaneous fat. *Acta Agriculturae Scandinavia, section A*, 45: 178-185.
- Haskell, M.J., Rennie, L.J., Howell, V.A., Bell, M.J. and Lawrence, A.B., 2006. Housing system, milk production and zero grazing effects on lameness and leg injury in dairy cows. *Journal of Dairy Science* 89: 4259-4266.
- Hogan, J. and Smith, K.L., 2003. Coliform mastitis. *Veterinary Research* 34: 507-519.
- Hughes, J., 2001. A system for assessing cow cleanliness. *In practice* 23: 517-524.
- Hultgren, J. and Bergsten, C., 2001. Effects of a rubber-slatted flooring system on cleanliness and foot health in tied dairy cows. *Preventive Veterinary Medicine* 52: 75-89.

## F. Madec

- Huneau-Salaün, A., Le Bouquin, S., Michel, V., Chemaly, M., Petetin, I., Rouxel, S., Lalande, F. and Rose, N., 2009. Risk factors for *Salmonella enterica* subsp. *enterica* contamination in 519 French laying hen flocks at the end of the laying period. *Preventive Veterinary Medicine* 89: 51-58.
- Hurd, H.S., McKean, J.D., Griffith, R.W., Wesley, I.V. and Rostagno, M.H., 2002. *Salmonella enterica* Infections in market swine with and without transport and holding. *Applied and Environmental Microbiology* 68: 2376-2381.
- Hurnik, D., Dohoo, I. R. and Bate, L. A., 1994. Types of farm management as risk factors for swine respiratory disease. *Preventive Veterinary Medicine* 20: 147-157.
- Huynh, T.T.T., Aarnink, A.J.A., Gerrits, W.J.J., Heetkamp, M.J.H., Canh, T.T., Spoolder, H.A.M., Kemp, B. and Verstegen, M.W.A., 2005. Thermal behaviour of growing pigs in response to high temperature and humidity. *Applied Animal Behaviour Science* 91: 1-16.
- Jansen, J., Van den Borne, B.H.P., Renes, R.J., Van Schaik, G., Lam, T.J.G.M. and Leeuwis, C., 2009. Explaining mastitis incidence in Dutch dairy farming: the influence of farmers' attitudes and behaviour. *Preventive Veterinary Medicine* 92: 210-223.
- Jasper, D.E., Dellinger, J.D. and Bushnell, R.B., 1975. Herd studies on coliform mastitis. *Journal of American Veterinary Medicine Association* 166: 778-780.
- Jegou, J.Y., Callarec, J., Dappelo, C., Guivarc'h, C., Quillien, J.P. and Ramonet, Y., 2005. Partially/fully slatted flooring: cleanliness of the floor and of the sows. *Chambre Agriculture Report*, Brittany, France, 21 pp.
- Kihlstrom, S.L., Morrow, W.E.M., Davies, P.R. and Luginbuhl, G.H., 2001. Assessing the progressive decontamination of farrowing crate floors by measuring the decrease in aerobic bacteria. *Journal of Swine Health and Production* 9: 65-69.
- Knight, G.C. and Craven, H.M., 2010. A model system for evaluating surface disinfection in dairy factory environments. *International Journal of Food Microbiology* 137: 161-167.
- Kossaibati, M.A. and Esslemont, R.J., 1997. The costs of production diseases in dairy herds in England. *The Veterinary Journal* 154: 41-51.
- Köster, G., Tenhagen, B.A. and Heuwieser, W., 2006. Factors associated with high milk test day somatic cell counts in large dairy herds in Brandenburg. I: Housing conditions. *Journal of Veterinary Medicine, series A* 53: 134-139.
- Lassen, J., Sandøe, P. and Forkman, B., 2006. Happy pigs are dirty! – conflicting perspectives on animal welfare. *Livestock Science* 103: 221-230.
- Lee, C., Downing, J.A., Giles, L.R., Collins, D.P., Bryden, W.L. and Wynn, P.C., 1997. Effect of group size and environment on weaner pig performance and plasma cortisol concentration. In: Cranwell, P.D. (ed.) *Manipulating pig production VI*. APSA, Werribee, Australia, p. 301.
- Lindquist, J.O., 1974. Animal health and environment in the production of fattening pigs. *Acta Veterinaria Scandinavica* 51: 1-78.
- Lowe, D.E., Steen, R.W.J., Beattie, V.E. and Moss, B.W., 2001. The effects of floor type systems on the performance, cleanliness, carcass composition and meat quality of housed finishing beef cattle. *Livestock Production Science* 69: 33-42.
- Madec, F., Bridoux, N., Bounnaix, S. and Jestin, A., 1998. Measurement of digestive disorders in the piglet at weaning and related risk factors. *Preventive Veterinary Medicine* 35: 53-72.
- Madec, F., Humbert, F., Salvat, G. and Maris, P., 1999. Measurement of the residual contamination of post-weaning facilities for pigs and related risk factors. *Journal of Veterinary Medicine* 46: 37-45.
- Madec, F., 2009. Reproductive disorders in pigs: a review on the crucial role of the environment. In: Aland, A. and Madec, F. (eds.) *Sustainable animal production*. Wageningen Academic Publishers, Wageningen, the Netherlands, pp. 215-238.

## 17. Aiming at building cleanliness to keep livestock healthy

- Madec, F. and Seegers, H., 2010. Epidemiology of infectious diseases in livestock raised in intensive farming systems. In: Lefevre, P.C., Blancou, J., Chermette, R. and Uilenberg, G. (eds.) Infectious and parasitic diseases of Livestock. vol. 1. Lavoisier, Paris, France, pp. 35-52.
- Magnusson, M., Herlin, A.H. and Ventorp, M., 2008. Effect of alley floor cleanliness on free-stall and udder hygiene. *Journal of Dairy Science* 91: 3927-3930.
- Manske, T., Hultgren, J. and Bergsten, C., 2002. The effect of claw trimming on the hoof health of Swedish dairy cattle. *Preventive Veterinary Medicine* 54: 113-129.
- Marti, O.G., Booram, C.V. and Hale, O.M., 1980. Survival of eggs and larvae of swine nematode parasites in aerobic and anaerobic waste treatment systems. *Journal of Environmental Quality* 9: 401-405.
- Morgan-Jones, S., 1987. Practical aspects of disinfection and infection control. In: Linton, A.H., Hugo, W.B. and Russell, A.D. (eds.) *Disinfection in veterinary and farm animal practice*. Blackwell Scientific Publications, Oxford, UK, pp. 144-167.
- Mounier, M., Pestourie, N., Ploy, M.C. and Denis, F., 2009. Detergents and disinfectants: medical applications (part 1). *Antibiotiques* 11: 177-184.
- Munoz, M.A., Bennett, G.J., Ahlström, C., Griffiths, H.M., Schukken, Y.H. and Zadoks, R.N., 2008. Cleanliness scores as indicator of *Klebsiella* exposure in dairy cows. *Journal of Dairy Science* 91: 3908-3916.
- Neave, F.K., Dodd, F.H. and Kingwill, R.G., 1966. A method of controlling udder disease. *Veterinary Record* 78: 521-525.
- Osterberg, J., Sternberg-Lewerin, S. and Wallgren, P., 2010. Direct and indirect transmission of four *Salmonella enterica* serotypes in pigs. *Acta Veterinaria Scandinavica* 52: 30-37.
- Otake, S., Dee, S.A., Rossow, K.D., Deen, J., Joo, H.S., Molitor, T.W. and Pijoan, C., 2002. Transmission of porcine reproductive and respiratory syndrome virus by fomites (boots and coveralls). *Journal of Swine Health and Production* 10: 59-65.
- Otake, S., Dee, S.A., Rossow, K.D., Moon, R.D., Trincado, C. and Pijoan, C., 2003. Transmission of porcine reproductive and respiratory syndrome virus by houseflies (*Musca domestica*). *Veterinary Record* 152: 73-76.
- Pedersen, B.K. and Dahl, J., 1995. Architecture lays the foundation for long-term herd health. *Pigs-Misset* 11: 44-45.
- Pennington, T.H., 1997. Report on the circumstances leading to the 1996 outbreak of infection with *Escherichia coli* O157 in Central Scotland, the implications for food safety and the lessons to be learned. The Stationery Office, London, UK.
- Pepper, T.A. and Taylor, D.J., 1977. Breeding record analysis in pig herds and its veterinary applications: experiences with a large commercial unit. *Veterinary Record* 101: 196-199.
- Peyrat, M.B., Soumet, C., Maris, P. and Sanders, P., 2008. Recovery of *Campylobacter jejuni* from surfaces of poultry slaughterhouses after cleaning and disinfection procedures: analysis of a potential source of carcass contamination. *International Journal of Food Microbiology* 124: 188-194.
- Rantzer, D. and Svendsen, J., 2001a. Slatted versus solid floors in the dung area of farrowing pens: effects on hygiene and pig performance, birth to weaning. *Acta Agriculturae Scandinavica. Section A* 51: 167-174.
- Rantzer, D. and Svendsen, J., 2001b. Slatted versus solid floors in the dung area: comparison of pig production system (moved versus not moved) and effects on hygiene and pig performance, weaning to four weeks after weaning. *Acta Agriculturae Scandinavica. Section A* 51: 175-183.
- Reneau, J.K., Seykora, A.J., Heins, B.J., Endres, M.I., Farnsworth, R.J. and Bey, R.F., 2005. Association between hygiene scores and somatic cell scores in dairy cattle. *Journal of the American Veterinary Medical Association* 227: 1297-1301.

## F. Madec

- Sandahl, A.M., 1975. Cleanability of building materials. *Farm Building Progress* 40: 19-21.
- Schmidt, P.L., O'Connor, A.M., McKean, J.D. and Hurd, H.S., 2004. The association between cleaning and disinfection of lairage pens and the prevalence of *Salmonella enterica* in swine at harvest. *Journal of Food Protection* 67: 1384-1388.
- Schreiner, D.A. and Ruegg, P.L., 2002. Effects of tail docking on milk quality and cow cleanliness. *Journal of Dairy Science* 85: 2503-2511.
- Schreiner, D.A. and Ruegg, P.L., 2003. Relationship between udder and leg hygiene scores and subclinical mastitis. *Journal of Dairy Science* 86: 3460-3465.
- Schulze-Westerath, H., Meier, T., Gygas, L., Wechsler, B. and Mayer, C., 2006. Effects of the inclination of the lying area in cubicles on the behaviour and dirtiness of fattening bulls. *Applied Animal Behaviour Science* 97: 122-133.
- Schulze-Westerath, H., Gygas, L., Mayer, C. and Wechsler, B., 2007. Leg lesions and cleanliness of finishing bulls kept in housing systems with different lying area surfaces. *The Veterinary Journal* 174: 77-85.
- Scott, G.B., 1985. Designing floors for animals' feet. *Farm building progress* 82: 27-32.
- Scott, G.B. and Kelly, M., 1989. Cattle cleanliness in different housing systems. *Farm building progress* 95: 21-24.
- Siekkinen, K.M., Nuotio, L., Ranta, J., Laukkanen, R., Hellström, S., Korkeala, H. and Majjala R., 2006. Assessing hygiene proficiency on organic and conventional pig farms regarding pork safety: a pilot study in Finland. *Livestock Science* 104: 193-202.
- Small, A., James, C., Purnell, G., Losito, P., James, S. and Buncic, S., 2007. An evaluation of simple cleaning methods that may be used in red meat abattoir lairages. *Meat Science* 75: 220-228.
- Spoolder, H.A.M., Edwards, S.A. and Corning, S., 2000. Legislative methods for specifying stocking density and consequences for the welfare of finishing pigs. *Livestock Production Science* 64: 167-173.
- Steen, R.W.J. and O'Hagan, J.C., 1998. Examination of factors affecting the dirtiness of housed cattle in Northern Ireland. Report to the Northern Ireland Research and Development Council, May 1998.
- Straw, B., 1992. Hygiene. Proceedings 'high health strategies', Minnesota swine conference for veterinarians, 19: 111-116.
- Tucker, C.B., Fraser, D. and Weary, D.M., 2001. Tail docking dairy cattle: effects on cow cleanliness and udder health. *Journal of Dairy Science* 84: 84-87.
- Valancony, H., Fournier, G., Drouin, P., Toux, J.Y. and Colin, P., 2001. Disinfection of cage layer houses contaminated with *Salmonella enteritidis*. *British Poultry Science* 42: 539-540.
- Van der Linde, C., De Jong, G., Koenen, E.P.C. and Eding, H., 2010. Claw health index for Dutch dairy cattle based on claw trimming and conformation data. *Journal of Dairy Science* 93: 4889-4891.
- Wales, A., Breslin, M. and Davies, R., 2006. Assessment of cleaning and disinfection in *Salmonella*-contaminated poultry layer houses using qualitative and semi-quantitative culture techniques. *Veterinary Microbiology* 116: 283-296.
- Webster, A.J., Saville, C., Church, B.M., Gnanasakthy, A. and Moss, R., 1985. Some effects of different rearing systems on health, cleanliness and injury in calves. *British Veterinary Journal* 141: 472-483.
- Zurbrigg, K., Kelton, D., Anderson, N. and Millman, S., 2005. Stall dimensions and the prevalence of lameness, injury, and cleanliness on 317 tie-stall dairy farms in Ontario. *Canadian Veterinary Journal* 46: 902-909.

## 18. Practical evaluation of cleaning methods that could be implemented in livestock buildings

T. Banhazi<sup>1</sup> and B. Santhanam<sup>2</sup>

<sup>1</sup>National Centre for Engineering in Agriculture (NCEA), University of Southern Queensland, West Street, Toowoomba, QLD 4530, Australia; <sup>2</sup>Livestock Systems Alliance, South Australian Research and Development Institute, Roseworthy Campus, Adelaide University, Roseworthy, SA 5371; [thomas.banhazi@usq.edu.au](mailto:thomas.banhazi@usq.edu.au)

### Abstract

A number of studies have demonstrated improved production efficiency and reduced respiratory problems in pigs reared in a clean building. There are a limited number of investigations in the literature that specifically evaluate different cleaning methods and their efficiency in reducing bacterial load on floor surfaces in livestock buildings. Studies were therefore initiated to assess cleaning procedures and surface hygiene improvement techniques, to examine if animal welfare could be improved and farm productivity maintained. As part of this study, controlled experiments were implemented to assess the effects of different cleaning methods on the resultant microbiological load of floor surfaces. The experiments clearly demonstrated the benefits of specific cleaning practices. The utilisation of degreasers and flaming of pen floors proved to be the most beneficial practices both on-farm and in laboratory settings.

**Keywords:** hygiene, disinfection, building management, pollutants

### 18.1 Introduction

One of the aims of any livestock production system is to minimise the prevalence of diseases and their impact on the herd, thus improving animal welfare and health as well as the health of stockpersons working in the system. Hence, there is need to improve livestock management practices, as well as housing systems, to enhance the physical environment of livestock buildings including hygiene levels.

### 18.2 Brief literature review

There have been many studies in Australia on air hygiene in livestock buildings (Banhazi *et al.*, 2008a,b,c,d,e). Evidence for the harmful effects of poor air quality on animal and human health has been demonstrated over the last 15 years (Banhazi *et al.*, 2009a,b; Cargill *et al.*, 1996). Epidemiological studies provided strong field evidence for the negative effects of poor air quality on the incidence and severity of respiratory diseases in pigs such as pleurisy (Robertson *et al.*, 1990; Skirrow *et al.*, 1995). Poor air quality in piggery buildings has also been associated with health problems in farm workers (Donham *et al.*, 1989, 1990, 2000), as well as pig health and growth rate problems (Lee *et al.*, 2005). Cleaning the facilities between batches of pigs is suggested as one method of improving air quality. For example, one of the benefits of applying all-in/all-out (AIAO) management in pig facilities is the extra 'pig free' time gained, which can be allocated



for thorough cleaning between batches (Cargill and Banhazi, 1998). Dirty pigs and pens are one of the major sources of respiratory dust, airborne bacteria and ammonia (Banhazi *et al.*, 2008d; Takai *et al.*, 1998). The faecal material smeared onto pigs and pens dries quickly, shedding micro-organisms, producing ammonia and very fine particles of dried faecal material, which stays airborne for long periods of time. Pen fouling causes extra labour for cleaning, increases the risk of health problems and increases the emission of ammonia to the environment (Banhazi and Cargill, 1997; Banhazi *et al.*, 2002).

However there are few investigations in the literature that specifically examine the efficacy of cleaning in an intensive livestock building and its effects on surface hygiene. Hygiene in livestock buildings is often less than satisfactory and potentially poses a constraint to improved production efficiency in intensive animal husbandry systems (Wathes, 1994). All surfaces within livestock buildings may harbour thriving populations of micro-organisms (Wathes, 1994). These micro-organisms flourish in the moist, warm microenvironments of bedding, particularly in the cracks and crevices of the building's structure and equipment, which are coated with a ready supply of nutrients made up of dust and manure. In the first few weeks after the weaning of pigs, problems often appear, manifested by poor feed intake, reduced growth, post-weaning diarrhoea and increased mortality. The effects of pen hygiene on production were evaluated in a study (Rantzer *et al.*, 1998). Mortality and morbidity among pigs raised in poor hygiene pens were higher than among the good hygiene pigs. After weaning, there were significantly more treatments given for *Escherichia coli*-associated post-weaning diarrhoea among the poor hygiene pigs. It is apparent that even a little difference in hygiene level may have a negative effect. The morbidity and mortality of the poor hygiene pigs was higher than the good hygiene pigs.

Normally a variety of physical cleaning processes are used prior to the use of chemical disinfectants. Piggery buildings are normally washed, by using either high-pressure cleaners or a low pressure hose followed by the application of a degreaser and/or a disinfection agent (Roelofs *et al.*, 1993). Surface hygiene may also be improved in buildings by applying some common-sense principles, such as the elimination of unnecessary horizontal and uneven vertical surfaces. Choice of building material may also have some significant effects on surface hygiene (De Belie *et al.*, 2000). Efficient and purposeful application of sanitation measures requires knowledge about the devitalisation effect of disinfectants on the target micro-organisms in their respective environment (Ondrasovic *et al.*, 2000). Equally important is the knowledge about the negative effects of disinfectants, such as toxicity, corrosive effects, irritant properties, and residual action. The development of new chemical disinfectants based on combination of various active ingredients with the addition of detergents or other potentiating substances increased considerably in recent years (Ondrasovic *et al.*, 2000).

In summary, cleaning standards and methods are increasingly being recognised as the most important components of good livestock management (Madec, 2013; Wathes, 1994). Often in the past, cleanliness and building hygiene issues have been under-estimated, but are emerging as one of the key factors affecting air quality, livestock health and production (Algers, 2000; Tielen, 2000). Despite the evidence presented by a number of authors (Duchaine *et al.*, 2000; Madec *et al.*, 1998; Rantzer and Svendsen, 2001), there are few investigations in the literature that specifically evaluated different cleaning methods and their efficiency in reducing bacterial

## 18. Practical evaluation of cleaning methods that could be implemented in livestock buildings

load on the floor surface in livestock buildings. Studies were therefore initiated and implemented at the University of Adelaide, Roseworthy Research Piggery with the aim of assessing cleaning methods and surface hygiene improvement techniques on-farm to ensure a high level of animal welfare and production.

### 18.3 Materials and methods

A number of controlled experiments were performed. The individual experiments were conducted on concrete 'hygiene-pavers' using pig manure to mimic pen fouling. The cleaning effect was evaluated based on reduction in the original bacterial load on the paver surface.

#### 18.3.1 Experimental tools – 'hygiene pavers'

To facilitate easy and controlled assessment of cleaning methods, a special experimental tool was developed. Concrete hygiene pavers (80×80×45 mm) were manufactured using Silica fume concrete to replicate the flooring material normally used in piggeries (Figure 18.1). This experimental tool enabled the researchers to use the required number of identical replicates for different treatments and also conduct the experiments under controlled conditions. However, it was also recognised that follow-up, farm based experiments had to be implemented to complement the results of these essentially laboratory based results. The results of the farm based experiments (validation trials) are also presented in this article.



Figure 18.1. Hygiene pavers are prepared for the experiments.



### **18.3.2 Microbiological tools**

In our experimental study, we used swabbing and plating technique to determine microbial loads before and after each cleaning method as a means of evaluating the cleaning efficiency. The technique involved swabbing the experimental surface with a 150 mm sterile cotton tipped swab (Rowe Scientific, South Australia) and transferring the swab onto a sterile Colombia horse blood agar (HBA) plate (Oxoid scientific, South Australia). HBA as a basal medium contains caesin hydrolysate supporting growth of large colonies of a broad range of Gram positive and Gram negative bacteria and a meat infusion with horse blood providing means for isolation of clinically significant pathogens such as *Staphylococcus*. After 48 hour incubation, any bacteria which have been transferred would grow and could then be counted. The Australian Standard Method suggests that 6 organisms/sq cm is an acceptable level of detection (NATA, 1992; ASM, 1996).

### **18.3.3 Manure preparation and application**

The 'hygiene-pavers' used during the study were individually pressure washed and disinfected with Virkon S® prior to use. Faecal material was collected from pig pens, mixed with water (1:1 volume ratio), homogenised and 150 g of mix was placed on each paver. The faecal material was evenly distributed over each paver with a spatula (Figure 18.2) and left for 8 h to mimic the natural baking effect occurring in pig pens and thus the hygienic condition of dirty pen floors. The coating with manure was the starting point of all experiments reported in this chapter. The hygiene pavers were then treated accordingly to the different experimental protocols to determine the efficacy of various cleaning methods.

### **18.3.4 Experimental design and cleaning methods**

The experiments conducted under laboratory conditions are listed in Table 18.1 and the cleaning methods implemented during the study are listed in Table 18. 2.

### **18.3.5 Sampling procedure**

After cleaning, the hygiene pavers were swab sampled using Perspex sheets with 4 cm<sup>2</sup> square windows (20×20 mm). Four replicates per hygiene paver were obtained to determine an accurate value for the residual viable bacterial load. The Perspex sheets were disinfected with 80% ethanol solution between each site (Figure 18.3). Aseptic swab was dipped into a sterile solution of 0.1% peptone water, the Perspex sheet was placed on the paver and the 4 cm<sup>2</sup> area was swabbed by firmly rolling the swab tip back and forth (Figure 18.4). The swab tip was then cut off into 0.1% peptone water and serially diluted four times (1:10<sup>4</sup>) to prepare an inoculums stock. Finally, 100 µl of the inoculum was uniformly spread onto a HBA plate and incubated at 37 °C for 48 h. The incubated plates were placed on a light box and the colony forming units were counted.

**18. Practical evaluation of cleaning methods that could be implemented in livestock buildings**



Figure 18.2. Application of pig manure on experimental pavers.

Table 18.1. Cleaning methods assessed during the study.

No	Experiment	Aims
1	Hosing vs. pressure washing	assess the efficacy of hosing compared to high-pressure washing
2	Hosing vs. degreasing	assess the efficacy of hosing compared to the utilisation of a degreaser product (Farm Mate™, Cyndan, Inc. Garland, USA)
3	Hosing vs. dry scrubbing	assess the effect of dry cleaning
4	Hosing vs. dry scrubbing and flaming	assess the effects of heat treatment (flaming)
5	Dry scrubbing vs. dry scrubbing and liming	assess the effects of using dry cleaning methods in combination with the application of lime-solution
6	Dry scrubbing and liming (summer vs. winter) over 24 h	assess potential climatic/temperature effects on the cleaning efficiency of using lime solution
7	Dry scrubbing and liming over varying periods (1, 24, 48 and 72 h)	assess the effects of using dry cleaning methods in a combination with the application of lime-solution and increased down-time

Table 18.2. Choice of cleaning methods applied in the study piggery.

Cleaning method	Description
Hosing	Individual hygiene pavers were hosed in a single direction using mains water for 10 sec aiming to remove visible particulates.
Pressure washing	Pressure washing was done using commercial pressure cleaner connected to mains water source. Hygiene pavers were hosed for 5 sec ensuring visual cleanliness of surface. The pressure hose was aimed at particulates in an unidirectional manner.
Degreasing	Hygiene pavers were hosed briefly for about 10 sec and followed by uniform coverage of degreasing agent. A commercial degreasing agent (Farm Mate™) diluted in water (1:3 volume ratio) was used. The degreaser was allowed to stand for 60 min before hosing briefly for an additional 10 sec.
Dry scrubbing	Heavy duty nylon brush was used to clean with hand pressure with an objective of removing visible particulates.
Liming	Hygiene pavers were evenly coated with 20 ml of builders lime slurry (11% w/v) ensuring full coverage of the paver surface.
Flaming	Hand held LPG gas burner was used in flaming the surface. Flame was moved across the surface from left to right of each paver ensuring an effective holding time of 5 sec during the process.
Temperature/seasonal effects	Hygiene pavers were dry cleaned, lime-treated and kept in an area artificially heated (mean temperature of 37 °C) or cooled (mean temperature of 8 °C) for 24 h before swabbed, mimicking summer/winter conditions.
Effects of increased down-time	Hygiene pavers were dry cleaned, lime-treated and sampled at different times (after <1 h, 24 h, 48 h and 72 h) to mimicking the effects of increased down-time.

### 18.3.6 On farm validation studies

A validation study was conducted on-farm in order to verify the efficacy of the cleaning techniques evaluated under ‘laboratory conditions’. The two best techniques were then selected for on-farm evaluation and two experiments were conducted at the University of Adelaide, Roseworthy Research Piggery weaner facility. As both experiments were conducted as a ‘before/after validation’ study; the untreated floor covered with dried faecal material was used as control. A total of 32 swab samples were collected during each experiment (16 control and 16 experimental samples) and sampling was done as described above in relation to the laboratory experiments.

**18. Practical evaluation of cleaning methods that could be implemented in livestock buildings**



*Figure 18.3. Perspex sampler sheet used during sample collection.*



*Figure 18.4. Taking swab samples from hygiene pavers.*

*Experiment one: dried untreated/dirty floor vs. degrease 1 hour and wash*

This experiment was done to validate the efficacy of using degreaser for 1 h and washing the floor after that. Exactly the same experimental procedure was followed as described in Table 18.1 and 18.2. Degreasing of floors was done with 1:3 diluted degreaser (Farm mate™) for 60 min. before hosing off the degreaser using mains water.

*Experiment two: dried untreated/dirty floor vs. dry scrubbing and flaming*

This experiment was done to validate the efficacy of dry scrubbing and flaming the floor. Flaming was done after dry scrubbing with a wire brush to remove visible particles as described in Table 18.1 and 18.2. Flaming was evenly conducted over the surface to ensure a minimum of 5 sec contact time.

### **18.3.7 Statistical methods**

Statistical evaluation of the results were undertaken using one-way ANOVA (StatSoft, 2001) as the experimental and control hygiene pavers were under exactly the same environmental and experimental conditions. Indeed, one of the benefits of using the described methodology was that all potential interference with the experiments was eliminated during the laboratory and to large extent during the on-farm phases of the project.

## **18.4 Results and discussion**

### **18.4.1 Laboratory studies**

Figure 18.5 shows the soiled hygiene pavers undergoing various cleaning process as described in Table 18.2.

The different cleaning processes resulted in varying degrees of success with cleaning, both visually and microbiologically. Pressure washing and the degreasing process led to the best post cleaning appearance visually, while dry scrubbing alone or in combination with flaming resulted in the least appealing visual cleanliness.

Figures 18.6-18.15 show post cleaning bacterial loads for various cleaning methods studied.

The results of the first experiment are presented in Figure 18.6 and the results of a related study is presented in Figure 18.7 (Banhazi *et al.*, 2003). The number of colony forming units (cfu) was higher ( $18 \times 10^4$  cfu/cm<sup>2</sup>) on the surface of the hosed hygiene pavers, compared to the high pressure washed hygiene pavers ( $14 \times 10^4$  cfu/cm<sup>2</sup>), but the difference was not significant ( $P=0.35$ ). However, experiments conducted previously using almost identical methodology demonstrated the superior cleaning ability of pressure washers, compared to hosing (Banhazi *et al.*, 2003). The results of the this current and the previous experiments (Banhazi *et al.*, 2003) demonstrate that even slight differences in cleaning procedures could result in significantly different outcomes. Thus the correct use of the cleaning procedure is probably just as critical as the nature of the



## 18. Practical evaluation of cleaning methods that could be implemented in livestock buildings



Figure 18.5. Various cleaning methods applied to soiled floor pavers. (a) hosing; (b) pressure washing; (c) degreasing; (d) dry scrubbing with wire brush; (e) liming using builder's lime; and (f) flaming.

cleaning method itself. It is very likely that during the current experiment the non-significant difference between the two cleaning methods was not the result of the underperformance of the pressure washing technique. Indeed, it is most likely that the cleaning method using simple 'hosing' resulted in a better than expected microbiological cleanliness, approaching the level of pressure washing. This is hypothesised as the residual bacterial load on hygiene pavers treated

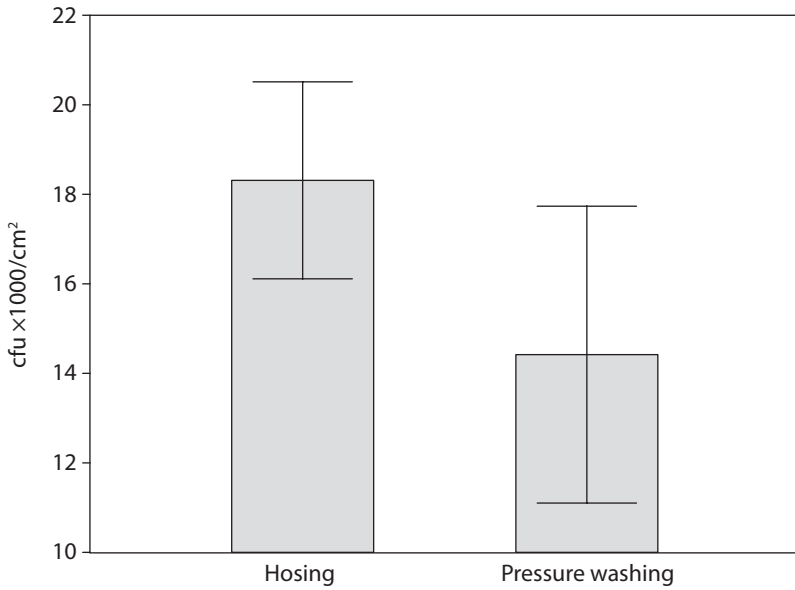

Figure 18.6. Post cleaning bacterial load (mean ± standard error) of hygiene pavers (colony forming units per cm<sup>2</sup>): hosing vs. pressure washing (P=0.35), 8 hygiene pavers used for each treatment.

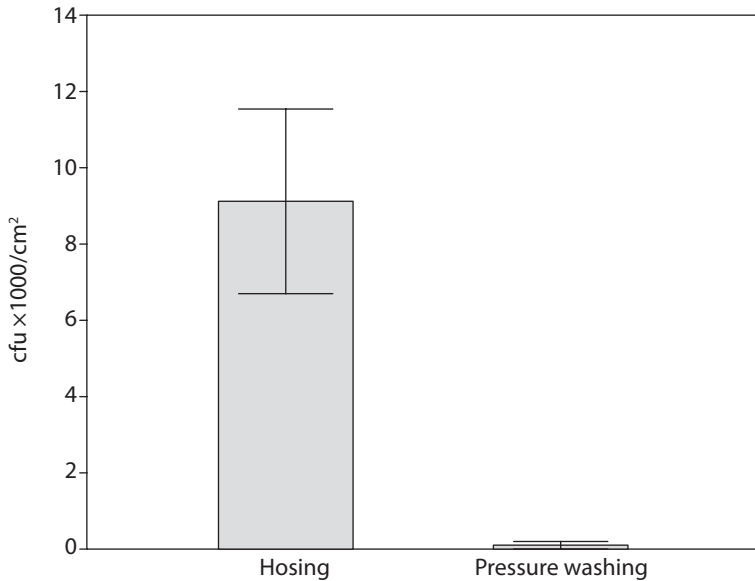

Figure 18.7. Post cleaning bacterial load (mean ± standard error) of hygiene pavers (colony forming units per cm<sup>2</sup>): hosing vs. pressure washing (P<0.001), 3 hygiene pavers used for each treatment (Banhazi et al., 2003).

## 18. Practical evaluation of cleaning methods that could be implemented in livestock buildings

by both cleaning methods was very low. This improved performance of the hosing techniques could have been the result of higher main water pressure than usual or improved cleaning ability of the water used.

It has to be emphasised that the current experiment focused on the surface hygiene of the cleaned floor segments (hygiene pavers), ignoring other effects, such as the aerosol generating nature of pressure washing. Anecdotal reports of the potential drawbacks of pressure washing in poorly ventilated areas is its tendency to re-distribute small particles (in the form of very fine aerosol) in the air, which can later settle on horizontal surfaces and potentially re-infect these surfaces. The result of a related study demonstrated that even thoroughly cleaned surfaces can be easily re-infected with bacteria via dirty, dusty air (Banhazi *et al.*, 2003).

Pressure washing can also pose an occupational health and safety hazard, if no protective equipment is worn by workers undertaking the cleaning task. However, the experiment demonstrated, what is generally accepted in practice, that both hosing and high pressure washing could improve both the visual and bacteriological cleanliness of floor surfaces, if correctly applied.

Experiment two (Figure 18.8) demonstrated that using a degreaser ( $147 \times 10^4$  cfu/cm<sup>2</sup>) can significantly improve cleanliness compared to hosing ( $542 \times 10^4$  cfu/cm<sup>2</sup>). Interestingly, degreasing also resulted in an excellent cleaning effect (Figure 18.9) during a previous study (Banhazi *et al.*, 2003), confirming the results of the current study. The number of cfu was significantly higher on the surface of hosed hygiene pavers, compared to the degreased hygiene pavers in both studies and the difference was about four fold. This experiment demonstrated that the use of degreaser could potentially help producers to achieve a very high level of floor cleanliness. However, this is only true, if the soiling of pen surfaces is totally removed. Any residual soiling will significantly decrease the biological cleanliness of pen surfaces. Thus, certain amount of contact time is required by degreaser products to realise their beneficial effects.

However, the results of a previous study demonstrated that the beneficial effects of degreasers do not linearly increase with increased contact time (Banhazi *et al.*, 2003). In a previous experiment non-significant differences were detected between the concentrations of cfus measured on the surface of the hygiene pavers degreased for 1, 2 or 3 hours (Banhazi *et al.*, 2003). It appeared that after leaving the degreaser on the soiled surface of the experimental hygiene pavers for an hour, any further increase in degreasing time did not result in any improvements. We have demonstrated under experimental conditions that the degreaser needs to be left on the floor surface for at least one hour. However, under commercial conditions, where the level of soiling could be much worse than under experimental conditions, a longer degreasing time might be warranted. Specific degreasers are also expected to work differently, resulting in a different optimal soaking time. However, producers should be aware that the benefits of degreasing do not necessarily increase in a linear fashion with increased soaking time. Based on the results of the current and previous experiments; it is most likely that an optimal soaking time exists for different degreasers, above which no extra benefits are to be gained. Observing and strictly adhering to such optimal soaking times will ensure that producers will gain the maximum benefits achievable, while minimising the downtime and therefore the expenditure associated with the cleaning method used. Overall



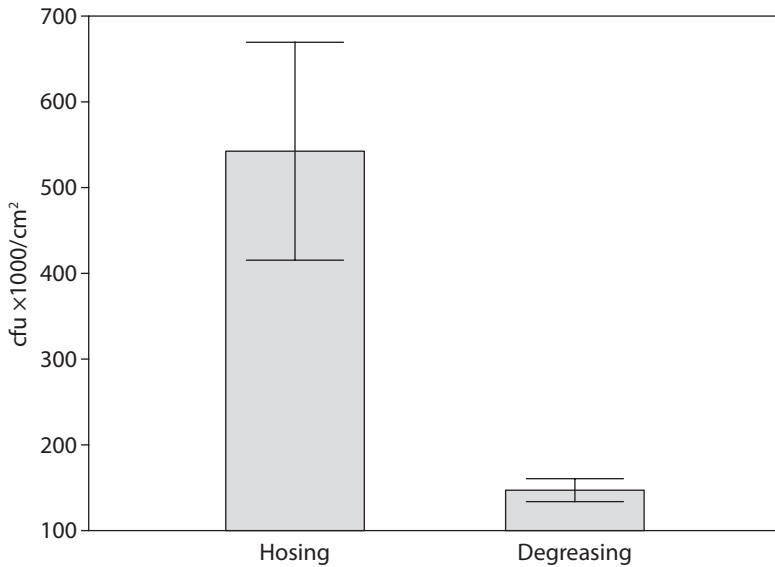

Figure 18.8. Post cleaning bacterial load (mean  $\pm$  standard error) of hygiene pavers (colony forming units per  $\text{cm}^2$ ) on the hygiene pavers: hosing vs. degreasing ( $P=0.006$ ), 4 hygiene pavers per treatment.

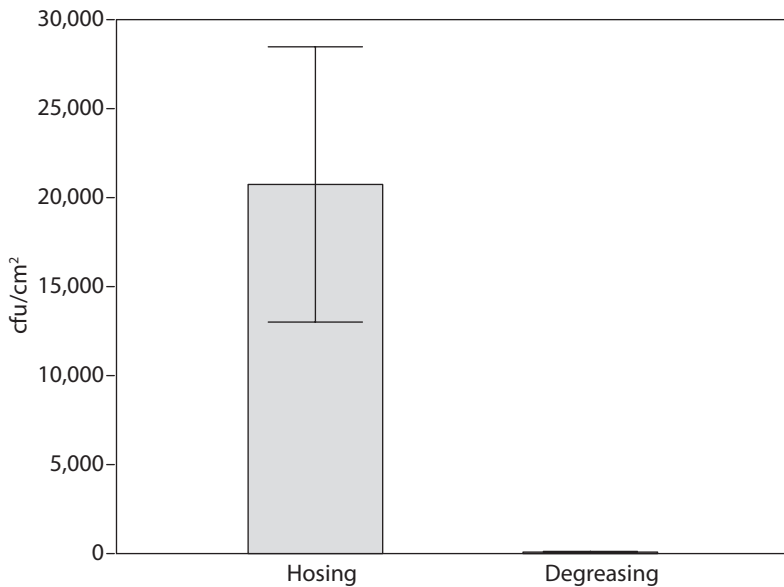

Figure 18.9. Post cleaning bacterial load (mean  $\pm$  standard error) of hygiene pavers (colony forming units per  $\text{cm}^2$ ) hosing vs. degreasing washing ( $P<0.001$ ), 3 hygiene pavers used for each treatment (Banhazi et al., 2003).

## 18. Practical evaluation of cleaning methods that could be implemented in livestock buildings

the use of degreaser products is highly recommended, as their beneficial effects were confirmed by two separate studies (Banhazi *et al.*, 2003).

Experiment three demonstrated that although visually better cleaning was achieved with hosing, the residual bacterial load of hosed hygiene pavers were 15% higher when compared to dry scrubbing method ( $390 \times 10^4$  cfu/cm<sup>2</sup> vs.  $338 \times 10^4$  cfu/cm<sup>2</sup>; Figure 18.10). These results indicated that hosing was slightly but not significantly ( $P=0.12$ ) worse than scrubbing. Therefore, dry scrubbing did not contribute to improvement of cleaning efficiency as much as was expected. Another point is that hosing during this experiment ‘underperformed’ highlighting the potentially varied nature of cleaning outcomes. This is despite the fact that very strict experimental procedures were implemented during this study. Thus, it can be expected that the efficiency of cleaning methods on farms (where the implementation of cleaning procedures may be less strict) can be highly variable.

The main aim of experiment four was to assess the effects of dry scrubbing and heat treatment on the resulting surface bacterial load (Figure 18.11). Flamed hygiene pavers ( $597 \times 10^4$  cfu/cm<sup>2</sup>) had significantly ( $P=0.008$ ) less residual bacterial load than hosed ( $843 \times 10^4$  cfu/cm<sup>2</sup>) hygiene pavers resulting in approx. 30% reduction. Flaming seems to destroy vegetative cells but it is recognised that the elimination of spores may depend on the heat maintenance and the efficiency of heat transfer to the surface. Thus it is suggested that further studies need to be undertaken to understand and thus improve the efficiency of heat transfer. Further improvements in dry

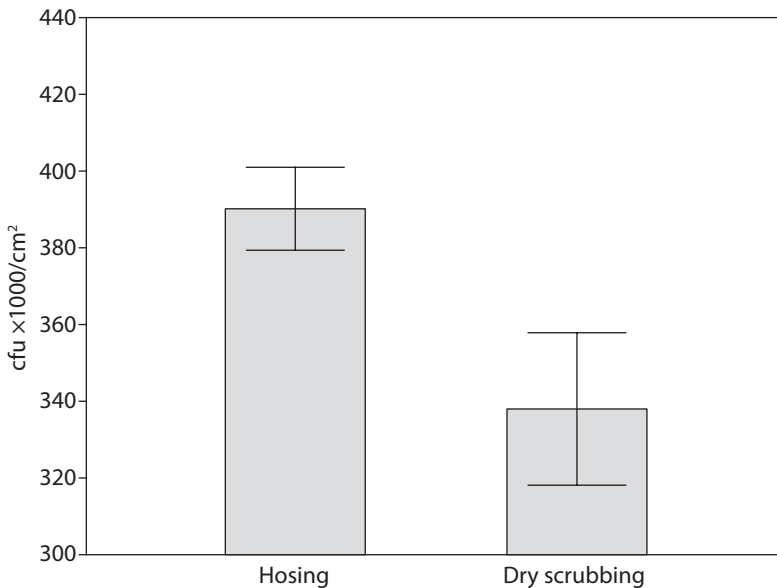

Figure 18.10. Post cleaning bacterial load (mean  $\pm$  standard error) of hygiene pavers (colony forming units per cm<sup>2</sup>): hosing vs. dry scrubbing ( $P=0.12$ ), 3 hygiene pavers per treatment.

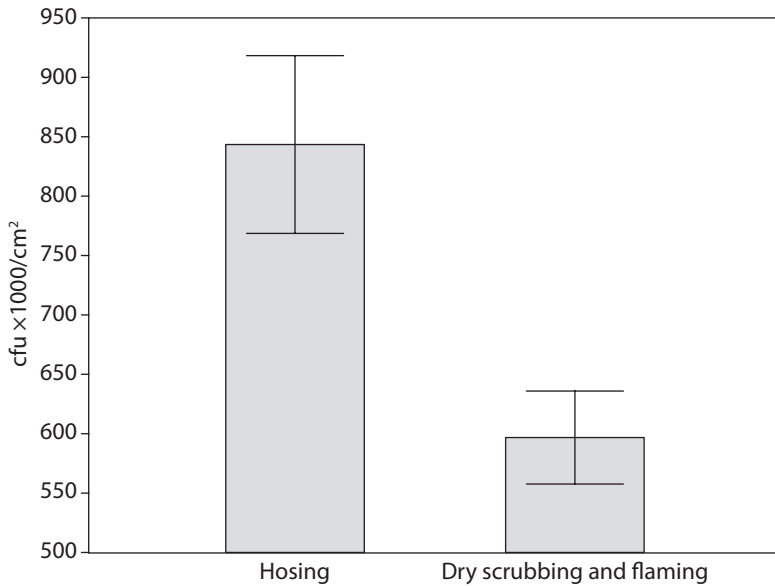

Figure 18.11. Post cleaning bacterial load (mean ± standard error) of hygiene pavers (colony forming units per cm<sup>2</sup>): hosing vs. dry scrubbing and flaming (P=0.008), 4 hygiene pavers per treatment.

scrubbing and flaming techniques could also result in improved bacterial cleanliness of piggery environments, while improving the safety and efficiency of this cleaning method.

Experiment 5-7 all aimed at assessing different aspects of using dry cleaning methods in combination with the application of lime-solution on surface bacterial load of hygiene pavers (Figure 18.12-18.15). Experiment five demonstrated the effects of applying a thick lime solution to hygiene pavers as a single effect, while experiment six and seven demonstrated the effects of lime application in combination with temperature differences and increased down-time.

Liming ( $506 \times 10^4$  cfu/cm<sup>2</sup>) resulted in the detection of higher bacterial load on the surfaces of the hygiene pavers when compared to dry scrubbing ( $422 \times 10^4$  cfu/cm<sup>2</sup>), but the difference was not statistically ( $P=0.30$ ) significant (Figure 18.12). These results are counter intuitive and likely resulted from progressive microbial growth within the microscopic crevices of the concrete hygiene pavers (Figure 18.13). Liming generally has been found to have a disinfectant affect via denaturalising bacterial cells (Heinonen-Tanski *et al.*, 2006; Venglovsky *et al.*, 2006). However, the current study demonstrated that a very thick lime solution can form a protective film over contaminated surfaces thus encouraging further microbial growth underneath the protective layer that can provide a moist and relatively warm environment. Figure 18.14 shows a schematic diagram explaining the possible venue for bacterial growth in micro crevices on the paver surface.

The main aim of experiment six was to assess the potential climatic/temperature effects on cleaning efficiency and thus on the resulting surface bacterial load (Figure 18.13). The four

**18. Practical evaluation of cleaning methods that could be implemented in livestock buildings**

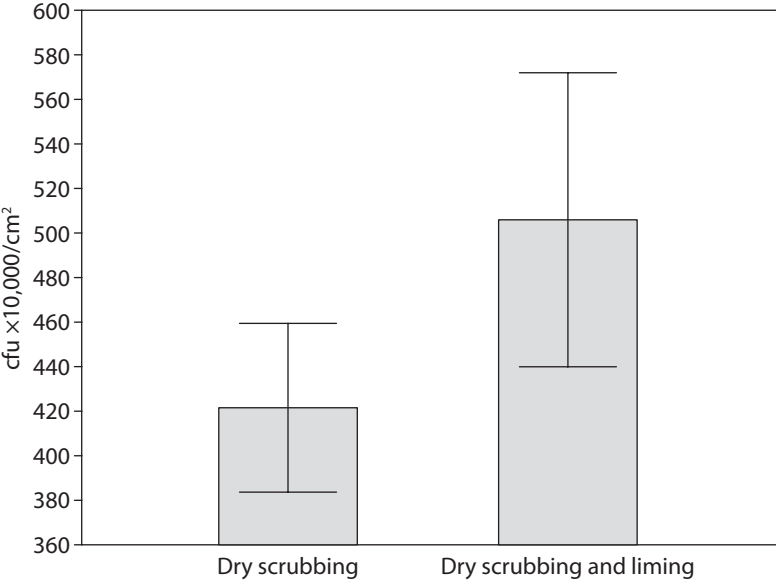

Figure 18.12. Post cleaning bacterial load (mean ± standard error) of hygiene pavers (colony forming units per cm²): scrubbing vs. dry scrubbing and liming (P=0.30), 4 hygiene pavers per treatment.

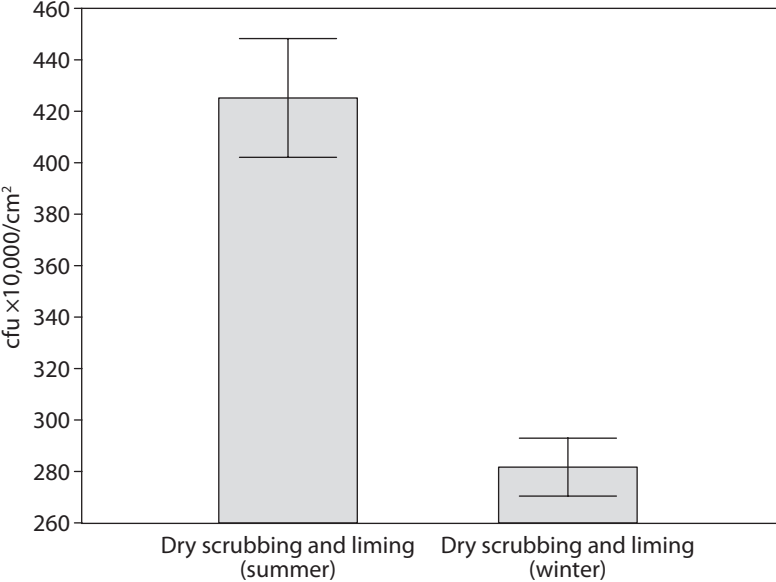

Figure 18.13. Post cleaning bacterial load (mean ± standard error) of hygiene pavers (colony forming units per cm²): dry scrubbing and liming (temperature difference) (P<0.001), 4 hygiene pavers per treatment.

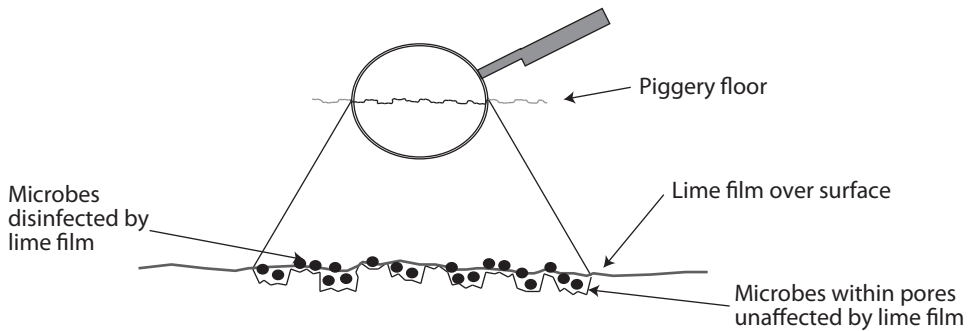

Figure 18.14. Post liming bacterial growth on paver surface.

hygiene pavers that were dry cleaned, lime-treated and kept artificially heated at 37 °C (mimicking summer conditions) for 24 h before being swabbed had significantly ( $P < 0.001$ ) higher bacterial load ( $425 \times 10^4$  cfu/cm<sup>2</sup>), when compared to hygiene pavers that were treated in the same way but cooled in a fridge (mimicking winter conditions) at 8 °C ( $281 \times 10^4$  cfu/cm<sup>2</sup>). These results underpinned the results of the previous experiment, and demonstrate that underneath the thick lime solution bacterial activity could take place that is obviously enhanced at higher temperatures. Due to the slow drying of the thick lime solution, the drying effect of increased heat is reduced, thus providing a warm and moist microclimate for bacterial growth.

The appearance of the lime solution used during the experiment was very thick/viscous but the solution was made up to mimic the solution used on farms (B. Lloyd, personal communication) Based on these results, it will be advisable to reduce the concentration of the lime solution from the currently used (11% w/v) to perhaps half around 5-6% weight/volume. This would result in a number of benefits. First, the application cost would significantly decrease as less lime would be used per unit volume of mix. In addition, the viscosity of the mix would decrease facilitating the more even spread, deeper penetration of the thinner solution into the micro-crevices of the concrete floor. During the experiment it was relatively easy to observe visually that the very viscous lime/water mixture, did not penetrate but 'sat on the top' of the concrete floor.

In addition, the thinner solution would dry quicker, that would definitely improve the disinfectant effect of the solution. Previous experiments demonstrated the beneficial effects of thoroughly drying concrete pen floor, as even after full disinfection, further improvements was achieved by allowing hygiene pavers to dry for 48 h (Banhazi *et al.*, 2003). The results of previous experiments and indirectly the current experiment are reinforcing the need for drying pens on commercial farms thoroughly before re-stocking and avoiding practices that would keep the surface of concrete floors moist for an extended period of time.

The aim of experiment seven was to assess the effects of using dry cleaning methods in combination with the application of lime-solution and increased down-time on residual bacterial load of hygiene pavers (Figure 18.15). The hygiene pavers that were dry cleaned, treated with lime-solution and sampled almost immediately had lower concentration of residual bacteria ( $573 \times 10^4$

## 18. Practical evaluation of cleaning methods that could be implemented in livestock buildings

cfu/cm<sup>2</sup>) than hygiene pavers that were sampled after 24, 48 (1,242/1,172×10<sup>4</sup> cfu/cm<sup>2</sup>) and 72 hours (3,455×10<sup>4</sup> cfu/cm<sup>2</sup>). Again, this experiment appears to confirm the results of previous lime-treatment related experiments that indicate bacterial growth might occur underneath the thick lime solution and the bacteria number can potentially increase with time (Figure 18.15) and also with increased temperature (Figure 18.13). As indicated before, thinner lime solution that would dry quicker and would penetrate the micro-crevices of the concrete floor might be the solution for this identified problem.

### 18.4.2 On farm evaluation

Laboratory investigations aimed at assessing the efficacy of commonly employed cleaning methods in livestock buildings (as detailed above) revealed that degreasing and dry scrubbing/flaming resulted in significant reduction of residual bacterial load on the surfaces of hygiene pavers. However, the limitations of essentially small-scale laboratory based studies were acknowledged as these were based on application of a homogenous slurry from a single sample collected at a specific farm. It must be noted that several factors influence the bacterial load present on the paver surface including the microbial composition in the pig manure, category of pigs, their diet, age group of animals and duration of animal stay in the building. Under such constraints, two follow-up experiments were initiated and executed under commercial farm conditions in weaner sheds. These follow up studies were used to verify the results of the previous laboratory

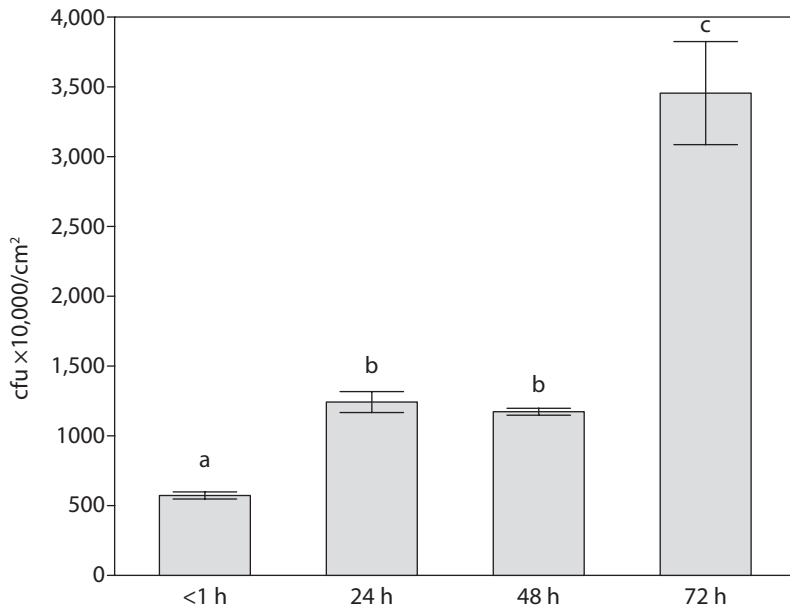

Figure 18.15. Post cleaning bacterial load (mean  $\pm$  standard error) of hygiene pavers (colony forming units per cm<sup>2</sup>): dry scrubbing vs. dry scrubbing and liming and increased down-time (P<0.001), 2 hygiene pavers per treatment (different letters above the columns indicate statistically significant difference).

based experiments. The current study may need to be replicated for site specific adoption of these techniques.

These 'before/after' studies generated (Figure 18.16 and 18.17) results that underpinned the applicability of both the cleaning methods on farms and confirmed/validated the results achieved under laboratory conditions. Both dry scrubbing and flaming the floor ( $92 \times 10^4$  cfu/cm<sup>2</sup>) and degreasing ( $111 \times 10^4$  cfu/cm<sup>2</sup>) significantly reduced the residual bacterial load of the floor sections when compared to the control samples ( $153 \times 10^4$  cfu/cm<sup>2</sup> and  $183 \times 10^4$  cfu/cm<sup>2</sup>, respectively). Thus these on-farm results confirmed the beneficial effects of the evaluated cleaning methods.

In summary, this study demonstrated the comparative benefits of the selected cleaning methods. Given the time and financial limitation of this study, it aimed at assessing the methods that were of particular interest for the Australian pig industry at the time of the study. The reported study did not aim to assess all possible cleaning methods, but provided a framework and methodology for future follow-up studies. Some additional cleaning methods, including one of the most commonly used decontamination methods (soaking, cleaning, disinfecting and then drying) were assessed as part of an earlier study (Banhazi *et al.*, 2003). In addition, the authors also acknowledge that other important aspects of the cleaning methods applied, such as appropriateness of flaming in pens with plastic floors or the possible corrosive effects of regular liming were not considered. However, the study simply wanted to demonstrate the relative benefits of selected cleaning methods and not necessarily advise for or against any particular method. The ultimate decision of the application of specific cleaning methods used on particular farms have to be made by

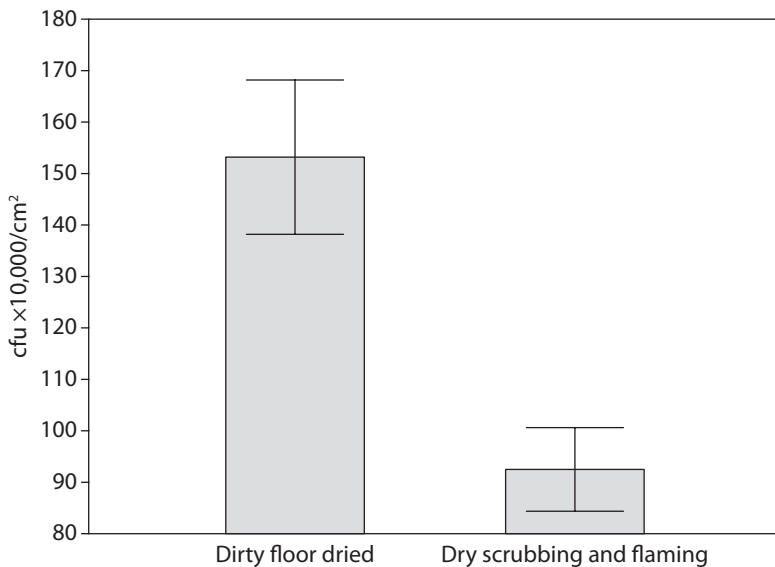

Figure 18.16. Post cleaning bacterial load (mean  $\pm$  standard error) of hygiene pavers (colony forming units per cm<sup>2</sup>): control vs. dry scrubbing and flaming ( $P=0.002$ ), 16 samples per treatment.

## 18. Practical evaluation of cleaning methods that could be implemented in livestock buildings

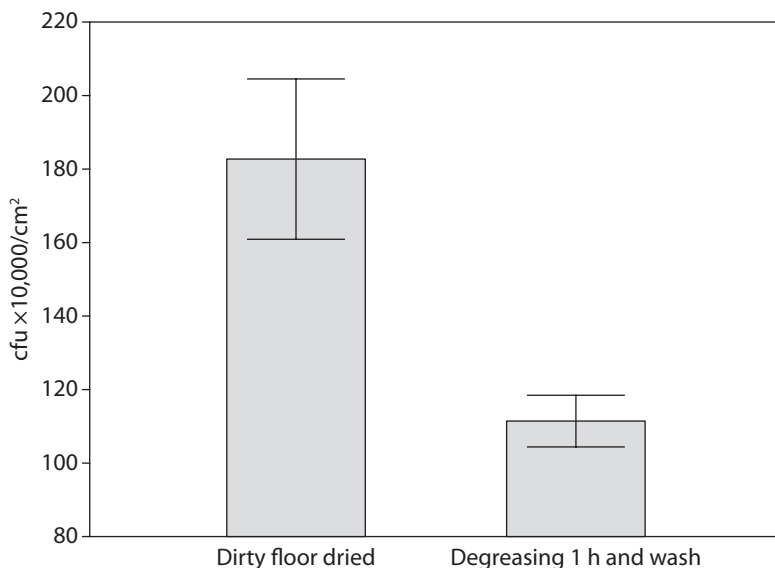

Figure 18.17. Post cleaning bacterial load (mean  $\pm$  SE) of hygiene pavers (colony forming units per cm<sup>2</sup>): hosing vs. pressure washing ( $P=0.004$ ), 16 samples per treatment.

farm managers. Equally, it was recognised that the bacterial composition of manure can vary significantly between farms. Thus the resulting bacterial load documented in this study are not absolute, but relative values. However, it was essential during this study to standardise the bacterial content of the manure used, so reliable comparison can be made between the treatments. While it is likely that different results will be achieved on other farms when using manure with different bacterial content; it is hoped that the relative reduction or the trend in reduction will be similar even on other farms. The positive results achieved during the on-farms component of this study support this assumption.

### 18.5 Conclusions

A study was initiated and implemented to evaluate a number of practical cleaning methods aimed at improving hygiene conditions in pig pens. The cleaning methods assessed using concrete 'hygiene-pavers' included hosing, pressure washing, degreasing, dry scrubbing and flaming, liming and dry scrubbing. It was concluded that:

- The utilisation of degreasing or dry scrubbing and flaming can result in high levels of bacterial cleanliness of concreted surfaces.
- Liming did not result in the expected hygiene improvement. This might be related to the fact that the currently used very thick lime solution does not allow the surfaces to dry effectively. In addition, the ability of the thick lime solution to penetrate micro-crevices of the concrete floor and therefore to maximise contact with the surface of the floor was also questioned.



Using thinner lime solution on farms to improve the disinfecting ability of the mixture was suggested based on the results of this study.

The study results also indicated that further investigation is required to optimise liming and flaming procedures.

## **Acknowledgements**

The financial support of the South Australian Pig Industry Fund (PIF), the technical support of the Roseworthy Research Piggery staff and the Pig Industry Advisory Group (PIAG) are gratefully acknowledged.

## **References**

- Algers, B., 2000. Animal hygiene: a corner-stone in animal welfare. 10<sup>th</sup> International Congress on Animal Hygiene, July 2-6, 2000, Maastricht, the Netherlands, pp. 719-724.
- ASM, 1996. Guidelines for assuring quality of medical microbiological culture media. Media Quality control special interest group, Australian society for Microbiology, Melbourne, VIC, Australia.
- Banhazi, T. and Cargill, C., 1997. The effects of general hygiene on air quality in mechanically ventilated weaner rooms. In: Cranwell, P.D. (ed.) Manipulating pig production VI, Werribee, Victoria, Australia. APSA, Corowa, Australia, pp. 296.
- Banhazi, T., Hillyard, K., Murphy, T. and Kloppers, M., 2002. The effects of floor wetting on established dunging patterns. In: Revell, D.K. and Taplin, D. (eds.) Animal production in Australia. ASAP, QLD, Australia, pp. 373.
- Banhazi, T., Murphy, T. and Hartung, J., 2003. Using 'hygiene-pavers' to evaluate cleaning procedures used on pig farms. In: Saltieral, J.A. (ed.) XIth International Congress in Animal Hygiene (ISAH), 23-27 February 2003, Metropolitan University, Mexico City. CD publication.
- Banhazi, T.M., Currie, E., Quartararo, M. and Aarnink, A.J.A., 2009a. Controlling the concentrations of airborne pollutants in broiler buildings. In: Aland, A. and Madec, F. (eds.), Sustainable animal production: the challenges and potential developments for professional farming. Wageningen Academic Publishers, Wageningen, the Netherlands, pp. 347-364.
- Banhazi, T.M., Currie, E., Reed, S., Lee, I.-B. and Aarnink, A.J.A., 2009b. Controlling the concentrations of airborne pollutants in piggery buildings. In: Aland, A. and Madec, F. (eds.), Sustainable animal production: the challenges and potential developments for professional farming. Wageningen Academic Publishers, Wageningen, the Netherlands, pp. 285-311.
- Banhazi, T.M., Rutley, D.L. and Pitchford, W.S., 2008a. Identification of risk factors for sub-optimal housing conditions in Australian piggeries – Part IV: Emission factors and study recommendations. *Journal of Agricultural Safety and Health* 14: 53-69.
- Banhazi, T.M., Seedorf, J., Laffrique, M. and Rutley, D.L., 2008b. Identification of risk factors for high airborne particle concentrations in broiler buildings using statistical modelling. *Biosystems Engineering* 101: 100-110.
- Banhazi, T.M., Seedorf, J., Rutley, D.L. and Pitchford, W.S., 2008c. Identification of risk factors for sub-optimal housing conditions in Australian piggeries – Part I: study justification and design. *Journal of Agricultural Safety and Health* 14: 5-20.

## 18. Practical evaluation of cleaning methods that could be implemented in livestock buildings

- Banhazi, T.M., Seedorf, J., Rutley, D.L. and Pitchford, W.S., 2008d. Identification of risk factors for sub-optimal housing conditions in Australian piggeries – Part II: airborne pollutants. *Journal of Agricultural Safety and Health* 14: 21-39.
- Banhazi, T.M., Seedorf, J., Rutley, D.L. and Pitchford, W.S., 2008e. Identification of risk factors for sub-optimal housing conditions in Australian piggeries – Part III: environmental parameters. *Journal of Agricultural Safety and Health* 14: 41-52.
- Cargill, C. and Banhazi, T., 1998. The importance of cleaning in all-in/all-out management systems. In: Cargill, C. and McOrist, S. (eds.) *Proceedings of the 15<sup>th</sup> IPVS Congress*. University of Birmingham, Birmingham, UK, pp. 15.
- Cargill, C.F., Banhazi, T. and Humphris, R., 1996. Improving air quality and production by converting existing facilities to all-in/all-out systems. *Proceedings of the 14<sup>th</sup> International Pig Veterinary Society Congress*, Bologna, Italy, p. 509.
- De Belie, N., Lenehan, J.J., Braam, C.R., Svennerstedt, B., Richardson, M. and Sonck, B., 2000. Durability of building materials and components in the agricultural environment, Part III: concrete structures. *Journal of Agricultural Engineering Research* 76: 3-16.
- Donham, K.J., Cumro, D., Reynolds, S.J. and Merchant, J.A., 2000. Dose-response relationships between occupational aerosol exposures and cross-shift declines of lung function in poultry workers: Recommendations for exposure limits. *Journal of Occupational and Environmental Medicine* 42: 260-269.
- Donham, K.J., Haglund, P., Peterson, Y., Rylander, R. and Belin, L., 1989. Environmental and health studies of farm workers in Swedish swine confinement buildings. *British Journal of Industrial Medicine* 46: 31-37.
- Donham, K.J., Merchant, J.A., Lassise, D., Popendorf, W.J. and Burmeister, L.F., 1990. Preventing respiratory disease in swine confinement workers: intervention through applied epidemiology, education, and consultation. *American Journal of Industrial Medicine* 18: 241-261.
- Duchaine, C., Grimard, Y. and Cormier, Y., 2000. Influence of building maintenance, environmental factors, and seasons on airborne contaminants of swine confinement buildings. *American Industrial Hygiene Association Journal* 61: 56-63.
- Heinonen-Tanski, H., Mohaibes, M., Karinen, P. and Koivunen, J., 2006. Methods to reduce pathogen microorganisms in manure. *Livestock Science* 102: 248-255.
- Lee, C., Giles, L.R., Bryden, W.L., Downing, J.L., Owens, P.C., Kirby, A.C. and Wynn, P.C., 2005. Performance and endocrine responses of group housed weaner pigs exposed to the air quality of a commercial environment. *Livestock Production Science* 93: 255-262.
- Madec, F., 2013. Aiming at building cleanliness to keep livestock healthy. In: Aland, A. and Banhazi, T. (eds.) *Livestock housing: modern management to ensure optimal health and welfare of farm animals*. Wageningen Academic Publisher, Wageningen, the Netherlands, pp. 331-354.
- Madec, F., Bridoux, N., Bounaix, S. and Jestin, A., 1998. Measurement of digestive disorders in the piglet at weaning and related risk factors. *Preventive Veterinary Medicine* 35: 53-72.
- NATA, 1992. Guidelines for the quality management of microbiological media. Technical note number 4. National Association of Testing Authorities, Silverwater, NSW, Australia.
- Ondrasovic, M., Ondrasovicova, O., Vargova, M., Dankova, J., Toropila, M. and Krajnak, M., 2000. Conclusions based on experiments and practical knowledge concerning the selection of disinfectants for focal disinfection. 10<sup>th</sup> International Congress on Animal Hygiene, July 2-6, 2000, Maastricht, the Netherlands, pp. 596-601.

- Rantzer, D. and Svendsen, J., 2001. Slatted versus solid floors in the dung area of farrowing pens: effects on hygiene and pig performance, birth to weaning. *Acta Agriculturae Scandinavica, Section A, Animal Sciences* 51: 167-174.
- Rantzer, D., Westrom, B. and Svendsen, J., 1998. Effects of different levels of pen hygiene from birth to 4 weeks after weaning on pig health, growth and immune parameters. 15<sup>th</sup> International Pig Veterinary Society Congress, Birmingham, UK, pp. 55.
- Robertson, J.F., Wilson, D. and Smith, W.J., 1990. Atrophic rhinitis: the influence of the aerial environment. *Animal Production* 50: 173-182.
- Roelofs, P.F.M.M., Hoofs, A.I.J. and Binnendijk, G.P., 1993. The influence of soaking procedure, water pressure, water-flow and nozzle on water usage and working time to clean pig houses with a high pressure cleaner. Verslag P 1.103, Varkensproefbedrijf 'Zuid- en West-Nederland', Sterksel, the Netherlands.
- Skirrow, S., Cargill, C., Mercy, A., Nicholls, R., Banhazi, T. and Masterman, N., 1995. Risk factors for pleurisy in pigs. DAW 28P, Pig Research and Development Corporation, Perth, Australia.
- StatSoft, I., 2001. STATISTICA. StatSoft, Inc., Tulsa, OK, USA.
- Takai, H., Pedersen, S., Johnsen, J.O., Metz, J.H.M., Groot Koerkamp, P.W.G., Uenk, G.H., Phillips, V.R., Holden, M.R., Sneath, R.W., Short, J.L., White, R.P., Hartung, J., Seedorf, J., Schroder, M., Linkert, K.H. and Wathes, C.M., 1998. Concentrations and emissions of airborne dust in livestock buildings in Northern Europe. *Journal of Agricultural Engineering Research* 70: 59-77.
- Tielen, M.J.M., 2000. Animal hygiene: the key to healthy animal production in an optimal environment, 10<sup>th</sup> International Congress on Animal Hygiene, July 2-6, 2000, Maastricht, the Netherlands, pp. 3-10.
- Venglovsky, J., Martinez, J. and Placha, I., 2006. Hygienic and ecological risks connected with utilization of animal manures and biosolids in agriculture. *Livestock Science* 102: 197-203.
- Wathes, C.M., 1994. Air and surface hygiene. In: Wathes, C.M. and Charles, D.R. (eds.) *Livestock housing*. CAB International, Wallingford, Oxon, UK, pp. 123-148.

## 19. Modelling and influencing hygiene conditions in Australian livestock buildings

T. Banhazi

National Centre for Engineering in Agriculture (NCEA), University of Southern Queensland, West Street, Toowoomba, QLD 4530, Australia; [thomas.banhazi@usq.edu.au](mailto:thomas.banhazi@usq.edu.au)

### Abstract

The main aims of the research presented here were: (1) to model the effects of important housing and management factors on the hygiene level of pig pens; and (2) to evaluate the efficacy of methods aimed at improving pen hygiene. These project aims were achieved by: (1) modelling the hygiene levels measured; and (2) conducting a number of controlled experiments. Hygiene levels were visually assessed in 160 piggery buildings using a standardised 3-step scale system. Engineering and management characteristics of the piggery buildings were recorded at the time of sampling and these building characteristics were used in the subsequent multi-factorial statistical analysis. The mean faecal contamination of pen floors in all study buildings was 36%. According to the model developed, hygiene levels were affected by the size of the farm (as described by the number of sows), seasons, stocking rate per pen (kg weight/m<sup>2</sup>) and management of piggery buildings. Summer conditions and continuous flow pig management resulted in reduced hygiene levels in pig pens. Piggery size positively, whereas stocking rate negatively associated with piggery hygiene. The results highlighted potential strategies that can be used to reduce the negative effects of sub-optimal piggery hygiene on pig production, environment, health and welfare of animals as well as piggery staff. The related experiments highlighted the importance of keeping pens dry and potentially using bedding materials to mark resting areas in pens as a means of improving dunging patterns in pig pens.

**Keywords:** manure, dunging, pigs, hygiene, management, season, cleanliness

### 19.1 Introduction

Since the introduction of partially slatted floors in piggery buildings, the excretory behaviour of pigs has become a crucial factor in the successful management of pig housing systems (Aarnink *et al.*, 1996; Hacker *et al.*, 1994). The pig's excretory activity can affect the pig's and pen cleanliness (Figure 19.1) with obvious consequences for pig health, worker safety and farm productivity (Watson, 1978). Incorrect dunging patterns in partly slatted pens may lead to performance problems and almost certainly lead to management and labour problems. Previous studies demonstrated a very strong association between pen hygiene (the percentage of solid floor covered by dung) and air quality (Banhazi *et al.*, 2008b, 2010; Takai *et al.*, 1998). Unfortunately, very little information is available on the factors affecting the excretory behaviour of pigs as in practice many factors could affect the development of dunging patterns in pig pens (Olsen *et al.*, 2001; Randall, 1980). It is generally accepted that several stimuli act together to produce the pigs dunging pattern in pens (Wechsler and Bachmann, 1998).



Figure 19.1. Examples of pig pens with good and wrong dunging patterns.

An ideal situation would be for the pigs to eat and sleep and not excrete in the solid area and to drink and excrete in the area which is slatted. The pigs will ideally deposit and then trample on the excreta forcing it to fall through the slats into a channel or pit below, which would then be flushed or scraped depending on the waste management system. The success of this system relies on providing conditions that encourage the pigs to excrete only on the slatted area of the pen.

There is some debate as to whether the pigs' preference for a dunging site is related to its microenvironment or it is the least desirable area in which to lie. The aim of dunging pattern management should be to make the designated resting place (concreted area in partly slatted pens) as attractive as possible for the pigs to rest. The slatted areas, on the other hand, should be made unattractive as resting-places (Turner and Lockhart, 1987).

It is believed the effects of thermal environment are very important (Randall *et al.*, 1983) in influencing dunging patterns. It is generally accepted (Baxter, 1982; Olsen *et al.*, 2001) that in piggeries situated in northern hemisphere countries, pigs like to lie in a warmer area and excrete in a cooler place. This could become a problem when pigs are housed in areas above their thermo-neutral temperature range, as often happens in Australia. During a hot period, the pigs are likely to lie in the cool area which is generally the dunging area.

An experiment by Baxter (1982) demonstrated that excretory behaviour of pigs could be influenced by the location of the drinkers and thus floor wetness. It was found that pigs kept in smaller pens, tended to excrete near the drinkers (wet area) and avoided excreting on the resting area. It was suggested that this behaviour might relate to the microclimate created by the water (evaporative cooling) and the wetness itself, which may simulate excretory behaviour and indicate the position of the regular dunging area.

Crowding and disturbance by other pigs will result in fouling of the solid pen surface (Bate *et al.*, 1988; Hacker *et al.*, 1994). Bate *et al.* (1988) suggested that pigs seek isolation for excretory behaviour and that as the animals mature, this isolation becomes more difficult to achieve, and thus pigs tend to develop incorrect dunging patterns near market weight. This compares well with the findings of Hacker *et al.* (1994) who found that increases in pig age and pig weight tend to also increase pen fouling. It has been shown that pigs generally demonstrate a clear preference

## 19. Modelling and influencing hygiene conditions in Australian livestock buildings

for defecating in areas that are separate from the lying areas (Simonsen, 1990; Watson, 1985). However, under intensive housing conditions, all pigs housed in the same pen might not be able to use the same 'toilet area.' Thus under commercial conditions, total separation of lying and dunging area may not consistently be achieved.

A study found that piglets prefer to dung close to a wall (Petherick, 1982). This is suggested to be related to a need for security as the piglet feels that it may be disturbed while defecating in exposed areas. This study appears to agree with conclusions drawn by other experiments, emphasising the effects of commotion on excretory behaviour (Bate *et al.*, 1988).

In summary, temperature, commotion and management are clearly cited in the literature as critical factors influencing the development of dunging patterns in commercial piggeries. However, it is not known what factors will influence dunging pattern in Australia under commercial conditions. Therefore, a study was designed with two aims in mind. First to identify the statistically significant factors affecting pen soiling in Australian piggery buildings and then to assess practical management interventions aimed at influencing dunging patterns under commercial farm conditions and thus improving pen and building hygiene.

### 19.2 Materials and methods

#### 19.2.1 Study component 1: field survey and statistical modelling

Details of the design of the study, techniques used for environmental data collection and analysis have been given previously (Banhazi *et al.*, 2008a,b). A total of 160 piggery buildings were included in a study, and housing and management information relevant to individual buildings were documented in detail. Environmental information, including temperature and humidity readings were recorded in all buildings using Tinytalk temperature and humidity data loggers (Tinytalk-2, Hasting Dataloggers, Australia) over a 60 h period.

The dunging pattern in the study buildings were assessed at the time of data collection by classifying the pen cleanliness into three distinct classes, as were done in previous studies (Aarnink *et al.*, 1996, 1997). Pen hygiene was deemed to be 'good' if less than 10% of pen floor was contaminated by faecal material (average area covered by dung = 5%). If between 10 and 50% of the pen floor was contaminated with faecal material, then the hygiene level was deemed to be 'fair' (average area covered by dung = 25%). More than 50% floor contamination resulted in the pen classified as having 'bad' pen hygiene (average area covered by dung = 75%). The data collected was forwarded to South Australia for storage and analysis. To facilitate meaningful data analysis, the classification grades were later turned into percentages, as described above. The dependent variable of interest for this study was the extent of floor contamination (%) with manure. The data was analysed using the forward selection procedure in General Linear Model (GLM PROC) (SAS, 1989). The results presented here are based on the least squares means ( $\pm$  confidence intervals) of fixed effects. As the hygiene standards of pig pens are influenced by many factors, the model was developed at the 90% confidence level to ensure that all important effects likely to influence dunging patterns will be identified.

### 19.2.2 Study component 2: controlled experiment

A limited number of follow-up and controlled experiments were conducted at the University of Adelaide, Roseworthy Research Piggery to evaluate the effects a number of practical management procedures on dunging pattern as listed in Table 19.1.

The management intervention applied and the facilities used are described in details below. Standard one-way ANOVA was used to evaluate the statistically significant changes between treatments and the control pens (StatSoft, 2001).

#### Experiment 1

The main aim of experiment was to assess the effects of wet pen floors on established dunging patterns in pig pen. Four pens were selected with perfect dunging patterns in partially slatted, naturally ventilated grower/finisher room housing with approximately 90 pigs at a stocking rate of 0.65 m<sup>2</sup>/pig. Two pens out of the four were randomly selected and the pen floors were thoroughly wetted using 8 l of water daily. The other two pens in the same rooms, stocked at the same rate, were used as control pens and the floors of these pens were kept dry. Dunging patterns were monitored for 25 days as described previously (Banhazi *et al.*, 2002). The amount of dung cover on the concreted areas were assessed daily and classified into three available categories (poor, fair and good).

#### Experiment 2

The main aim of this experiment was to assess the effects of using oil impregnated saw dust to influence the establishment of dunging patterns in newly stocked weaner pens. Four pens were selected in freshly cleaned partially-slatted, mechanically ventilated weaner room housing with approximately 15 pigs per pen at a stocking density of 0.34 m<sup>2</sup>/pig. Two of the four study pens were randomly allocated to the treatment, which was the application of sawdust on the concreted area.

Table 19.1. Description of controlled experiments aimed at assessing hygiene control methods.

Experiment	Aims	Comments
Wetting pen floors	to assess the effects of wet pen floors on established dunging patterns	attempts were made to artificially induce poor dunging patterns in pens with established good dunging pattern, by wetting the pen floors daily
Using oily saw-dust	to evaluate the effects of using bedding material impregnated with oil on dunging patterns	it was envisaged that the oil impregnated bedding material would improve dunging patterns without producing dust and would also deliver welfare benefits
Creating commotions	to study the effects of commotion on dunging patterns	commotion was created in specific areas of the pen, by attaching play-chains strategically at specific locations



## 19. Modelling and influencing hygiene conditions in Australian livestock buildings

The other two remaining pens in the same room, stocked at the same rate, were used as control pens and the floor of these pens did not receive sawdust application. Dunging patterns were monitored once a day for 14 days using a method described above. The experiment was repeated again with three pens used as control and three pens in the same room used as experimental facilities. The pens were de-stocked, cleaned and reallocated between experiments to avoid any carry over effects from previous experiments. The amount of dung cover on the concreted areas were assessed daily and classified into three available categories (poor, fair and good).

### *Experiment 3*

The main aim of the last experiment was to assess the effects of using play chains on the establishment of dunging patterns in a weaner room. Six pens were selected in a partially-slatted, naturally ventilated weaner room housing approximately 15 pigs per pen at the stocking rate of 0.34 m<sup>2</sup>/pig (Figure 19.2). Two of the six study pens were randomly allocated to treatment 'A' (application of play chains over the slat areas) and two were allocated to treatment 'B' (application of play chains over the concreted areas). The other two remaining pens in the same room, stocked at the same rate, were used as control pens and these pens did not have any play chains installed. Dunging patterns were monitored once a day for 20 days as described above.

## 19.3 Results and discussion

### **19.3.1 Study component 1: field survey and statistical modelling**

Table 19.2 summarizes the basic statistical measures of the raw data collected in the study buildings. The significance of each effect associated with pen hygiene is summarized in Table 19.3. Significant results are shown in Figures 19.3 and 19.4 and in Table 19.4. The study identified the key factors affecting hygiene levels inside pig building as: (1) farm size; (2) season; (3) management; and (4) stocking rate.



Figure 19.2. Play-chains in a weaner pen.



Table 19.2. Level of floor contamination (%) across all study buildings.

Parameter	Mean	SD	Range	No. of buildings
Contamination of pen floor by faecal material (%)	36	27	70	112

Table 19.3. Significance of effects associated with hygiene level in the model developed at the 90% confidence levels.

	Probability of the individual effects
Number of sows (farm size)	0.002
Management	0.006
Stocking rate per pen (kg weight/m <sup>2</sup> )	0.059
Season	0.086

Significantly higher percentage of floor contamination was observed in summer (46%) in piggery buildings than in winter (36%) (Figure 19.3). In piggery buildings, winter temperatures are lower than in summer, thus pigs tend to use the concreted areas appropriately for resting and the slatted areas for defecating. However, in summer when temperatures are high, pigs are forced to rest on the slatted area in order to keep themselves cool, thus making the slatted area unavailable for defecating. Studies by (Aarnink *et al.*, 2000, 2001) have also shown that the fouling of the solid pen area increases with increases in the ambient temperature. A clear ‘Inflection Temperature’, the temperature at which pen fouling increases, was found for a range of pig weights. This temperature ranged from 25 °C for 25 kg pigs to 20 °C for 100 kg pigs. Therefore, the main aim of managing dunging patterns in summer should be to discourage pigs to rest on the slatted areas. For example,

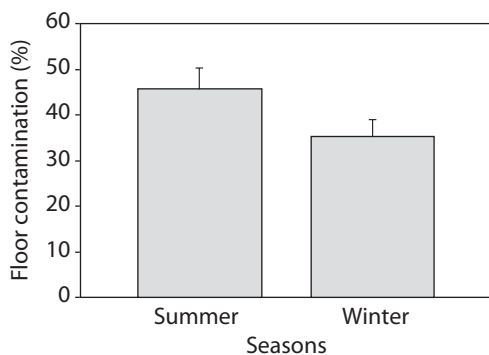

Figure 19.3. Effect of season on hygiene level (%) in Australian piggery buildings (LS means with standard error, P<0.05).

## 19. Modelling and influencing hygiene conditions in Australian livestock buildings

in an effort to reduce the fouling of the solid floor, Aarnink *et al.* (1997) employed slats embedded with a metal stud. This stud prevented the pig from lying on the slatted floor, forcing it to them lie on the solid floor. This significantly reduced the rate of urination and defecation on the solid floor.

Higher level of pen floor contamination was observed in continuous flow (CF) buildings (49%) when compared to building (32%) managed on the all-in/all-out (AIAO) basis (Figure 19.4). It is important to consider the management of the buildings, when assessing dunging patterns, as building management will directly influence both the thermal and social environment of pens. In addition, the beneficial effects of regular cleaning between batches will have a direct impact on pen cleanliness in AIAO buildings.

Sow numbers, which was an indicator of farm size, was positively correlated with hygiene levels in the study buildings (Table 19.4). As expected, on larger farms the floor contamination level tends to increase. It has been hypothesized that, on larger farms, because of work pressures, less time is available for cleaning and general maintenance of the pigs' environment. The increased intervals between cleaning episodes create an ideal environment for reduced building hygiene.

Unexpectedly, stocking rate was negatively correlated with hygiene level in grower, finisher and weaner buildings (Table 19.4). However, further analysis demonstrated that this overall effect was heavily influenced by the close relationship between improved hygiene and increasing stocking rate in weaner buildings (data not shown). In grower/finisher building the relationship was

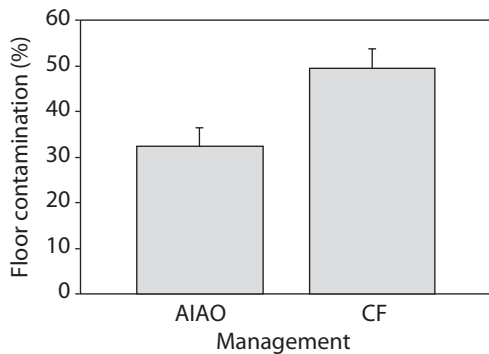

Figure 19.4. Effect of pig management (all-in/all-out, AIAO vs. continuous flow, CF) on floor contamination (%) in Australian piggy buildings (LS means with standard error,  $P < 0.05$ ).

Table 19.4. The effects of covariates on the level of pen floor contamination (%).

Parameter	Covariate	Slope
Pen hygiene	Number of sows (farm size)	Positive
Pen hygiene	Stocking rate (kg pig/m <sup>2</sup> )	Negative

positive indicating that increasing stocking rates will result in greater level of floor contamination. The explanation for these results is not easy, but it could be hypothesised that in weaner buildings the higher stocking rates will result in better self-cleaning of the fully slatted floors, which are typically used in weaner buildings. One of the main benefits of using fully slatted pigpens is to be able to separate the pigs from the excreta. The pigs will ideally deposit and then trample on the excreta forcing it to fall through the slats into a channel or pit below. The success of this system relies on providing conditions that encourage the pigs to trample excrete often, so the floor becomes self-cleaning. Obviously, one of the best ways of achieving this is to increase stocking rates in fully-slatted (weaner) buildings. However, in grower/finisher building the increased stocking rate resulted in reduction in pen hygiene, though this effect was not statistically significant.

### **19.3.2 Study component 2: controlled experiment**

#### *Experiment 1*

In the control pens the correct dunging patterns did not change throughout the experimental period. However, incorrect dunging pattern was observed in the experimental pens soon after the wetting commenced and the level of soiling deteriorated rapidly in these pens (Figure 19.5). The difference in floor contamination level was statistically significant between the experimental (35%) and control pens (5%). The experiment demonstrated that liquid coverage on the pen floor would trigger incorrect dunging. To induce incorrect dunging in pens with established correct dunging patterns requires considerable wetting. However, it was hypothesised that for example spraying oil/water mixture on pen floors, if incorrectly managed could have a longer wetting effect than water alone which can easily evaporate in warm weather (Banhazi, 2005). After spraying pen floors (delivering very large droplets of oil/water mixture) in one dose per day, pens floors could appear to be wet for an extended period which can potentially trigger incorrect dunging patterns. Therefore care has to be taken when spraying or cleaning pen floors to avoid extensive, daily wetting of pen floors in pigpens in order to avoid the deterioration of pen hygiene (Figure 19.5).

The results also demonstrated the need to dry the rooms after cleaning and before re-stocking to avoid the emergence of incorrect dunging patterns in freshly stocked pens. Although, dunging patterns are believed to be influenced by many factors, wet pen flooring is clearly a risk factor.

#### *Experiment 2*

During the first run of the second experiment no significant difference between the treatment and control pens were found (Figure 19.6). Although, the treatment pens remained relatively clean (8%), the control pens also remained dung-free (11%). That experiment highlighted the difficulties involved in studying dunging patterns. It is generally accepted that many, sometimes 'unidentified' factors, influence dunging patterns. Farm experience also proved that sometimes adjoining pens could have different dunging patterns and resultant hygiene levels. The reasons behind the difference are often difficult to explain. Therefore, even under experimental conditions, the results are sometimes difficult to control and predict.

## 19. Modelling and influencing hygiene conditions in Australian livestock buildings

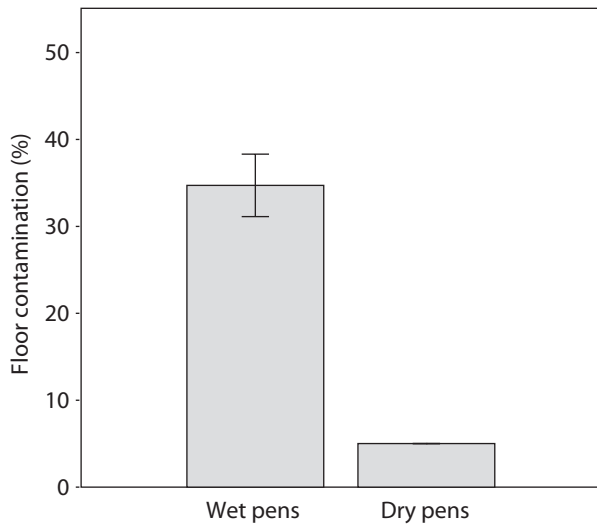

Figure 19.5. Floor contamination level (%) observed in the wet and dry pens during experiment 1. (LS means  $\pm$  standard error,  $P < 0.001$ ).

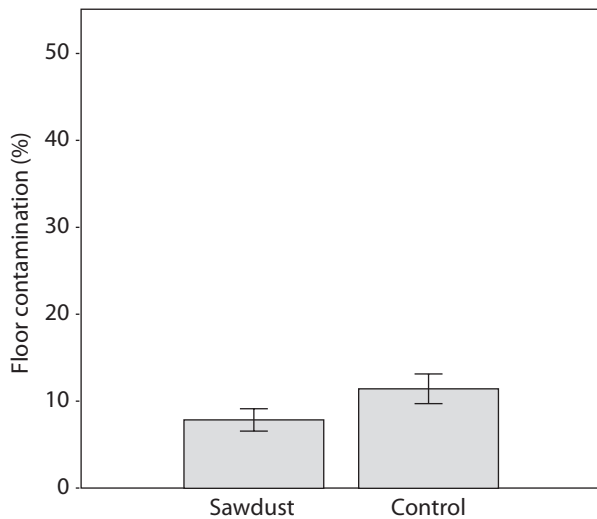

Figure 19.6. Floor contamination level (%) observed in the pens with and without sawdust during experiment 2a. (LS means  $\pm$  standard error,  $P = 0.12$ ).

However, the second run of the second experiment did demonstrate a statistically significant difference between treated (8%) and untreated (40%) pens (Figure 19.7). Overall, sawdust applications can be recommended as a viable management method to influence dunging patterns.

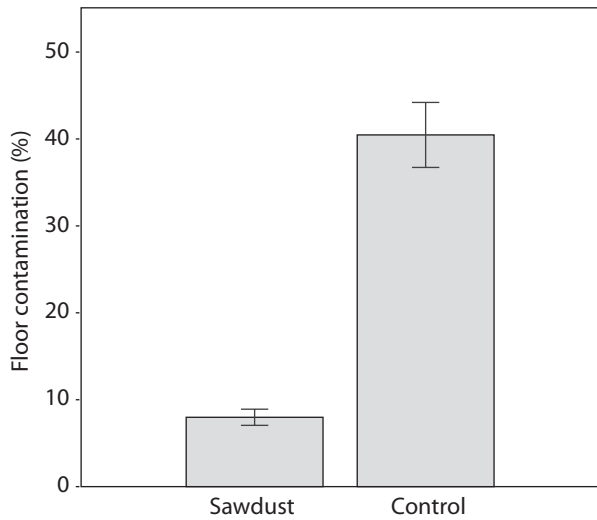

Figure 19.7. Floor contamination level (%) observed in the pens with and without sawdust during experiment 2b. (LS means  $\pm$  standard error,  $P < 0.001$ ).

However, sawdust application might be recommended as a ‘preventative technique’ rather than a problem solving method, as it is highly unlikely to be able to correct existing dunging problems. The application of oily sawdust is preferred rather than dry sawdust to reduce the opportunity of airborne dust generation from the dry bedding material.

### Experiment 3

The third experiment did not prove the positive use of play chains (Figure 19.8), as the contamination level of the solid concreted area significantly increased (45%) when the play chains were placed above the slatted area. Floor contamination level (6%) in pens without chains (control) and in pens where the chains were placed over the solid area remained similar (8%). However, it underpinned claims, that chains can be used to ‘clean-up’ areas where dunging is undesirable (P. Pattison, personal communication). During this experiment the slatted dunging area was ‘cleaned-up’ by forcing the pigs to relocate their ‘toilet’ area to the concreted part of the pen. This effect was clearly undesirable, but proved that fact that too much activity in the designated dunging area will discourage pigs to use the slatted ‘toilet’ area appropriately, as indicated in previous publications (Bate *et al.*, 1988; Petherick, 1982).

One of the limitations of the study was the size and shape of pens used in the study. It has been stated previously by Dutch researchers (P.F.M.M. Roelofs, personal communication) that chains will only work in pens that are correctly designed. It was suggested, that pens should be long and narrow and designed in a way to ensure that there are three clearly identifiable areas exist in the pen, such as dunging, resting and activity/feeding areas. The selection of the dunging and resting

## 19. Modelling and influencing hygiene conditions in Australian livestock buildings

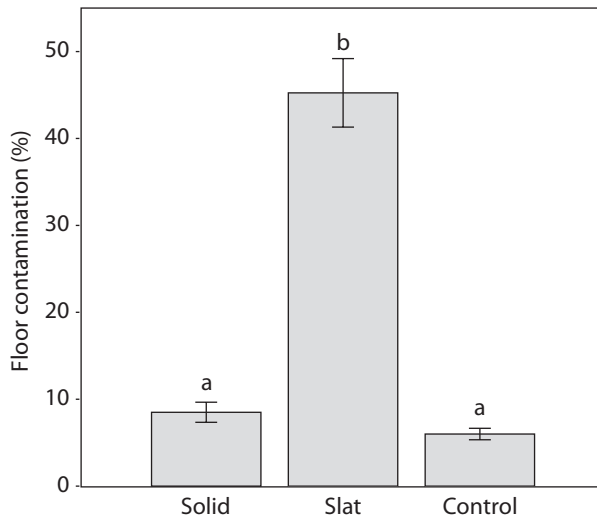

Figure 19.8. Floor contamination level (%) observed as the result of three different treatments during experiment 3. (Different letter above the graph indicates significant difference) (LS means  $\pm$  standard error,  $P < 0.001$ ).

areas is usually interrelated, as pigs are believed to avoid urinating and defecating in places where they eat or rest.

In our study facilities the pens were rather wide and relatively short. Therefore, it was hypothesised that in these types of pens, the activity created over the solid area also disturbed the resting area, forcing some of the pigs to seek isolation in the slatted areas (Figure 19.8). Therefore, reduced amount of slatted areas was available for the pigs to use for dunging, in turn forcing some of them to dung on the concreted areas. Casual behaviour observation of pigs during the trial appeared to support this theory.

Producers need to avoid disturbing both resting and dunging area. It appears that for both resting and dunging area should be 'quiet' places and play chains (if used) need to be located in areas, where the resulting extra movement will not negatively influence the dynamic of the pen and therefore dunging patterns within the pens.

The study also demonstrated that 'negative' interventions influencing dunging behaviour are probably more reliable than 'positive' interventions. Positive interventions aimed at rectifying incorrect dunging patterns might not always yield the expected results. Therefore, it is probably easier to identify management interventions that have to be avoided, rather than management procedures that could be recommended with confidence to create more hygienic pen conditions.

## **19.4 Conclusions**

Our results demonstrated that the correct management of air temperature and stocking rate (SR) are the most practically beneficial ways of improving pen hygiene in piggery buildings. Temperature decrease will have a beneficial effect on pen hygiene in partially slatted pens, but there is a lower limit below which temperature cannot be reduced, as it would interfere with thermal comfort. In the same way, SR cannot be decreased drastically, due to potential negative economic impact. Farm size again cannot be manipulated, as the general trend toward larger farm size is driven mainly by economic considerations. In the same way, seasonal effects have to be accepted, but producers must be aware of the increased risks of reduced pen hygiene associated with summer periods.

All these and potentially other factors must be taken into consideration, as practical experience demonstrated that dunging patterns are influenced by the combination of many factors under commercial conditions. Only through careful management and design of pigpens will correct dunging patterns be achieved. Care must be taken when designing and importantly managing the buildings and pens to create a pen environment that is suitable for the development of correct dunging patterns.

The controlled experiments demonstrated that wet pen floors are clearly a risk factor for the development of incorrect dunging patterns, but saw dust might be used to positively influence dunging behaviour. Play-chains might also be used effectively to influence dunging behaviour, however the use of this technique can only be recommended in pens with a suitable design.

## **Acknowledgements**

This modelling study and the previous study used for data collection were both funded by Australian Pork Limited. The data collection component of the study was undertaken as a large collaborative project between the South Australian Research and Development Institute, Agriculture Western Australia, Agriculture Victoria, and the Queensland-based Swine Management Services. Both projects involved the contributions of many individuals, and we wish to particularly acknowledge the contributions of the pig producers involved in the study. We also would like to sincerely thank Dr. C. Cargill, who was instrumental in obtaining funding for the data collection project; Dr. J. Black, Dr. W. Pitchford, Dr. D. Rutley and Prof. J. Hartung for their professional advice; and Dr. S. Dreisen, Dr. G. Marr, and Mr. H. Payne for their efforts of coordinating the data collection in different states. The important contributions of all technical officers (Mr. R. Nichol, Ms. S. Koch, Mr. P. Daniels, Mr. J. Weigel, Mr. S. Szarvas, and Ms. A. Kefford) involved in the survey and the technical assistance provided by K. Hillyard and T. Murphy during the controlled experiments are also gratefully acknowledged.

### References

- Aarnink, A.J.A., Schrama, J.W., Verheijen, R.J.E. and Stefanowska, J., 2000. Effect of ambient temperature on pen fouling by pigs. 10<sup>th</sup> International Congress on Animal Hygiene, Maastricht, the Netherlands, pp. 933-937.
- Aarnink, A.J.A., Schrama, J.W., Verhijen, R.J.E. and Stefanowska, J., 2001. Pen fouling in pig houses affected by temperature. *Livestock Environment VI*, May 21-23, Louisville, Kentucky. The Society for engineering in agricultural, food, and biological systems, pp. 180-186.
- Aarnink, A.J.A., Swierstra, D., van den Berg, A.J. and Speelman, L., 1997. Effect of type of slatted floor and degree of fouling of solid floor on ammonia emission rates from fattening piggeries. *Journal of Agricultural Engineering Research* 66: 93-102.
- Aarnink, A.J.A., Van den Berg, A.J., Keen, A., Hoeksma, P. and Versteegen, M.W.A., 1996. Effect of slatted floor area on ammonia emission and on the excretory and lying behaviour of growing pigs. *Journal of Agricultural Engineering Research* 64: 299-310.
- Banhazi, T., 2005. Oil spraying systems for piggeries to control dust. In: Fahy, T. (ed.) *Proceedings of AAPV Conference, AVA, Gold Coast, QLD, Australia*, pp. 76-80.
- Banhazi, T., Murphy, T., Hillyard, K. and Kloppers, M., 2002. The effects of a wet floor on dunging patterns. In: Revell, D.K. and Taplin, D. (eds.) *Animal production in Australia, ASAP, QLD, Australia*, p. 372.
- Banhazi, T.M., Rutley, D.L. and Pitchford, W.S., 2010. Validation and fine-tuning of a predictive model for air quality in livestock buildings. *Biosystems Engineering* 105: 395-401.
- Banhazi, T.M., Seedorf, J., Rutley, D.L. and Pitchford, W.S., 2008a. Identification of risk factors for sub-optimal housing conditions in Australian piggeries – Part I: study justification and design. *Journal of Agricultural Safety and Health* 14: 5-20.
- Banhazi, T.M., Seedorf, J., Rutley, D.L. and Pitchford, W.S., 2008b. Identification of risk factors for sub-optimal housing conditions in Australian piggeries – Part II: airborne pollutants. *Journal of Agricultural Safety and Health* 14: 21-39.
- Bate, L.A., Hacker, R.R. and Phillips, P.A., 1988. Effect of growth on porcine defecation patterns. *Canadian Agricultural Engineering* 30: 191-192.
- Baxter, M.R., 1982. Environmental determinants of excretory and lying areas in domestic pigs. *Applied Animal Ethology* 9: 195.
- Hacker, R.R., Ogilvie, J.R., Morrison, W.D. and Kains, F., 1994. Factors affecting excretory behavior of pigs. *Journal Of Animal Science* 72: 1455-1460.
- Olsen, A.W., Dybkjaer, L. and Simonsen, H.B., 2001. Behaviour of growing pigs kept in pens with outdoor runs: II. Temperature regulatory behaviour, comfort behaviour and dunging preferences. *Livestock Production Science* 69: 265-278.
- Petherick, J.C., 1982. A note on the space use for excretory behaviour of suckling piglets. *Applied Animal Ethology* 9: 367-371.
- Randall, J.M., 1980. Selection of piggery ventilation systems and penning layouts based on the cooling effects of air speed and temperature. *Journal of Agricultural Engineering Research* 25: 169-187.
- Randall, J.M., Armsby, A.W. and Sharp, J.R., 1983. Cooling gradients across pens in a finishing piggery. II. effects on excretory behaviour. *Journal of Agricultural Engineering Research* 28: 247-259.
- SAS, 1989. *SAS/STAT® User's Guide, Version 6, Fourth Edition, Volume 2*, SAS Institute, Cary, NC, USA.
- Simonsen, H.B., 1990. Behaviour and distribution of fattening pigs in the multi-activity pen. *Applied Animal Behaviour Science* 27: 311-324.
- StatSoft, I., 2001. *STATISTICA*. StatSoft, Inc., Tulsa, OK, USA.



## **T. Banhazi**

- Takai, H., Pedersen, S., Johnsen, J.O., Metz, J.H.M., Groot Koerkamp, P.W.G., Uenk, G.H., Phillips, V.R., Holden, M.R., Sneath, R.W., Short, J.L., White, R.P., Hartung, J., Seedorf, J., Schroder, M., Linkert, K.H. and Wathes, C.M., 1998. Concentrations and emissions of airborne dust in livestock buildings in Northern Europe. *Journal of Agricultural Engineering Research* 70: 59-77.
- Turner, J.D. and Lockhart, R., 1987. Observation on pig lying and dunging behaviour in finishing pens incorporating a raised slatted dunging area. *Occasional Publications No. 11 – British Society of Animal Production*: 142.
- Wechsler, B. and Bachmann, I., 1998. A sequential analysis of eliminative behaviour in domestic pigs. *Applied Animal Behaviour Science* 56: 29-36.
- Watson, T.S., 1978. The development of dunging preference in piglets. *Applied Animal Ethology* 4: 293.
- Watson, T.S., 1985. Development of eliminative behaviour in piglets. *Applied Animal Behavior Science* 14: 365-377.

## **Part 7**

# **Technological tools for managing livestock facilities**



## 20. Towards an automatic dairy cattle welfare monitoring

V. Poikalainen, E. Kokin, I. Veermäe and J. Praks  
Estonian University of Life Sciences, Kreutzwaldi 1, 51014 Tartu, Estonia;  
[vaino.poikalainen@emu.ee](mailto:vaino.poikalainen@emu.ee)

### Abstract

Welfare automatic monitoring gives many novel opportunities to milk producers for management and care of dairy cows. In this article monitoring possibilities of welfare connected parameters (housing environment, production, reproduction, health, etc.) in cowsheds having management information systems are described. Some problems of data acquisition are discussed. Computer and measurement systems network for data exchange within cowshed and via internet is proposed. Basic principles of data and inputs selection for model structure build-up based on Welfare Quality® system are suggested.

**Keywords:** livestock, health, sensor, data acquisition, model, network, PLF

### 20.1 Introduction

Traditionally the welfare and health of dairy cows has been monitored by observation of skilled stockperson and veterinarian, using changes in performance, behaviour (motion activity, lying behaviour, etc.), physiological parameters (temperature, heart rate, etc.) and detecting signs of disease (e.g. lameness).

Cattle welfare can be assessed in a scientific way using different parameters and a combination of methods. It is possible to divide parameters characterising animal welfare into two groups:

- parameters of housing environment;
- animal-based parameters (behaviour, health, physiology).

For the assessment of welfare and to accommodate the information requirements of consumers different systems have been developed (Praks *et al.*, 2011). The Bristol Welfare Assurance Programme (Webster, 2004) and Welfare Quality® Project (Anonymous, 2009) use for the welfare status assessment mainly animal-based measures, which give more adequate results of existing welfare situation. Environment-based parameters can be used for potential improvements of animal welfare.

Living organisms have always been considered as too complex to be monitored and controlled in automatic way, but new emerging technologies offer possibilities to develop on-line means for that (Berckmans, 2004; Wathes *et al.*, 2008).

Nowadays the intensive automation of the technological processes in the loose housing of cows develops very rapidly all over the world (robot milking, manure removing, etc.). As automation reduces contact between humans and animals to minimum, opportunities to determine the behaviour, health and welfare of individual animals decline. It means that acquisition and analysis

of data concerning an individual animal and its surrounding environment at farms (building and indoor climate, feeds and feeding, farming technology, diseases, etc.) have obtained very important position in animal husbandry.

The principles and possibilities of automated monitoring of dairy cows welfare in loose housing cowsheds will be considered as elements of precision livestock farming (PLF).

## 20.2 Concept of automatic cows' welfare evaluation

Welfare status of dairy cattle is influenced directly by housing environment. Knowing the cow's reaction to that influence (by change in milk yield and composition, physiological reactions, behaviour, etc.), it becomes possible to estimate welfare status and changes of that (Figure 20.1).

To make the system for automatic welfare evaluation functional it should meet five main conditions: (1) cows should be identified automatically; (2) monitoring and registering of housing environment parameters should be carried out; (3) monitoring of cow's behaviour, physiological parameters, production level and other animal-based parameters reflecting welfare status should be performed; (4) software for processing and interpretation of obtained data and models for welfare estimation should exist; and (5) data of housing environment, animal-based parameters, diseases as well as welfare score should be kept in a database and complemented in real time.

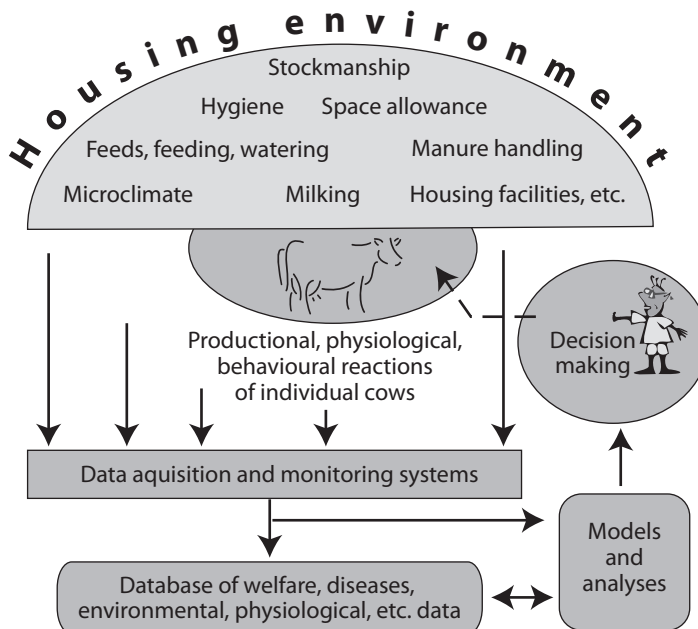

Figure 20.1. Concept of automatic cow's welfare evaluation.

Fully automatic control (common in PLF) to improve welfare within the system is possible for some parameters only (e.g. indoor climate). In other cases for decision making and control of welfare participation of man is needed, that is obligatory especially in diagnosing and medical treatment.

### 20.3 Essential animal-based parameters for automatic acquisition

Several computer based systems for data acquisition have been developed and already utilized by dairy equipment producers (e.g. DeLaval Herd Navigator, DeLaval, Lely and Westfalia milking robots, Boumatics StepMetrix walk-through scales, etc.), but the research for improvement of existing systems and elaboration of novel ones continues constantly. In Table 20.1 the list of automatically collectable animal-based welfare parameters is given, their explanation follows the table.

Table 20.1. Animal-based parameters for automatic acquisition at loose housing.

No	Measurable and calculable parameters	Measurement place <sup>1</sup>	Application domain	Development status
1	Milk temperature	MP, MR	health, oestrus	conventional
2	Milk conductivity	MP, MR	udder health, breeding	conventional
3	Milk colour	MP, MR	udder health	novel
4	Milk homogeneity	MP, MR	udder health	novel
5	Milk composition: lactose, protein, fat, progesterone, lactate dehydrogenase, urea, beta hydroxyl butyrate	MP, MR	udder health, nutrition, reproduction, udder health, nutrition, ketosis, metabolic disorders	novel, pilot
6	Somatic cells count	MP, MR	udder health	novel
7	Milk yield, flow, milking time	MP, MR	health, nutrition	conventional
8	Milking frequency	MR	behaviour, health	novel
9	Milking order	MP	behaviour, health	pilot
10	Body temperature	MP, MR, AS	health, oestrus	conventional
11	Heart rate	AS	health	novel, pilot
12	Respiration rate	MR, CF	health	pilot
13	Intake	MP, MR, CF, FA	health, nutrition	novel, pilot, conventional
14	Rumination	AS	health, nutrition	novel, pilot
15	Body weight	MR, CF, WA	health, nutrition	conventional
16	Body condition score	WA	health, nutrition	novel, pilot
17	Animal activity	AS, WA	behaviour, health, oestrus	novel, pilot, conventional

<sup>1</sup> MP: milking parlour; MR: milking robot; AS: sensors attached to the animal; CF: concentrate feeder; FA: feeding area; WA: walking area.

Traditionally different milk parameters have been used for milk quality estimation. Such milk physical parameters as temperature, electrical conductivity, colour and homogeneity may be utilized for assessment of welfare, mainly udder health.

- Milk temperature has been measured by temperature sensors placed in different parts of the milking system. Significant positive correlation existed between milk and body temperature (Fordham *et al.*, 1987; Poikalainen, 1999).
- Milk electrical conductivity (EC) is measured mainly by two types of commercially available systems – for the whole milk or per udder quarter. EC measurements on quarter level increase accuracy of mastitis diagnosis (Mollenhorst, 2010). Collecting and implementing EC information in breeding programs may be useful (Norberg, 2005).
- Milk colour has been estimated by reflection or transmission of light, and milk homogeneity – by image processing or diffusing wave spectroscopy. In combination with other parameters these may be used for the mastitis detection (Hogeveen *et al.*, 2010).
- Milk chemical composition is used to monitor reproduction, mastitis, energy and protein balance. Basic components of milk (protein, fat and lactose) are measured by near-infrared spectroscopic methods. The techniques for lactate dehydrogenase, urea and beta hydroxyl butyrate measurements are based on a colorimetric principle, the progesterone determination – on an immunoassay (Mazeris, 2010) or by near-infrared spectroscopic sensing system (Kawasaki *et al.*, 2008).
- Milk somatic cell count (SCC) is good indicator for detection of mastitis. Measuring SCC on quarter level gives better results than on whole milk level. Sensors that measure SCC on-line, based on the principles of the Californian Mastitis Test or on counting the actual number of cells optically, are commercially available. The near-infrared spectroscopic sensing system has also shown the ability to measure SCC in raw milk (Hogeveen *et al.*, 2010; Kawasaki *et al.*, 2008).
- Milk yield, flow and milking time are important items too. Different types of milk meters have been elaborated (Ordloff, 1989). The more recent measurements of these parameters on udder quarter level give more valuable information about udder health.
- Milking frequency is recorded by milking robot, milking order – at milking parlour. Milking frequency has been rarely used as an indicator of welfare until present time. Stable ranking order exists inside the cows' groups in entering the milking parlour. Preliminary analysis showed that cows with health problems stay more backwards. In this way monitoring of milking order could be a PLF tool for welfare estimation (Polikarpus *et al.*, 2011).
- Increase in body temperature is an early sign for many diseases and oestrus. Cattle body temperature can be automatically measured at various anatomical locations (ear, reticulum-rumen, udder, etc.) directly or indirectly using different means (Poikalainen, 1999, Bewley and Schutz, 2010). Monitoring devices attached for example, in the cow's ear and integrating measurements of body temperature and movements are developed. This information, combined with other cow data may be used for generation of alerts indicating cows needing extra attention.
- Traditionally the heart rate, characterising health and behaviour, has been estimated using plethysmographic and electrocardiographic means. For automatic cattle heart rate determination an electrocardiographic pill has been developed (Warren *et al.*, 2008).
- To monitor the respiration rate by registration of body surface movement with laser-based measuring equipment is proposed (Pastell *et al.*, 2006).

## 20. Towards an automatic dairy cattle welfare monitoring

- Individual concentrate feeders allow discovering changes in routine eating pattern by analysing the visiting frequency and intake. These can be estimated also by monitoring the position of animals and the time spent at the feeding table. Automatic wireless cow tracking system can be used for that (Huhtala *et al.*, 2007).
- Rumination in dairy cattle associates with saliva production and rumen health. The rumination can serve both in nutrition management and welfare monitoring. Rumination monitoring systems based on analysis of sounds picked up by a microphone have been developed (Bar and Solomon, 2010; Maltz, 2010).
- Changes in live weight of dairy cattle could serve as useful information for both the diagnosis of health problems and for feeding management. Different static and dynamic walk-through scales are commercially available for that.
- The Body Condition Score allows the nutritional status, energy reserves and health monitoring of the dairy cow (Bewley and Schutz, 2008). An automated system that calculates the body condition score and body weight using an image processing technique has been developed (Velmurugan *et al.*, 2010).
- The locomotion activity can be used for monitoring of behaviour, especially for estimation of oestrus and leg disorders. The assessment of insemination optimal time is performed by different pedometers for 25 years already. Modern devices use accelerometric technique. These can also include on-board controller that analyses walking, lying, getting up and down, and head movements (Durkin, 2010). Such intelligent loggers may include also other measurement systems, e.g. for temperature recording (Brehme *et al.*, 2008).

For complex welfare measures and criteria estimation needing analysis of several input parameters some specific modules should be implemented, for example for leg disorders monitoring.

### 20.4 Overview of specific modules for lameness estimation

Lameness of dairy cows has been classified as very important welfare problem at loose housing. With increasing herd size the need for an objective, automatic lameness scoring grows considerably (Anonymous, 2001; Berckmans, 2004; Kokin *et al.*, 2007; Poikalainen *et al.*, 2004).

Automatic detection of clinical symptoms of leg disorders using a set of static scales has been elaborated in cooperation of Finnish and Estonian researchers (Pastell *et al.*, 2005, 2006a,b; Poikalainen *et al.*, 2004). A four balance system for measuring dairy cow leg load distribution in a milking robot has given promising results. With neural network model it was possible to classify 96.2% of the measurements correctly as sound or lame cows (Pastell and Kujala, 2007; Pastell *et al.*, 2008). At concentrate feeders the use of four-balance system is complicated but the analysis of only rear leg load distribution can be implemented (Poikalainen *et al.*, 2011). To improve lameness estimation the weight distribution, lying time and walking speed may be combined (Chapinal *et al.*, 2010).

For cows' gait registration and analysis four basic approaches are suggested – using walk-through scales, systems with pressure sensitive walk-over mats, automatic analysis of video-signals, and activity monitoring using accelerometric systems.



Walk-through scales, based on vertical ground reaction force measurements of individual limbs were elaborated and are available commercially. Vertical forces measured over time with two parallel force plates are used to calculate a number of limb movement variables. To separate the results of individual animal within a group walking through the system special algorithm was developed (Rajkondawar *et al.*, 2001, 2006).

The preliminary research of using mats with sensors responding to the foot pressure has been carried out by different groups (Maertens *et al.*, 2007; Pastell *et al.*, 2008). At the University of Helsinki and Estonian University of Life Sciences a walk-over mat with quasi-piezoelectric sensors was tested for automatic cows' gait registration (Poikalainen *et al.*, 2010).

Research has proved that automatic use of video signals has great potential to be used for continuous monitoring of lameness. The automatic lameness detection methods by vision analysis of feet movement and back curve were elaborated. To separate the individual cow data within a group an algorithm was proposed based on image filtering and statistical analysis. A strong linear regression exists between locomotion score given by automatic system and by experts (Maertens *et al.*, 2007; Pluk *et al.*, 2009; Poursaberi *et al.*, 2009, 2010; Song *et al.*, 2008).

Accelerometric systems monitoring locomotion activity, lying and standing behaviour can be used for lameness estimation also (Alsaad and Büscher, 2011). However, their accuracy is not as good as in case of gait registration systems described above. It can be improved using three-dimensional accelerometers especially when attached to a leg (Chapinal *et al.*, 2010, 2011). Good results were achieved by wireless accelerometric system (Pastell *et al.*, 2009).

## **20.5 Principal structure of an automatic welfare monitoring system**

An overall welfare monitoring system should integrate in reasonable way a wide set of different hardware and software to cover most important factors influencing cows' welfare. Currently basics of animal welfare evaluation are in transition phase whereas former environmental-based systems are replaced by animal-based ones (Anonymous, 2009; Praks *et al.*, 2011). Therefore the structure of data acquisition should be universal but handling of data quite flexible and changeable according to addition of new scientific knowledge. Three main groups of data should be considered in acquisition sub-systems which are interfacing with each other. These are: (1) data stored in the cowshed management information system (MIS); (2) data from housing environment monitoring sub-systems; and (3) data from additional modules for physiological and behavioural monitoring (Figure 20.2).

Existing management information systems for dairy cattle housing incorporate automatic identification of animals and quite a lot of means for registering housing conditions, individual productivity, reproduction, etc., and databases for keeping records. Usually also some cow-specific physiological parameters are recorded by MIS, for example body temperature, milk conductivity, animal activity. Means for that are constantly made better and more reliable. Data acquisition systems for on-line automatic estimation of milk composition and quality, body weight and body condition are currently elaborated (Table 20.1).

## 20. Towards an automatic dairy cattle welfare monitoring

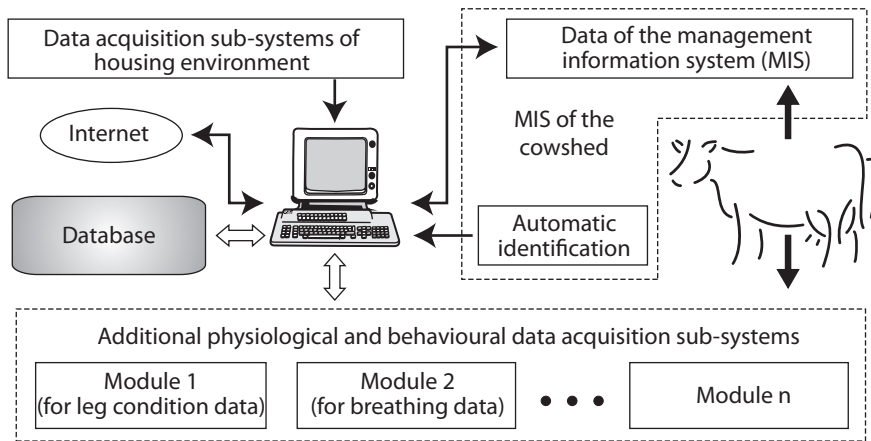

Figure 20.2. Principal structure of an automatic system for welfare monitoring of cows.

For monitoring of housing environment, especially indoor climate, a number of equipment is commercially available. Using these, air temperature, air humidity, air velocity, and lighting can be measured and stored in a database (Figure 20.3). For registration of concentration of carbon dioxide, ammonia, and other noxious gases digital controller-based specific systems are also produced (Teye *et al.*, 2008). Integration of indoor climate parameters into common monitoring system is comparatively easy task because standardized protocols for data exchange can be used.

Additional data acquisition systems for cows' physiological and behavioural parameters are reasonable to elaborate as autonomous modules with universal interface for data exchange. Examples of these are various sub-systems for lameness estimation, breathing frequency registration, heart rate registration and analysis, etc. (Table 20.1). These sub-systems will gradually be integrated into MIS as their reliability, efficiency and price will become acceptable for milk producers.

A lot of useful data about cows is collected and stored into collective databases, especially for breeding proposes and health control. For example, Estonian Animal Recording Centre collects monthly data of productivity, milk composition and SCC, reproduction and disease incidences, main parameters of heredity. All these can be used for automatic evaluation of welfare. To enable that the possibilities for data exchange via internet and local network should be foreseen. Specific means for manual data input (e.g. part of the information concerning health status is entered manually) and for experimentation control are needed also.

An important factor of automatic welfare monitoring is arrangement of data exchange between different parts of the integrated system. This is influenced by: (1) structure of the network; (2) unification of the interfaces and protocols; and (3) MIS openness for data exchange.

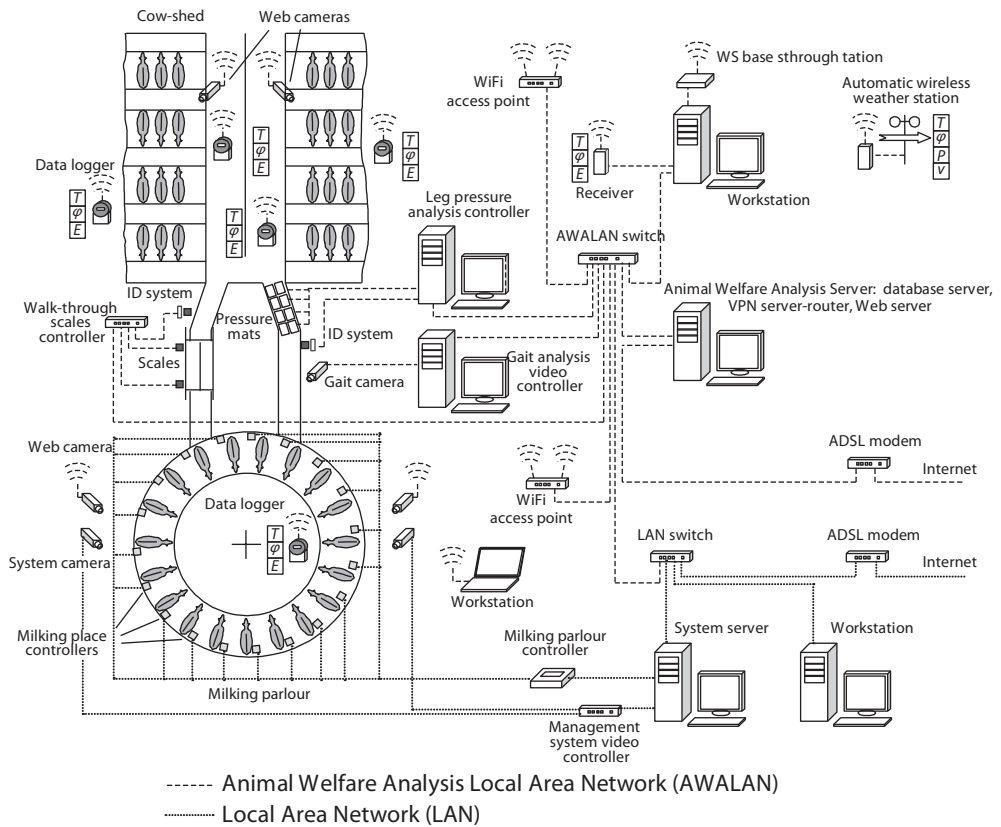

Figure 20.3. Configuration example of local area and welfare analysis networks for the cowshed.

To enable connectivity of existing and new measurement and analysis equipment within the system the most important element of it is data exchange network. The amount of the information that should be transported in this network will be increasing with addition of new elements and the information exchange speed may become of great importance, especially in case of video data analysis (e.g. gait video analysis).

For research purposes it would be desirable to have access not only to the controllers' output data, representing results of some analysis, but to the raw measurement data also. Such network should be partially wired and partially wireless.

Taking into account all these aspects we suggest currently that the network incorporating all measurement elements and delivering data to the computer based controllers should be of Ethernet type. Ideally that means that all measurement transducers and controllers should have standard Ethernet interface and thus be accessible by any element in the system for data transfer. The addressing of all devices and data exchange will be possible using TCP/IP protocol. Standard

## 20. Towards an automatic dairy cattle welfare monitoring

Ethernet supports 100 to 1000 megabit per second data rates which are orders of magnitude more bandwidth than most existing industrial field buses.

Differently from most other types of networks, especially those used by well-known farm equipment producers, using of Ethernet-based industrial network protocols opens up the possibilities for the third-party producers and researchers to develop devices that can be added to the network as it is more transparent and less producer-specific. Also, the raw information of all systems is comparatively easily accessible and browser-based monitoring for remote configuration and maintenance is available.

The connection of the existing local area network (LAN) of the farm and the animal welfare analysis network (AWALAN) in this case is elementary and the only problem is the openness of the MIS database for retrieval of the data needed by the animal welfare analysis software for combining it with the measurement data of the AWALAN.

The example of possible configuration of local measurement and information exchange system usable for experimentation is shown in Figure 20.3 (Kokin *et al.*, 2007). Three different lameness automatic detection systems are shown: leg pressure analysis system with quasi-piezoelectric sensor mats (Pastell *et al.*, 2008); walk-through scales (Rajkondawar *et al.*, 2006) and gait video analysis system (Poursaberi *et al.*, 2010). Administration of data exchange in and between AWALAN and LAN is maintained by server computer (analysis server) that has a role of VPN server-router to provide access to AWALAN and LAN by remote workstations (e.g. for researchers, farm administrators), database server and also web server for web and system cameras, weather stations, milking and other systems output depending on the homepage design.

The main role of the analysis server though is to acquire all necessary data from AWALAN, MIS and remote information databases accessible by the internet to assess the welfare state and its changes in time for individual animals on the farm using specific models for necessary welfare criteria analysis. The results of the analysis may be used for prediction of situations needing attention and for issuing warnings to a farmer.

These tasks will be carried out by software models. Algorithms of these models are based on various mathematical theories and scientific investigations to estimate influence of different factors as input parameters and interactions of these with welfare status. Number of these factors is usually large and interactions are versatile. To determine all ties would be extremely complicated task. Therefore for analysis the probabilistic approach is used. Most commonly it is based on probabilistic neural network analysis, Bayesian network, Markov chain analysis, etc. To make programming of models easier various special software design packages can be implemented (MatLab, Scilab, etc.).

More complicated models consist of several sub-models which interact in a certain way. This approach is necessary in monitoring of the welfare too. Creation of a model starts with mapping of inputs. For instance, indicators of leg problems are: reduced locomotion activity, reduction of milk yield, increasing body temperature, decreasing load on disordered leg, change in gait pattern, etc. Cow body temperature, performance, activity data can be used as inputs for model of

mastitis or udder health in general. More specific parameters for mastitis estimation are EC and SCC of milk (Table 20.1). These inputs may be recorded by different measurement systems or be outputs of MIS database (body temperature, performance), or some sub-models. Measurement systems for SCC and milk composition are currently worked out (Table 20.1). But for model of mastitis these data can be obtained from collective databases also, using internet and LAN of the cowshed (Figure 20.3 and 20.4).

For ‘calibration’ of models special studies with participation of experienced veterinarians is obligatory. This enables estimation of sensitivity and specificity (false positive and false negative trials) of the model also.

General welfare model build-up should be based on certain welfare evaluation schema. For instance Welfare Quality® system proposed recently utilizes over 30 on-farm measures which give value judgements for 12 different welfare criteria. These criteria are base for description of four independent welfare dimensions to estimate overall welfare status. Approximately the same structure should be applied for welfare modelling. This leads to a set of different models arranged into hierarchic structure (Figure 20.5).

### 20.6 Concluding remarks

Automatic welfare assessment of dairy cows is a very complicated task that needs a lot of efforts in data acquisition, exchange and handling. But solving of these problems will enable:

1. to efficiently control the welfare in milk production units;
2. to lessen losses caused by diseases;
3. to optimize management and productivity of cows;
4. to make welfare a driving force for novel applications in food production chain (traceability, labelling);
5. to build up regional, national and international computerized networks for welfare control.

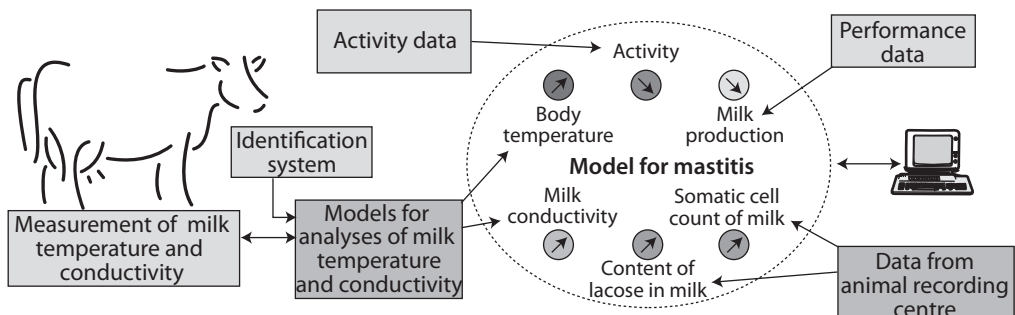

Figure 20.4. Concept of automatic evaluation of mastitis.

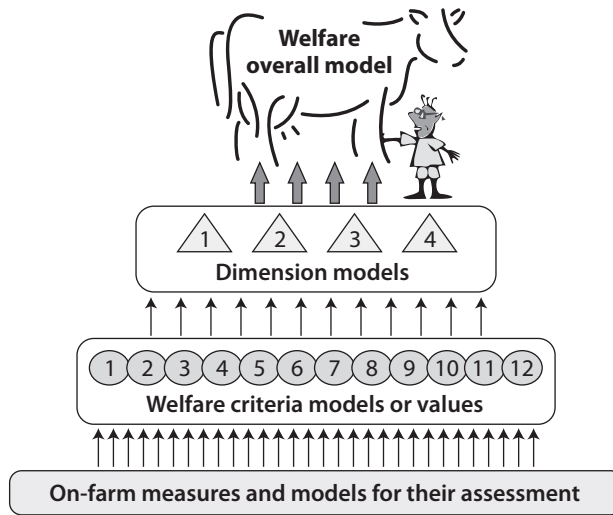

Figure 20.5. Proposed set of models for automatic welfare assessment based on Welfare Quality® system.

## Acknowledgements

This research was supported by the Estonian Science Foundation grant 7518, Targeted Finance Project SF0170165s08 and project ‘Elaboration of automatic monitoring system for detection of cattle leg disorders’.

## References

- Alsaad, M. and Büscher, W., 2011. Sensor based lameness detection in dairy cows through measuring pedometric activity and lying behaviour. In: Köfer, J. and Schobesberger, H. (eds.) Animal hygiene and sustainable livestock production. Proceedings of the XV ISAH Congress 3-7 July, Vienna, Austria, pp. 321-323.
- Anonymous, 2001. Scientists’ assessment of the impact of housing and management on animal welfare. *Journal of Applied Animal Welfare Science* 4(1): 3-52.
- Anonymous, 2009. Welfare Quality® assessment protocol for cattle. Welfare Quality® Consortium, Lelystad, the Netherlands, 182 pp.
- Bar, D. and Solomon, R., 2010. Rumination collars: what can they tell us. The First North American Conference on Precision Dairy Management 2010. Toronto, Canada, 2-5 March 2010 Available at: <http://www.precisiondairy2010.com/proceedings/s11bar.pdf>.
- Berckmans, D., 2004. Automatic on-line monitoring of animals by precision livestock farming. In: Madec, F. and Clement, G. (eds.). Animal production in Europe: the way forward in a changing world. In between Congress of the ISAH Proceedings 1. Saint-Malo, France, pp. 27-30.
- Bewley, J.M. and Schutz M.M., 2008. Review: an interdisciplinary review of body condition scoring for dairy cattle. *The Professional Animal Scientist* 24: 507-529.

- Bewley J. and Schutz M., 2010. Recent studies using a reticular bolus system for monitoring dairy cattle core body temperature. The First North American Conference on Precision Dairy Management 2010. Toronto, Canada. Available at: <http://www.precisiondairy2010.com/proceedings/s11bewley.pdf>.
- Brehme, U., Stollberg, U., Holz, R. and Schleusener, T., 2008. ALT pedometer – new sensor-aided measurement system for improvement in oestrus detection. *Computers and Electronics in Agriculture* 62: 73-80.
- Chapinal N., Pastell, M., Hänninen, L., Munksgaard, L., Rushen, J. and De Passillé, A., 2010. Walking acceleration patterns as a method for lameness detection. The First North American Conference on precision dairy management 2010. Toronto, Canada. Available at: <http://www.precisiondairy2010.com/proceedings/s6pastell.pdf>.
- Chapinal, N., De Passille, A., Pastell, M., Hänninen, L., Munksgaard, L. and Rushen, J., 2011. Measurement of acceleration while walking as an automated method for gait assessment in dairy cattle. *Journal of Dairy Science* 94(6): 2895-2901.
- Durkin, J., 2010. Heat detection: trends and opportunities. The first North American conference on Precision Dairy Management 2010. Toronto, Canada. Available at: <http://www.precisiondairy2010.com/proceedings/s5durkin.pdf>.
- Fordham, P., McCarthy, T. and Rowlinson, P., 1987. An evaluation of milk temperature measurement for detecting oestrus in dairy cattle I. Factors affecting measurement of milk temperature. *Veterinary Research Communications* 11(4): 367-379.
- Hogeveen, H., Kamphuis, C., Steeneveld, W. and Mollenhorst, H., 2010. Sensors and clinical mastitis – the quest for the perfect alert. *Sensors* 10: 7991-8009.
- Huhtala, A., Suhonen, K., Mäkela, P., Hakojärvi, M. and Ahokas, J., 2007. Evaluation of instrumentation for cow positioning and tracking indoors. *Biosystems Engineering* 96(3): 399-405.
- Kawasaki, M., Kawamura, S., Tsukahara, M., Morita, S., Komiya, M. and Natsuga, M., 2008. Near-infrared spectroscopic sensing system for on-line milk quality assessment in a milking robot. *Computers and Electronics in Agriculture* 63: 22-27.
- Kokin, E., Veermäe, I., Poikalainen, V., Praks, J., Pastell, M., Ahokas, J. and Hautala, M., 2007. Environment, health and welfare monitoring in precision livestock farming of dairy cattle. In: Cox, S. (ed.) *Precision Livestock Farming '07*. Wageningen Academic Publishers, Wageningen, the Netherlands, pp. 171-177.
- Maertens, W., Baert, J., Vangayte, J., Vranken, E., Berckmans, D. and Sonck, B., 2007. Acquisition techniques for dairy cow gait analysis. In: Cox, S. (ed.) *Precision Livestock Farming '07*. Wageningen Academic Publishers, Wageningen, the Netherlands, pp. 133-140.
- Maltz, E., 2010. Novel technologies: sensors, data and precision dairy farming. The first North American conference on precision dairy management 2010. Toronto, Canada. Available at: <http://www.precisiondairy2010.com/proceedings/s9maltz.pdf>.
- Mazeris, F., 2010. DeLaval herd navigator: proactive herd management. The first North American conference on precision dairy management 2010. Toronto, Canada. Available at: <http://www.precisiondairy2010.com/proceedings/s1mazeris.pdf>.
- Mollenhorst, H., Van der Tol, P.P.J. and Hogeveen, H., 2010. Somatic cell count assessment at the quarter or cow milking level. *Journal of Dairy Science* 93: 3358-3364.
- Norberg, E., 2005. Electrical conductivity of milk as a phenotypic and genetic indicator of bovine mastitis: a review. *Livestock Production Science* 96: 129-139.
- Ordolf, D., 1989. Investigations on the design of floats to control milk meters. *Journal of Agricultural Engineering Research* 43: 113-123.



## 20. Towards an automatic dairy cattle welfare monitoring

- Pastell, M., Takko, H., Hautala, M., Poikalainen, V., Praks, J., Veermäe, I. and Ahokas, J., 2005. Monitoring cow health in a milking robot. In: Cox, S. (ed.) Precision Livestock Farming '05. Wageningen Academic Publishers, Wageningen, the Netherlands, pp. 187-192.
- Pastell, M., Takko, H., Grohn, H., Hautala, M., Poikalainen, V., Praks, J., Veermäe, I., Kujala, M. and Ahokas, J., 2006a. Assessing cows' welfare: weighing the cow in a milking robot. *Biosystems Engineering* 93: 81-87.
- Pastell, M., Aisala, A.-M., Hautala, M., Poikalainen, V., Praks, J., Veermäe, I. and Ahokas, J., 2006b. Contactless measurement of cow behaviour in a milking robot. *Behaviour Research Methods* 38(3): 479-486.
- Pastell, M. and Kujala, M., 2007. A Probabilistic neural network model for lameness detection. *Journal of Dairy Science* 90(5): 2283-2292.
- Pastell, M., Kujala, M., Aisala, A.-M., Hautala, M., Poikalainen, V., Praks, J., Veermäe, I. and Ahokas, J., 2008. Detecting cow's lameness using force sensors. *Computers and Electronics in Agriculture* 64: 34-38.
- Pastell M., Tiusanen J., Hakojärvi M. and Hänninen L., 2009. A wireless accelerometer system with wavelet analysis for assessing lameness in cattle. *Biosystems Engineering* 104: 545-551.
- Pluk, A., Bahr, C., Maernets, W., Veermäe, I., Kokin, E., Praks, J., Poikalainen, V., Pastell, M., Ahokas, J., Van Nuffel, A., Vangeyte, J., Snock, B. and Berckmans, D., 2009. Approach to model based motion scoring for lameness detection in dairy cattle. In: Lokhorst, C. and Groot Koerkamp P.W.G (eds.) Precision livestock farming '09. Wageningen Academic Publishers, Wageningen, the Netherlands, pp. 357-362.
- Poikalainen, V., 1999. Lehma kehatemperatuur tervisekontrolli näitajana automaatsel piimatootmisel: monograafia kokkuvõte [Body temperature of cows as a parameter for health control in automated milk production: abstract of monograph]. Tartu, Finland, 42 pp.
- Poikalainen, V., Ahokas, J., Praks, J., Hautala, M., Aland, A. and Veermäe, I., 2004. Automatic measurement system for cows leg disorder determination. In: Madec, F. and Clement, G. (eds.) Animal production in Europe: the way forward in a changing world. In between Congress of the ISAH: Proceedings 1. Saint-Malo, France, pp. 123-124.
- Poikalainen, V., Praks, J., Kokin, E., Aland, A., Veermäe, I., Peets, S., Ahokas, J., Pastell, M., Hautala, M., Berckmans, D., Bahr, C. and Miljkovic, D., 2010. Elaboration of basic methods for automatic analysis of cows' gait. *Agronomy Research* 8(1): 216-225.
- Poikalainen, V., Praks, J., Veermäe, I., Aland, A. and Vallas, M., 2011. Automatic lameness detection of dairy cows at the feed station by leg weight distribution. In: Köfer, J. and Schobesberger, H. (eds.) Animal hygiene and sustainable livestock production. Proceedings of the XV ISAH Congress 2011, Vienna, Austria, pp. 317-319.
- Polikarpus, A., Kaart, T., Kokin, E., Veermäe, I. and Poikalainen, V., 2011. Automatic monitoring of milking order in a large loose housing cowshed. In: Köfer, J. and Schobesberger, H. (eds.) Animal hygiene and sustainable livestock production. Proceedings of the XV ISAH Congress 2011, Vienna, Austria, pp. 329-332.
- Poursaberi, A., Pluk, A., Bahr, C., Martens, W., Veermäe, I., Kokin, E., Praks, J., Poikalainen, V., Pastell, M., Ahokas, J., Van Nuffel, A., Vangeyte, J., Sonck, B. and Berckmans, D., 2009. Image based separation of dairy cows for automatic lameness detection with a real time vision system. ASABE Annual International Meeting 2009, Reno, Nevada, American Society of Agricultural and Biological Engineers (ASABE), ASABE paper no 096654.
- Poursaberi, A., Bahr, C., Pluk, A., Van Nuffel, A. and Berckmans, D., 2010. Real-time automatic lameness detection based on back posture extraction in dairy cattle: Shape analysis of cow with image processing techniques. *Computers and Electronics in Agriculture* 74: 110-119.



- Praks J., Veermäe, I., Kokin, E., Poikalainen, V. and Nõmmeots, A., 2011. Monitoring animal health, environment, behaviour and welfare. In: Smith, I.G. (ed.) *Acceptable and practical precision livestock farming*. Halifax, UK, pp. 43-83.
- Rajkondawar, P., Tasch, U., Lefcourt, A., Erez, B., Dyer, R. and Varner, M., 2001. A System for identifying lameness in dairy cattle. *Applied Engineering in Agriculture*. ASAE, 18(1): 97-96.
- Rajkondawar, P., Liu, M., Dyer, R., Neerchal, N., Tasch, U., Lefcourt, A., Erez, B. and Varner M., 2006. Comparison of models to identify lame cows based on gait and lesion scores, and limb movement variables. *Journal of Dairy Science* 89: 4267-4275.
- Song, X., Leroy, T., Vranken, E., Maertens, W., Sonck, B. and Berckmans, D., 2008. Automatic detection of lameness in dairy cattle – Vision-based track way analysis in cow's locomotion. *Computers and Electronics in Agriculture* 64: 39-44.
- Teye, F.K., Hautala, M., Pastell, M., Praks, J., Veermäe, I., Poikalainen, V., Pajumägi, A., Kivinen, T. and Ahokas, J., 2008. Microclimate and ventilation in Estonian and Finnish dairy buildings. *Energy and Buildings* 40: 1194-1201.
- Velmurugan, S., Chaudhury, S. and Kar, S., 2010. Automated BCS scoring system using template matching by Bayesian sequential hypothesis. The first North American conference on precision dairy management 2010. Toronto, Canada. Available at: <http://www.precisiondairy2010.com/proceedings/s11velmurugan.pdf>.
- Warren, S., Martinez, A., Sobering, T. and Andresen, D., 2008. Electrocardiographic pill for cattle heart rate determination. 30<sup>th</sup> Annual International IEEE EMBS Conference, Vancouver, BC, Canada, pp. 4852-4855.
- Wathes, C., Kristensen, H., Aerts, J. and Berckmans, D., 2008. Is precision livestock farming an engineer's daydream or nightmare, an animal's friend or foe, and a farmer's panacea or pitfall? *Computers and Electronics in Agriculture* 64: 2-10.
- Webster, J., Main, D. and Whay, H., 2004. Welfare assessment: indices from clinical observation. *Animal Welfare* 13: 93-98.

## 21. The sound makes the difference: the utility of real time sound analysis for health monitoring in pigs

S. Ferrari<sup>1</sup>, M. Silva<sup>2</sup>, V. Exadaktylos<sup>2</sup>, D. Berckmans<sup>2</sup> and M. Guarino<sup>1</sup>

<sup>1</sup>Department of Veterinary Sciences and Technologies for Food Safety, Faculty of Veterinary Medicine, Università Degli Studi di Milano, Via Celoria 10, 20133 Milan, Italy; <sup>2</sup>Measure, Model and Manage Bioresponse (M3-BIORES), Department of Biosystems, Katholieke Universiteit Leuven, Kasteelpark Arenberg 30, 3001 Heverlee, Belgium; [sara.ferrari@unimi.it](mailto:sara.ferrari@unimi.it)

### Abstract

Respiratory diseases are causes of mortality and loss of productivity in intensive pig farming. Cough is one of the symptoms and a key element for screening and diagnosis. This research shows a summary on how sound analysis may be used for intensive piggeries health monitoring: comparing the acoustic features of different type of cough sounds, analysing their acoustic features and how they may be used in an algorithm-based alarm system to automatically identify cough sounds and provide farmers an early warning about the health status of their herds. The features investigated were peak frequency, duration of sound, energy envelope and time constant. This work considers at the end an automated online recognition and localization procedure for sick pig cough sounds where the instantaneous energy of the signal is used to detect and extract individual sounds and their duration is used as a pre-classifier. Auto regression analysis is then employed to calculate an estimate of the sound signal and the parameters of the estimated signal are subsequently evaluated to identify the sounds. A localization technique based on the time difference of arrival is evaluated on *in field* data and is shown that it is of acceptable accuracy for this particular application. Finally, it is suggested that the presented application can be used to online monitor the welfare in a pig house, and provide early diagnosis of a cough hazard and faster treatment of sick animals.

**Keywords:** algorithm, cough, identification, localization, prevention

### 21.1 Introduction

Respiratory pathologies have a high prevalence in intensive pig farming and cough is their principal symptom. It is well-known that, under intensive breeding conditions, it is very unlikely for a pig to reach the slaughter weight without having encountered any kind of respiratory infection. They are also related to high mortality and a drop in production due to reduced feed conversion and growth rate. To overcome this, farmers treat diseases by administrating large spectrum antibiotics to all the animals, which, in long term, results in antibiotic resistance in both animals and meat consumers. This follow-up and treatment of diseases relate to expensive veterinarian intervention costs that are an economic face of the problem particularly relevant for farmers. Nevertheless in today's intensive livestock farming the high density of bred animals helps a rapid spread of the disease that cannot be followed by punctual observation of animals. It is common practice by veterinarians to assess cough sounds, by audio monitoring, in pig houses for diagnostic purposes. A limitation to this technique stands in the short observational period in

both time and space. To achieve this goal, there have been attempts to identify the characteristics of coughing in animals (Ferrari *et al.*, 2008; Van Hirtum and Berckmans, 2002) and automatically identify and localize cough sounds in field recordings (Aerts *et al.*, 2005; Exadaktylos *et al.*, 2009; Silva *et al.*, 2008). In this chapter it is shown an overview on the highlights of this research in the field of sound analysis for health monitoring in piggeries where cough sounds analysis has been tested as a way to diagnose respiratory pathologies by the study of their acoustic features, sound source localization and sound modelling.

## 21.2 Research and achieved results

These studies have been performed by collecting sounds data in intensive pig farms particularly affected by respiratory disease problems in different seasons and different environment to study the whole problem as much as in details. Recordings were run for several hours in order to gather a substantial number of cough sounds from each farm. Manual labelling and sound analysis were performed over the sound classes: the analysis of amplitude, peak frequency and length of sounds do not require expensive instruments or strong computational effort and anyway give very good results in differentiating sounds classes. In the beginning the research has focused on the possibility to associate specific sounds to specific respiratory diseases: the basic assumption was that sounds are easily distinguishable by human ear because of their acoustic properties and because of their sound source. Considering that diseases may involve several respiratory tree areas (larynx, bronchi, pleura, lung), those regions once affected may vary in morphology, functionality, collapsibility and elasticity (Godfrey, 1990) and the sound of a cough originating from a deep lung area will be logically different than the one produced by an irritation of the upper larynx for example. For this reason we investigate acoustic properties of three types of cough sounds originating from three different respiratory areas: cough from larynx chemical irritation, cough from bacterial pleuropneumonia infection and cough from bacterial deep lung infection producing exudates. In the past sound spectral analysis of normal breathing sounds, crackles and wheezing sounds has been already performed on humans (Gavriely *et al.*, 1984; Piirila and Sovijärvi, 1989). The spectra of the voluntary cough sound of patients with asthma, chronic bronchitis and bronchial carcinoma showed higher frequencies than cough sounds from healthy volunteers (Debrezeni *et al.*, 1990). Secretions in the airways influenced the character of cough sounds (Korpáš *et al.*, 1993) while subjects with diseases mucus or chronic bronchial obstruction showed multiple flow spikes and long cough sequences (Piirila and Sovijärvi, 1995). Later studies in our research focused on the acoustic characterization of pig coughs according to the type of infection (abiotic, abiotic coughs), experiments were conducted both in laboratory and field conditions and more than 500 GB of coughs sounds have been labelled and analysed in terms of Peak frequency, RMS and duration in order to understand which acoustic parameter was more significant as a discriminant. The results showed significant differences between the two infectious cough and the non-infectious one as shown in Figure 21.1 and 21.2.

The interest behind this discrimination, by acoustic means, stands in what are the consequences, at farm level, of coughs originating from environmental pollutants rather than coughs from infectious micro-organisms. The use and cost of antibiotics is large in these conditions and there are no, up to now, instruments that can diagnose if animals are coughing due to a spreading infection or because of poor air quality in animal husbandries. This second condition is recurrent

## 21. The sound makes the difference

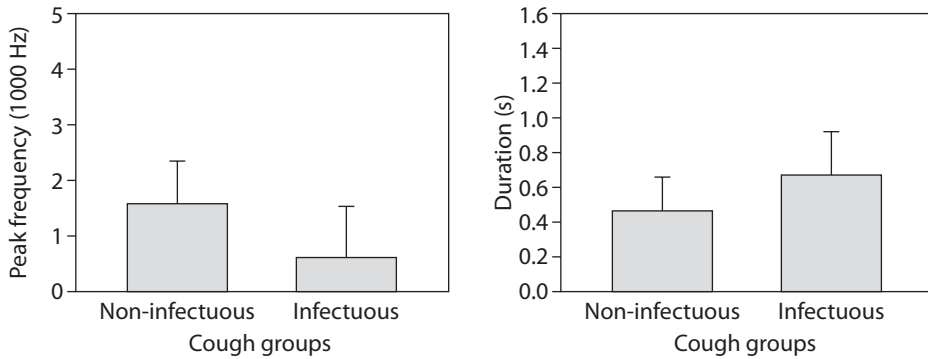

Figure 21.1. Bar plot showing the differences between peak frequency (left) and duration (right) of infectious and non-infectious coughs. (Frequency: 500 Hz for infectious and 1,574 Hz for non-infectious,  $P < 0.001$ ; duration: 0.67 s for infectious coughs and 0.43 s for non-infectious,  $P < 0.001$ ).

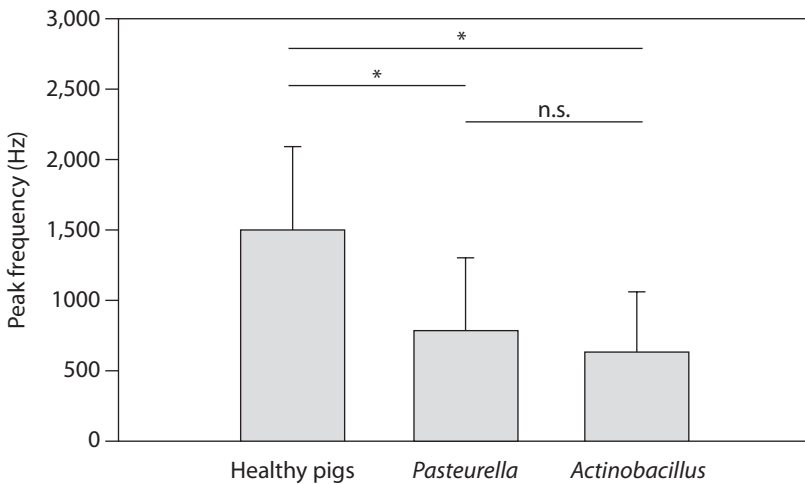

Figure 21.2. Overview of bar plot of peak frequency of the three types of cough. The representation shows the values obtained from the frequency analysis; vertical lines indicate the standard deviations for each type. Non-infectious coughs show higher peak frequency compared to coughs originating from infected animals, where we obtained lower means. The upper bars indicate the significance among the groups.

in mechanically ventilated piggeries but does not require medical treatment since changing in air quality may itself recover the health status of animals (Urbain *et al.*, 1996a,b). Also, the study of cough acoustics features became useful to train automatic classification algorithms for the early warning system: the different cough attacks collected had a typical spectrogram with smooth distributed energy over a broad frequency range. A big difference with other sounds or other voiced signals was that cough sounds do not show a clear fundamental frequency with

corresponding harmonics. Coughs could clearly be recognized as a sudden rise in frequency up to about 18 kHz, with elevated energy up to 8 kHz (Figure 21.3), followed by a decrease in frequency over time.

Besides, amplitude of sounds in terms of energy envelope (amplitude/instantaneous energy) was also important to discriminate sounds from a complete audio file. There occur great number and type of sounds that may exceed the level of background noise in farms' compartments. Coughs are in between these sounds since they contain lot of energy and they result in a sudden increase of the sound spectrum. Since low amplitude noise is recorded most of the time when a sound occurred (any sound within the pig farm) it has been recorded as a high-energy signal. Whenever the amplitude of the envelope was higher than a selected threshold it was considered that there was a recording of a sound that needed to be identified. The mean value of the envelope over the complete recording has been used for further applications and experimentations suggested that it was adequate for extracting most of the signals that are of interest. This finding has been helpful to solve another problem related to sound analysis pre-processing: labelling procedure. Labelling is the classification of sounds according to their nature. It is a basic step in sound analysis and requires hours of manual working for the operator to listen all recorded audio playbacks, voluntary extract and name all sounds of interest. This manual procedure also is very subjective and can be considered reliable only if done by expert in animal sounds interpretation. To solve subjectivity and length of this procedure we initially used the energy envelope of sound to detect and extract individual sounds from a continuous recording and their duration has been used as a pre-classifier. To automatically calculate the envelope of the continuous recorded signal we used the Hilbert Transform of a discrete time signal (Figure 21.4). The result of this procedure is presented in Figure 21.5, where a continuous recording of a cough attack is presented and the extracted sounds are shown.

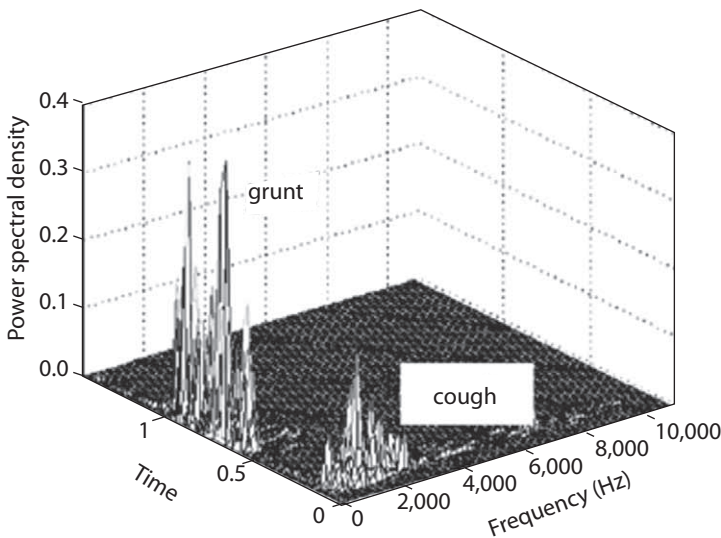

Figure 21.3. Comparison in power spectral density and frequency between pig cough sound and a grunt.

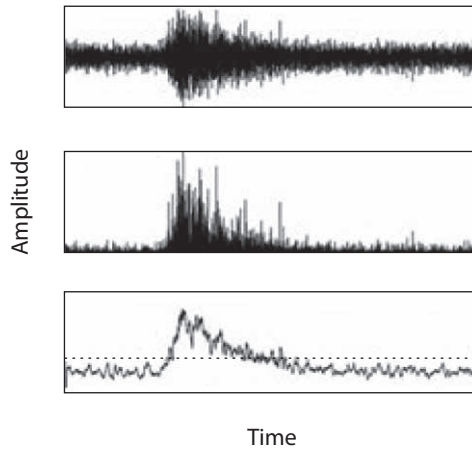

Figure 21.4. Stages of the sound extraction procedure. The cough sound (top), its energy (middle), the envelope of the energy (bottom) and the chosen threshold (horizontal line on the bottom plot).

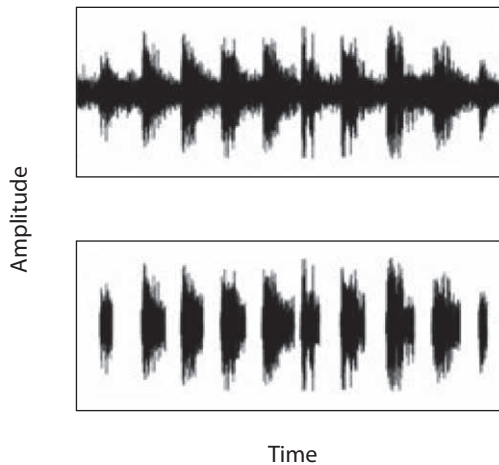

Figure 21.5. Continuous recording of a cough attack (top) and the individual sounds that are extracted by the algorithm (bottom).

This process is the base of the ‘labelling tool’: a home designed program, which automatically extract sounds from continuous audio file and helps in sound database creation (Exadaktylos *et al.*, 2009). Also, for automatic sound classification, we have been studying acoustics features by Auto Regression (AR) analysis. Cough recognition was based on both frequency and time domains and the duration of the signal. This technique evaluates fuzzy c-means clustering to parts of the training signals (pre-labelled coughs) and provides a frequency content reference

that mirrors the characteristics of sick pig cough. Sound fragments that are closer than 100 ms to each other were considered as a single sound. Furthermore, the length of each sound showed that coughs are sharp sounds that last from 200 ms up to 600 ms. Sounds that are longer than 600 ms or shorter than 200 ms are therefore considered as non-cough sounds and deleted from the process. Based on such an estimation of the actual sound signal, an attempt to form a classifier is made. It is observed that the positions of the AR parameters in a 3D space for the pre-labelled sounds can serve as an adequate and computationally efficient classifier. It is suggested that when plotting the AR parameters, those that result from sick coughs form a well-defined cluster (Figure 21.6). 88% of the sick coughs are correctly identified (12% false negatives), achieving a 92% of correct overall classification rate (with 6.8% false positive classification). This has been tested to calculate an estimate of the sound signals and their parameters to identify infectious cough sounds, non-infectious coughs sounds and other abiotic sounds.

The achieved results on sick cough sound recognition allowed a further step for real respiratory disease monitoring in farming conditions: sound source localization. There have, indeed, risen questions such as ‘How can we know that the coughs recorded belong to different animals and not only from a sick single one?’ It has been possible to get around this problem by multiple microphones recording sessions taking advantage of the time delay in reception of a sound from different microphones due to their distance from the sound sources (Figure 21.7).

In our research we used different microphones configuration using up to eight devices (Silva *et al.*, 2008). One advantage of using more sensors is the ability to extract a signal with the lowest signal to noise ratio (SNR) because signals in the microphone closer to the source will

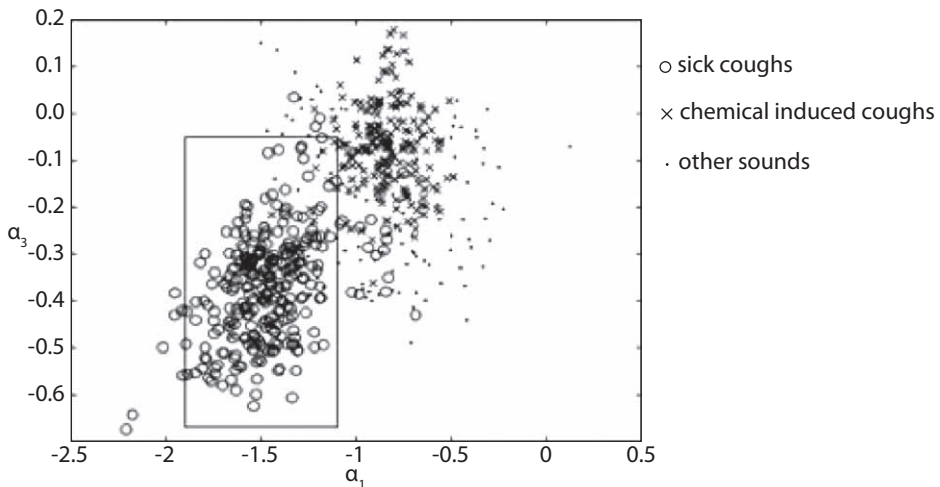

Figure 21.6. Plot of the first against the third auto regression parameter for sick coughs, chemically induced coughs and other sounds. Visual inspection suggests that the sick coughs form a cluster the centre of which (big bullet) and its boundaries are shown. The same can be observed when the other auto regression parameters are plotted against each other.

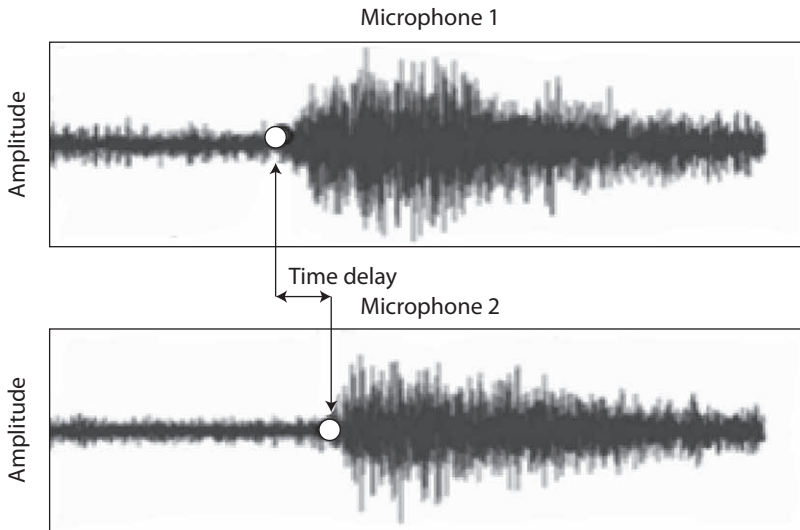

Figure 21.7. Illustration of the 'time delay' conception. The same sound is captured in two different moments from two microphones.

show highest quality. Consequently, the location of a sound source could be found by scanning the surface of the housing building and checking at which point (position) the distance of the time delay equals the distance between that point and two microphones. The cross-correlation is used by the algorithm in order to calculate the time delays between two signals captured by two channels. When multiplying the time delay with the velocity of sound (343.4 m/s at 20 °C), this results in a distance. In practice a matrix is built up for every set of two microphones, with, on every position, the difference in distance between that position and the considered microphones. From this matrix, the distance of the time delay is subtracted. The equation for this method is:

$$w_{(k,l)} = \sum_{i=1}^{n-1} \sum_{j=i+1}^n \{(d_{(k,l),i} - d_{(k,l),j}) - d_{r(i,j)}\}$$

where  $w_{(k,l)}$  represents the total weight at position  $d_{(k,l),i} - d_{(k,l),j}$ , the difference in distance between position (k,l) and microphones i and j,  $d_{(i,j)}$  the time delay between the signals at microphone i and j, and n the number of microphones.

After mapping the locations in the stable planimetry, hazard zones could be identified by markers which indicate the estimated position of the sound source (Figure 21.8).

To assess the accuracy of the method, estimated positions of a reference sound were compared with real positions in various microphone configurations. All the configurations showed good position estimation, with minimum SEM between 1.5 and 0 m, and a maximum SEM of 0.4 m. The algorithm was applied on continuous recordings from a pig house to evaluate its effectiveness. The correct localization ratio ranged from 73% (27% false positive identifications)



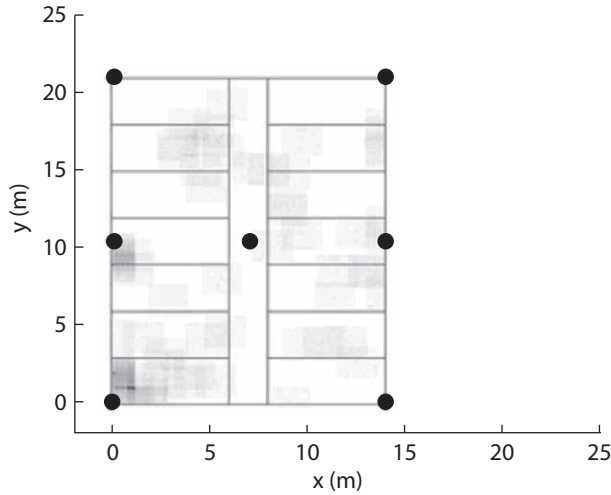

Figure 21.8. Graphical representation of the pig house and the positions of the microphones (bullet points). The cough hazard spread is shown (dark areas).

to 93% (7% false positive identifications) depending on the position of the microphone that was used for the recording. Such accurate position estimation can be used for visualizing the spread of respiratory diseases and contributes to reduce of the use of antibiotics by means of selective and early treatment of single pens instead of the whole compartment. In intensive farming condition the epidemiologic and treatment unit is considered to be the pen and not a single animal, for this reason it is important to recognize the hazard areas more than each individual animal. For the interpretation of the results, a better consideration might take into account the density of the pigs in a pen, expressing the severity of the disease as the ratio between the number of cough attacks and the number of animals per square meter (Table 21.1).

Further considerations on coughs distinction were addressed to assess if also the dynamics in the energy envelope of pig cough sounds were related to different pathological respiratory conditions. A method for modelling the energy envelope, via the time constant of the decay of energy in

Table 21.1. Effect of group size on cough attack density.

Pen no.	No. of pigs	No. of cough attacks	No. of cough attacks/no. of pigs per m <sup>2</sup>
16	19	6	4.97
15	20	3	2.36
8	23	6	4.11
6	19	1	0.83
5	23	2	1.37
4	21	1	0.75

the energy envelope, starting from its maximum, was used by using a modelling approach in which the system dynamics were described using a transfer function. Such a transfer function gave the relation between an input and an output of a dynamic system. the Young Identification Criterion (YIC) by Young, 1993 was used to select the most appropriate model order. The more the model fits the data the lower this YIC will be. Furthermore, the goodness of fit, expressed as the coefficient of determination  $R^2$  and the stability of the resulting model were calculated. In both classes of signals the simulated output approached the real output in an accurate way (lowest  $R^2 > 0.95$ ). The decay of the energy envelope also had a typical 1<sup>st</sup> order behaviour explaining the high accuracy. In both these cases, the time constant has been proven to quantify the dynamics in which biological systems respond (Figure 21.9).

Using the time constant is a relatively simple method for estimating time characteristics of cough signals giving more insight in the effect of changes in lung condition on cough sound generation. By using an artificial step input, the modelling tool will automatically fit a model through the data, describing the decay of energy in a cough sound. According to our knowledge, the researches presented in this thesis are the first application for combined online cough recognition and localization presented in the relevant literature about animal monitoring. It is clear that superior techniques for pig cough recognition from continuous recordings exist (Van Hirtum *et al.*, 2003), but are computationally more demanding compared to the one presented here. A possible way of improving the robustness of the algorithm is by considering the reverberation in the environment as suggested by Gustafsson *et al.* (2003) since the precision of the localization might be different in various pig housing constructions. The accuracy of localization, in our study, is anyway higher than the findings from other authors (Thomas *et al.*, 2002) in which SEM was between 0.8 and 1.3 m.

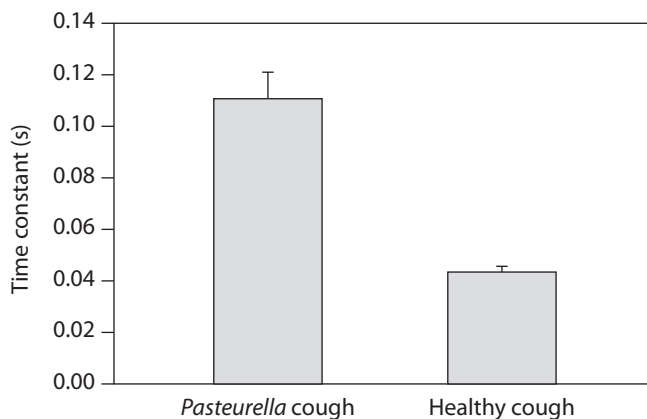

Figure 21.9. Histogram of the values of the time constants for the two classes of coughs. Time constant of infectious pig coughs has significant higher values ( $P < 0.001$ ) than healthy ones.

## 21.3 Conclusions

The results of the combination between cough sound automatic recognition and localization together with sanitary and environmental parameters show the dynamics of respiratory pathologies which allowed us to prepare an integrated diagnostic tool by means of automatic sound monitoring system. This smart system will help both farmers and veterinarians to achieve continuous feedback on the pigs' condition by automatic on-line health monitoring and hopefully contribute to the reduction of the use of antibiotics by means of selective and early treatment of single pens instead of the whole compartment.

## References

- Aerts, J.M., Jans, P. and Halloy, D., 2005. Labelling of cough data from pigs for on-line disease monitoring by sound analysis. *Transactions of the ASAE* 48(1): 351-354.
- Debrezeni, L.A., Korpáš, J. and Salát, D., 1990. Spectra of the voluntary first cough sounds. *Acta Physiologica Hungarica* 75: 117-131.
- Exadaktylos, V., Ferrari, S., Silva M., Guarino, M. and Berckmans, D., 2009. A tool for labelling individual sounds from continuous recordings: An application to bio-acoustics. *Proceedings of American Society of Agricultural and Biological Engineers*. Reno, NV, USA, reference 096486.
- Exadaktylos, V., Silva, M., Ferrari, S., Guarino, M., Aerts, J.M. and Berckmans, D., 2009. Time-series analysis for online recognition and localization of sick pig (*Sus scrofa*) cough sounds. *Journal of the Acoustical Society of America* 124(6): 3803-3809.
- Ferrari, S., Silva, M., Guarino, M., Aerts, J.M. and Berckmans, D., 2008. Cough sound analysis to identify respiratory infection in pigs. *Computers and Electronics in Agriculture* 64: 318-325.
- Gavriely, N., Palti, Y., Alroy, G. and Grotberg, J.B., 1984. Measurement and theory of wheezing breath sounds. *Journal of Applied Physiology: Respiration Environment Exercise Physiology* 57: 481-492.
- Godfrey, S., 1990. An overview: the role of respiratory-infections in the pathogenesis of airway diseases. *Seminars in Respiratory Medicine* 11: 287.
- Gustafsson, T., Rao, B.D. and Trivedi, M., 2003. Source localization in reverberant environments: modelling and statistical analysis. *IEEE Transactions on Speech and Audio Processing* 11(6): 791-803.
- Korpáš, J., Widdicombe, J.G., Vrabec, M. and Kudlička, C.J., 1993. Effect of experimental lung oedema on cough sound creation. *Respiratory Medicine* 87: 55-59.
- Piirila, P. and Sovijärvi, A., 1989. Differences in acoustic and dynamic characteristics of spontaneous cough in pulmonary diseases. *Chest* 96: 46-53.
- Piirila, P. and Sovijärvi, A., 1995. Objective assessment of cough. *European Respiratory Journal* 8: 1949-1956.
- Silva, M., Ferrari, S., Costa, A., Guarino, M., Aerts, J.M. and Berckmans, D., 2008. Cough localization for the detection of respiratory diseases in pig houses *Computers and Electronics in Agriculture* 64: 286-292.
- Thomas, R.E., Fristrup, K.M. and Tyack, P.L., 2002. Linking the sounds of dolphins to their locations and behaviour using video and multichannel acoustic recordings. *Journal of the Acoustical Society of America* 112(4): 1692-1701.
- Urbain, B., Gustin, P., Charlier, G., Coignou, F., Lambotte, J.L., Grignon, G., Foliguet, B., Vidic, B., Beerens, D., Prouvost, J.F. and Ansay, M., 1996a. A morphometric and functional study of the toxicity of atmospheric ammonia in the extra thoracic airways in pigs. *Veterinary Research Communications* 20: 381-399.

- Urbain, B., Prouvost, J.F., Beerens, D., Michel, O., Nicks, B., Ansay, M. and Gustin, P., 1996b. Chronic exposure of pigs to airborne dust and endotoxins in an environmental chamber: technical note. *Veterinary Research Communications* 27: 569-578.
- Van Hirtum, A. and Berckmans, D., 2002. Automated recognition of spontaneous versus voluntary cough. *Medical Engineering & Physics* 24(7-8): 541-545.
- Van Hirtum, A. and Berckmans, D., 2003. Considering the influence of artificial environmental noise to study cough time-frequency features. *Journal of Sound and Vibration* 266: 667-675.
- Young, P.C. and Lees, M., 1993. The active mixing volume: a new concept in modelling environmental systems. In: Barnett, V. and Turkman, K.F. (eds.) *Statistics for the Environment*. John Wiley, Chichester, UK, pp. 2-43.



## 22. The ease of movement: how automatic gait and posture analysis can contribute to early lameness detection in dairy cattle

C. Bahr<sup>1\*</sup>, A. Van Nuffel<sup>2\*</sup>, S. Van Weyenberg<sup>2</sup> and D. Berckmans<sup>1</sup>

<sup>1</sup>Division of Measure, Model & Manage Bioresponses (M3-BIORES), Katholieke Universiteit Leuven, Kasteelpark Arenberg 30, 3001 Leuven, Belgium; <sup>2</sup>Institute for Agricultural and Fisheries Research, Technology & Food Science Unit, Agricultural Engineering, 9820 Merelbeke, Belgium; [daniel.berckmans@biw.kuleuven.be](mailto:daniel.berckmans@biw.kuleuven.be)

\*Equally contributed

### Abstract

As extensive (early) lameness detection research still has not found a satisfactory solution, this book chapter reports two recent promising approaches and technical developments for early lameness detection in dairy cattle. The introduced GAITWISE system uses a pressure sensitive mat to monitor the time-dependent location of hooves touching the floor with a specific force and hence uses variables in four dimensions: two spatial, one temporal and one related to force. With this technique the asymmetry and speed seem to be the most promising variables for early lameness detection. A second technique that is described focuses on facilitating vision based information extracted from video recordings. With this system, the step overlap can be measured on the two different cow body sides which highly correlate with manual gait scoring, but there is also a large variation between individual cows in both the evolution of lameness and step overlap. The back arch of a cow during walking can be calculated by fitting a circle through selected points on the spine line. Based on this curvature value, a classification into lameness classes can be done. However, one important question remains. What is the potential of these techniques to be operated on-farm in near future?

**Keywords:** automation, lameness, welfare, pressure mat, image analysis

### 22.1 Introduction – the problem of lameness in dairy production

Lameness can be defined as an abnormal behaviour (for example reduced velocity and altered stride, curved back and lowered head) as a way to reduce the pain (Scott, 1989). In dairy cattle, metabolic stress and pain associated with lameness decreases herd productivity (Booth *et al.*, 2004), especially high producing multiparous cows tend to be at higher risk (Barkema *et al.*, 1994; Warnick *et al.*, 2001). Consequently, lameness becomes the third most important health related economic loss, after fertility and mastitis (Booth *et al.*, 2004). Economic losses can be reduced by avoiding or restricting risk factors as high energy ratios, floor type, cubicle dimensions, constant exposure to corrosive conditions (Faull *et al.*, 1996; Green *et al.* 2002; Leach *et al.*, 1997; Webster, 2002; Vermunt, 2004). Besides the search towards risk factors, early detection can be as helpful in reducing economic losses and improving animal welfare and health. Timely detection may prevent lameness from developing into a chronic condition (Clarkson *et al.*, 1996; Zimmerman, 2001).

In sound cows the body weight is applied to the four limbs and distributed over the contact area of the claws as equal as possible. Pain or discomfort disturbs this equal distribution because pain elicits protective motor and vegetative reactions, causing emotional responses and resulting in learned avoidance behaviour such as lameness. This may also modify social and other behaviour (Broom and Johnson, 1993).

As lameness and the accompanying pain and discomfort occurs in different degrees of severity, lameness might be present but not visible yet. Although necessary, early detection is therefore difficult. Frequent hoof inspections might be the best option for early detection and diagnosis of claw lesions and hence lameness, but it is not feasible under practical conditions. Hence, the development of accurate and precise early detection methodologies which can be used in practice (limited measuring time and labour and usable without intensive training and stressful animal manipulation) is a necessity.

## **22.2 Available methodologies to analyse the gait of dairy cattle**

Existing methodologies to quantify lameness rely on spotting changes in the gait and posture of cattle. They can be roughly divided into subjective methods such as visual observations leading to locomotion scorings and objective methods such as measuring physical properties of locomotion (Sedlbauer, 2005).

Visual observation and locomotion scoring methods have been used widely aiming the assessment of the quality of cow's gait and posture. Various observer scoring systems are available, most of them based on walking cows but all different in the scale used and the gait features considered. Some of these features are 'tenderness' and increased ab- and adduction (Manson and Leaver, 1988), the presence of an arched back, head bobs and short-striding (Sprecher *et al.*, 1997), and gait irregularities and 'reluctance to bear weight' (Winckler and Willen, 2001). Subjective gait scoring requires the observer to distinguish normal from abnormal walking behaviour. Despite use of a clearly defined scoring system, these observations are inherently subjective and observers must be trained thoroughly and repeatedly (Winckler and Willen, 2001). As only a trained observer may notice the onset of lameness by multiple subtle gait aberrations, detecting pre-clinical lameness tends to be difficult.

In recent research more and more attention has been paid to the development of automatic measurements of gait features. The desire to quantify information on gait features continuously in an objective way without human contact or presence led to the development of different sensor based systems to measure variables for further gait analysis. Nowadays, techniques for gait analysis such as force platforms, electromyography, accelerometers and kinematics modelling are available (Flower *et al.*, 2005). Most of these research activities focus on information gained with pressure sensitive sensors. Different walk-over measurement techniques mainly quantify gait features by spatial variables (Telezhenko and Bergsten, 2005) and/or temporal variables (Flower *et al.*, 2005; Maertens *et al.*, 2011) in kinematic gait studies. Kinetic gait studies add force related variables or focus on force (or pressure) measurements only (Pastell *et al.*, 2006; Tasch and Rajkondawar, 2004), e.g. for the calculation of the SMX scores used in the commercially available StepMetrix™ system for automatic lameness detection in cattle. Pastell *et al.* (2008) introduced a

mat made of electromechanical film, Emfit, which can detect dynamic forces. Its benefit is that it can be set up in any corridor along which the cows walk. Rushen *et al.* (2007) measured weight distribution to identify the problematic limb. Other studies rely on cow-attached sensors/markers, such as the study from Chapinal *et al.* (2011) using three-dimensional accelerometers or remote measuring techniques based on image analysis. Herlin and Drevemo (1997) used high speed cinematography to investigate the locomotion of dairy cows. The claw's ground contact sequence on the treadmill using high speed cinematography was also investigated by Meyer *et al.* (2004). Both experiments were conducted under controlled experimental conditions, and translation to commercial application would be impractical. Similar to force measurements, image processing techniques offer the possibility to quantify the gait information continuously and with more objectivity. Song *et al.* (2008) investigated the usefulness of step overlap for lameness detection by using image analysis and found good correlations between the measured step overlap and the lameness score given by human observers.

### 22.3 Two examples to approach automatic detection of lameness in moving dairy cows

Automation of animal based monitoring involves the use of information technologies, which mainly means acquisition, processing, storage and dissemination of information. Depending on the purpose of the automatic monitoring system the type of information to be acquired must be defined as well as the way to capture it. Nowadays, in livestock husbandry a wide range of sensors is available, allowing automatic recordings of defined information that can be processed and translated to variables needed to monitor key indicators of animal production such as performance or health and welfare in a reliable way.

Automatic monitoring of gait and posture and detection of lameness in dairy cattle require sensor based systems that collect and process information on the locomotion behaviour of these animals. Here, two different sensor systems, developed during the last five years, are presented as potentially useful for early detection of lameness. The first system is a walk-over system, whereas the second system is a totally non-contact system.

#### 22.3.1 Combination of spatial, temporal and force parameters for the analysis of cow gait: the GAITWISE-system

The GAITWISE system developed by Maertens *et al.* (2011) uses a pressure sensitive mat to monitor the time-dependent location of hooves touching the floor with a specific force. The cow's gait is monitored using variables in four dimensions: two spatial (X and Y), one temporal (T) and one related to force (F). Figure 22.1 visualises these dimensions during one cow's passage over the GAITWISE system. Each hoof imprint is measured about three times, which results in two complete gait cycles measured each time. Based on this raw data, 12 between-imprint variables can be calculated. In addition, each of the four imprints can also be described with its height (corresponding to stance time) and the force over time (different colours within a single imprint), which adds 8 within-imprint variables. Hence, the gait is described using 20 between and within imprint variables that are then used to calculate the more conventional gait parameters (Maertens *et al.*, 2011). However, arched back, lowering of the head, or step angle are



not based on claw-floor interactions and are consequently not directly (but possibly indirectly) measured by the pressure sensitive mat. Nevertheless, GAITWISE does provide enough data to determine the most frequently used variables in (quadruped) gait analysis literature: stride or step time and length, stance time, swing time, tracking-up, abduction, cadence and duty cycle, speed, etc. (Maertens *et al.*, 2011). In Van Nuffel *et al.* (2009), 10 specific gait parameters such as stride time, step length, asymmetry in stance time between left and right limbs, step overlap, and abduction were defined using the 20 basic variables.

GAITWISE is fully automatic and works in real time. Immediately after a cow passes the measurement zone, a list of basic and specific calculated gait parameters becomes available. The system has been extensively tested in an experimental farm, and appears to be applicable in a wide range of commercial settings. At the experimental farm, GAITWISE has a measurement success rate of over 80%. Unsuccessful measurements are most often due to occasional environmental disturbances (e.g. weather conditions, farm activities) that distract the cows. In commercial settings, this measurement success rate could be increased further by shielding the

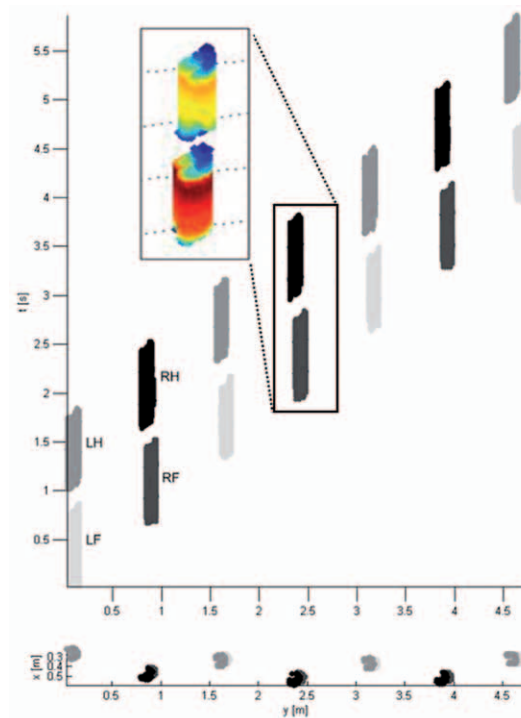

Figure 22.1. A representation of the raw data in XYT-space of one single cow walking on the GAITWISE pressure mat. Each imprint type is measured three times. In the top figure (YZ-projection) and at the bottom (XY-projection), grayscales represent the left hind (LH), left front (LF), right hind (RH) and right front (RF) imprint types. The inset shows two imprints. Blue and red colours indicate times of low and high hoof vertical ground reaction force, respectively.

sides of the measurement zone to prevent the cows from being distracted resulting in erroneous measurements when cows stop or run over the measurement zone. In research settings however, a good side view of the cows as they pass through the measuring zone is a prerequisite to allow video recordings (Figure 22.2). These videos are used afterwards to visually score the cows' gait.

Based on the specific calculated parameters, as determined from the gaitwise system, cows can be clustered to a gait score 1, 2 or 3 (varying from healthy to seriously lame). The manual scoring method used is based on the method described suggested by Winckler and Willen (2001), with an update of the scoring scale according to the Lameness Workshop in December 2007 (Ghent, Belgium) as described by Van Nuffel *et al.* (2009). This simplified observer score comprises score 1 (sound), score 2 (mild lame) and score 3 (severe lame). Compared with the observer score, the overall sensitivity and sensitivity of the gaitwise system was 76-90% and 86-100%, respectively (Maertens *et al.*, 2011). For future research on the detection of lameness, asymmetry and speed seem to be the most promising variables (Flower *et al.*, 2005; Van Nuffel *et al.*, 2009).

Up till now, only cross sectional data, measuring a large amount of cows once, were analysed. However, large variation for some of the calculated parameters between cows within the same gait score, might indicate a cow's specific way of moving. Hence early detection should rather be based on monitoring subtle deviations in the daily gait of individual cows instead of at group level. Time series analysis of other gait data has indeed been proven to be promising for lameness monitoring (Rajkondawar *et al.*, 2006). Figure 22.3 shows a time series of two asymmetry measures, 'asymmetry in stance time' and 'asymmetry in step length', as well as the variable 'slowness'. The cow in Figure 22.3 was visually seen lame by the stockpersons the 1<sup>st</sup> of December (arrow B) (this was confirmed by the gait score 3 given by the trained observer) and treated for a severe sole ulcer 20 days later (arrow C). In this specific case, both the magnitude of the slowness parameter and the variation of the asymmetry parameters change several days before (arrow A) the cow was seen lame, suggesting that time series analysis have potential to track changes in individual animal behaviour and hence, changes in health problems. On-going research focuses on these time series of kinematic gait variables to determine normal variation in the GAITWISE parameters between, as well as within cows. Moreover, abnormal variation will be compared are



Figure 22.2. Side view of a cow walking over the measurement zone for gait scoring; the pressure sensitive mat is inside the measurement bridge. An automatic gate and antenna for cow identification is located at the entrance of the measurement zone (not shown).

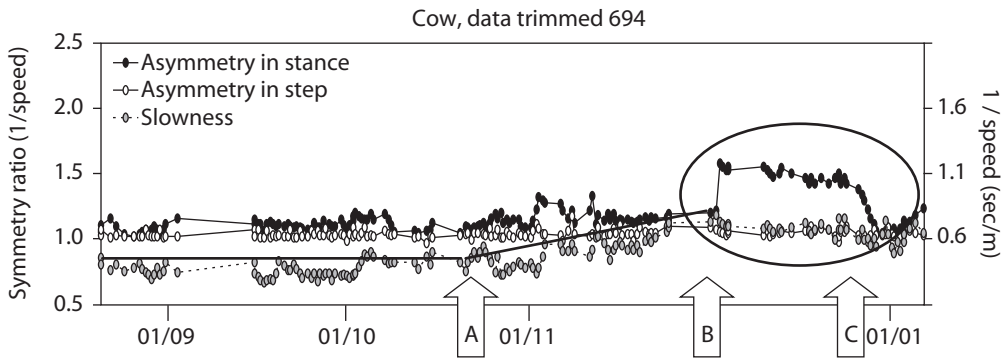

Figure 22.3. Symmetry and speed variables of one cow as a time series. Timing A suggest the start of small deviations of these 3 parameters due to upcoming lameness, timing B matches the moment the cow was seen lame by the stockpersons, on timing C, the cow was treated for a sole ulcer.

compared with veterinary records to see whether changes in gait closely correspond to the onset of lameness or proceed the visually notification of lameness.

### 22.3.2 Non-contact gait analysis with image processing techniques

Vision technology and image processing techniques offer the possibility to quantify visual information continuously, without contact and human presence. A video captured by camera (vision technology) consist of many single photographic images. Image analysis can then be described as the extraction of meaningful information from images. The use of image analysis in relation to lameness can lead to a very accurate calculation of variables describing a particular part of dairy cattle locomotion. A lot of indicators that can be used for lameness detection by image analysis are based on visual information and have been investigated in the past in order to develop manual gait scoring methods. Since the type of information used by human experts and by image analysis is the same, an intelligent algorithm might be able to automatically extract as well as assess certain gait and posture features of a cow at least as good as a human expert. Not all lameness indicators, such as tenderness seem feasible for automatic lameness detection, but all indicators that can be calculated directly or indirectly from measurable variables in an image, such as length, height, radius, angle, etc. can be of benefit.

#### Measurable gait features – step overlap and back posture

When assessing the quality of locomotion, veterinarians and ethologists consider a number of lameness indicators, including back posture, head bob, leg swing, and step overlap. Step overlap, defined as hind foot on fore foot position (Figure 22.4), has a high correlation coefficient (0.75) with locomotion score and lameness (O’Callaghan *et al.*, 2003). When a cow places her hind foot farther forward, it provides the opportunity to move her body farther and reduces the extension of the fore limbs. This can increase the efficiency of walking. Therefore, sound cows normally locate their hind feet in the same place that the front feet have just been lifted from. Zero or

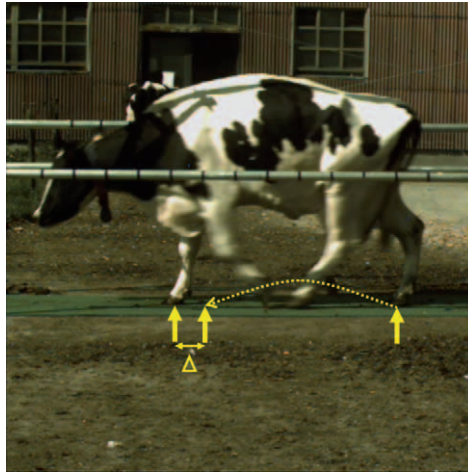

Figure 22.4. Step overlap.

positive step overlap characterizes good, progressive locomotion activity, while lameness causes negative step overlap (O'Callaghan *et al.*, 2003; Telezhenko *et al.*, 2002; Whay and Main, 1999).

Incorporating this gait feature into an image based algorithm as done by Pluk *et al.* (2010), requires several steps of which the video recording is the first one. The video recordings take place on farm. The camera is usually located at four to six meters distance away from an alley that the cows pass before arriving at the milking parlour or after leaving the milking parlour. It is placed horizontally and aimed at the centre of the passing alley. The camera records an AVI video file to the computer hard disk at a certain resolution (e.g. 1,024×768 pixels) and speed (e.g. 30 frames per second). The camera setups may differ dependent on farm design and cow traffic arrangements. After video recording and storage the following steps are processed by an algorithm programmed in MATLAB. Figure 22.5 shows a flowchart of the processing steps in image processing, imprint identification, and step overlap calculation. The results of the algorithm are compared to locomotion score given by a trained observer using the recorded video. The manual scoring method used for this research is based on the method of Van Nuffel *et al.* (2009) as described above.

This research resulted in a system that automatically measures the step overlap of the different cow body sides. Automatically measured step overlap was highly correlated with manual gait scoring ( $\rho=0.739$ ,  $P<0.001$ ;  $R^2=0.809$ ,  $P<0.001$ ). In a first experiment on 15 cows, the measured step overlap seemed to be significant for the distinction between gait scores 1 and 2. In a second experiment using a simplified scoring system on 104 cows, this distinction was only seen between gait scores 1 and 3 for the minimal step overlap and between gait scores 2 and 3 for the maximal step overlap. There was a large variation between individual cows in both the evolution of lameness and in step overlap. Technologically the automatic assessment of step overlap is possible but the gait feature 'step overlap' is subjected to a lot of variations between cows and therefore a solution must be found that certainly considers gait pattern of each individual cow. In general,

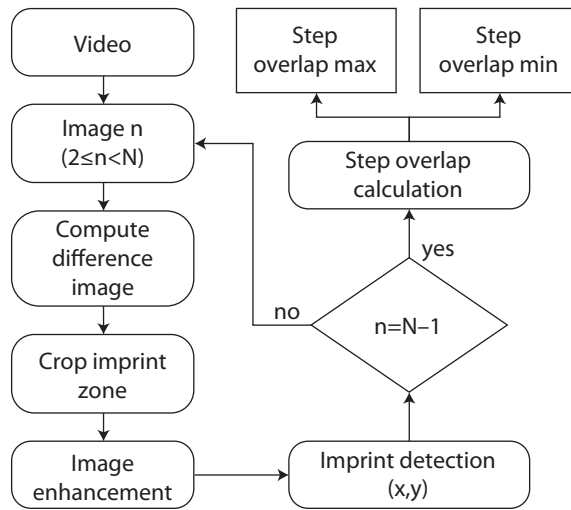

Figure 22.5. Image processing flowchart.

step overlap is a variable that shows a relationship with manual gait scores, but based on current research results it does not seem strong enough to be used as a single classifier for lameness. In combination with other gait features the success rate in classification of different lameness degrees might be improved considerable.

A second very promising variable to be investigated is the back arch. Because the back arch is quite popular in gait scoring done by experts the question was raised whether an automatic calculation and assessment of the back posture would have a benefit for lameness detection. The back arch can be defined as arch increasing as the cow moves from standing position (Bell, 2009).

Before calculating the back arch and developing an algorithm, video recording and pre-processing steps are required similar to those explained in the step overlap procedure. Afterwards, a combination of background subtraction and statistical filtering procedures are used to find the accurate shape of the cow. Then, the back arch of each cow during walking was calculated automatically by fitting a circle through selected points on the spine line (Figure 22.6). The average inverse radius of four frames displaying the hind hoofs in contact with the ground (two frames for each hind hoof) was calculated for each cow. Based on this curvature value, a score representing the status of lameness in the individual cow was given automatically (Poursaberi *et al.*, 2010).

The results of the algorithm are again compared to locomotion scores belonging to the simplified scoring scale as previously described. Experimental results from two different databases revealed promising results. In both databases good classification rates for different lameness degrees could be achieved. In the first database with 28 cows (13 sound, 10 mildly lame, 5 severely lame) only one was misclassified. In the second database with 156 (117 sound, 34 mildly lame, 5 severely lame) cows only five were misclassified. That means in total a correct classification of 96.4% and

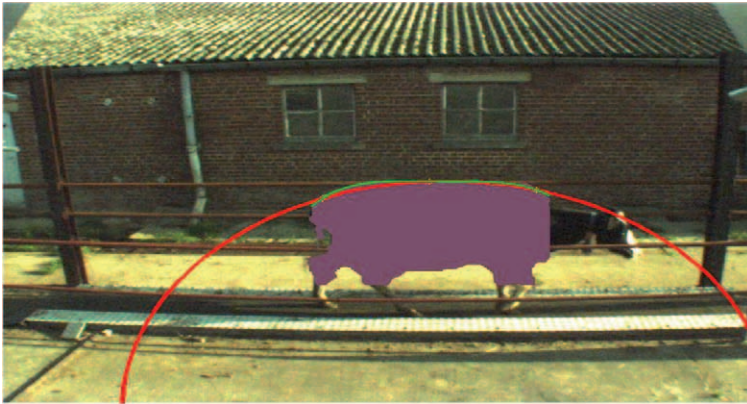

Figure 22.6. Back arch calculated by fitting a circle.

96.7%, respectively. In the first database one case was wrongly assigned to an upper class. In the second database, out of five misclassified cases, four cases were wrongly classified to an upper class (score) and one case was wrongly classified to a lower. There was no case with a two level misclassification (score 1 to score 3 or *vice versa*) and the algorithm detected all lameness cases because lame cows (score 2 and 3) were not assigned to class one (healthy cow) (Poursaberi *et al.*, 2010).

#### 22.4 The potential of automatic lameness detection systems

Although there has been lameness and early lameness detection research for more than 20 years, a worldwide commercially successful solution adopted by a majority of dairy stockpersons, still hasn't been found. There is one available product on the market for automatic lameness detection. StepMatrix™ (BouMatic) measures ground reaction forces applied to the system. To detect lameness, cows walk through the StepMatrix™ system, the forces and duration of each step are analysed and a SMX score is assigned to each hind limb of a cow. StepMatrix™ can score each cow individually even when multiple cows are moving across the system. Technically, StepMatrix™ is a mature system that is able to function reliably on farm. However, a study of Bicalho *et al.* (2007) revealed a very high specificity rate ranging from 85.4% to 94.5%, whereas the sensitivity rate appeared to be low ranging from 20.4% to 35.2%. This means, that many lameness cases are not detected. Bicalho *et al.* (2007) also concluded that visual locomotion scoring done by trained veterinarians performs better than the StepMatrix™. Although the system is indicated as being promising, a stockperson might question the cost-benefit ratio of such a system. Similar to the GAITWISE system and image analysis tools described in this chapter, there are already several technical ideas presented that might be promising in terms of automatic lameness detection. However, to the authors' knowledge none of those systems have yet become a product on the market. From a research point of view the introduced ideas have potential to serve as lameness detection systems: scientific papers provide evidence that the measured biological information can be interpreted as lameness related. Nevertheless, at this point, certain issues hamper the commercial application, namely: (1) are the results and the presentation of the results



in accordance with the expectations of stockpersons; and (2) what are the cost benefits? Moreover, an automatic system should be efficient, accurate and reliable. It should function at any time in any dairy farm and independent on climate conditions. This requires product development beyond the prove of concept with additional investments in finances, human resources and further research. Therefore, a close but complementary collaboration between universities/research institutes and companies is recommended to enhance the valorisation efforts and turn knowledge into products.

## **References**

- Barkema, H., Westrik, J., Vankeulen, K., Schukken, Y. and Brand, A., 1994. The effects of lameness on reproductive performance, milk production and culling in dutch dairy farms. *Preventive Veterinary Medicine* 20 (4): 249-259.
- Bell, N., 2009. Lameness control in dairy cattle part 2 – mobility scoring – how do you score. Available at: <http://www.nadis.org.uk/EEDA/Mobility%20Scoring%28EEDA%29.pdf>.
- Bicalho, R., Cheong, S., Cramer, G. and Guard, C., 2007. Association between a visual and an automated locomotion score in lactating cows. *Journal of Dairy Science* 90 (7): 3294-3300.
- Booth, C., Warnick, L., Grohn, Y., Maizon, D., Guard, C. and Janssen, D., 2004. Effect of lameness on culling in dairy cows. *Journal of Dairy Science* 87 (12): 4115-4122.
- Broom, D. and Johnson, K., 1993. *Stress and animal welfare*. Chapman & Hall, London, UK.
- Chapinal, N., De Pasille, A., Pastell, M., Hanninen, L., Munksgaard, L. and Rushen, J., 2011. Measurement of acceleration while walking as an automated method for gait assessment in dairy cattle. *Journal of Dairy Science* 94 (6): 2895-2901.
- Clarkson, M., Downham, D., Faull, W., Hughes, J., Manson, F., Merritt, J., Murray, R.D., Russell, W.B., Sutherst, J.E. and Ward, W.R., 1996. Incidence and prevalence of lameness in dairy cattle. *Veterinary Record* 138 (23): 563-567.
- Faull, W., Hughes, J., Clarkson, M., Downham, D., Manson, F., Merritt, J., Murray, R.D., Russell, W.B., Sutherst, J.E. and Ward, W.R., 1996. Epidemiology of lameness in dairy cattle: The influence of cubicles and indoor and outdoor walking surfaces. *Veterinary Record* 139 (6): 130-136.
- Flower, F., Sanderson, D. and Weary, D., 2005. Hoof pathologies influence kinematic measures of dairy cow gait. *Journal of Dairy Science* 88: 3166-3173.
- Green, L., Hedges, V., Schukken, Y., Blowey, R. and Packington, A., 2002. The impact of clinical lameness on the milk yield of dairy cows. *Journal of Dairy Science* 85: 2250-2256.
- Herlin, A. and Drevemo, A., 1997. Investigation of locomotion of dairy cows by use of high-speed cinematography. *Equine Veterinary Journal* 29: 106-109.
- Leach, K., Logue, D., Kempson, S., Offer, J., Ternent, H. and Randall, J., 1997. Claw lesions in dairy cattle: Development of sole and white line haemorrhages during the first lactation. *Veterinary Journal* 154 (3): 215-225.
- Maertens, W., Vangeyte, J., Baert, J., Jantuan, A., Mertens, K., De Campeneere, S., Pluk, A., Opsomer, G., Van Weyenberg, S. and Van Nuffel, A., 2011. Development of a real time cow gait tracking and analysing tool to assess lameness using pressure sensitive walkway: the GAITWISE system. *Biosystems Engineering* 110 (1): 29-39.
- Manson, F. and Leaver, J., 1988. The influence of concentrate amount on locomotion and clinical lameness in dairy cattle. *Animal Production* 47: 185-190.

- Meyer, S., Nuss, K. and Weishaupt, M., 2004. Cattle locomotion pattern – a high speed cinematographic study on the treadmill. Proceedings of 13<sup>th</sup> International Symposium and 5<sup>th</sup> Conference on Lameness in Ruminants. Maribor, Slovenia.
- O'Callaghan, K., Cripps, P., Downham, D. and Murray, R., 2003. Subjective and objective assessment of pain and discomfort due to lameness in dairy cattle. *Animal Welfare* 12 (4): 605-610.
- Pastell, M., Aisla, A., Hautala, M., Poikalainen, V., Praks, J., Veermäe, I. and Ahokas, J., 2006. Contactless measurements of cow behaviour in a milking robot. *Behaviour Research Methods* 38 (3): 479-486.
- Pastell, M., Kujala, M., Aisla, A., Hautala, M., Poikalainen, V., Praks, J., Veermäe, I. and Ahokas, J., 2008. Detecting cows lameness using force sensors. *Computer and Electronics in Agriculture* 64: 34-38.
- Pluk, A., Bahr, C., Leroy, T., Poursaberi, A., Song, X., Vranken, E., Maertens, W., Van Nuffel, A. and Berckmans, D., 2010. Evaluation of step overlap as an automatic measure in dairy cow locomotion. *Transactions of the ASABE* 53 (4): 1305-1312.
- Poursaberi, A., Bahr, C., Pluk, A., Van Nuffel, A. and Berckmans, D., 2010. Real-time automatic lameness detection based on back posture extraction in dairy cattle: Shape analysis of cow with image processing techniques. *Computers and Electronics in Agriculture* 74 (1): 110-119.
- Rushen, J., Pombourcq, E. and de Passille, A., 2007. Validation of two measures of lameness in dairy cows. *Applied Animal Behaviour Science* 106: 173-177.
- Rajkondawar, P.G., Liu, M., Dyer, R.M., Neerchal, N.K., Tasch, U., Lefcourt, A.M., Erez, B. and Varner, M.A., 2006. Comparison of models to identify lame cows based on gait and lesion scores, and limb movement variables. *Journal of Dairy Science* 89: 4267-4275.
- Scott, G., 1989. Changes in limb loading with lameness for a number of Frisian cattle. *British Veterinary Journal* 145: 28-38.
- Sedlbauer, M., 2005. Lameness and pain in dairy cows. Master thesis. University of Ljubljana, Ljubljana, Slovenia. Available at: [http://www.landfood.ubc.ca/animalwelfare/publications/pdfs/theses/2005\\_Mitja\\_thesis.pdf](http://www.landfood.ubc.ca/animalwelfare/publications/pdfs/theses/2005_Mitja_thesis.pdf).
- Song, X., Leroy, T., Vranken, E., Maertens, W., Sonck, B. and Berckmans, D., 2008. Automatic lameness detection in dairy cattle – vision-based trackway analysis in cow's locomotion. *Computers and Electronics in Agriculture* 64 (1): 39-44.
- Sprecher, D., Hostetler, D. and Kaneene, J., 1997. A lameness scoring system that uses posture and gait to predict dairy cattle reproductive performance. *Theriogenology* 47 (6): 1179-1187.
- Tasch, U. and Rajkondawar, P., 2004. The development of a SoftSeparator™ for a lameness diagnostic system. *Computers and Electronics in Agriculture* 44 (3): 239-245.
- Telezhenko, E. and Bergsten, C., 2005. Influence of floor type on the locomotion of dairy cows. *Applied Animal Behaviour Science* 93: 183-197.
- Telezhenko, E., Bergsten, C. and Manske, T., 2002. Cow locomotion on slatted and solid floors assessed by track way analysis. Proceedings of the 12<sup>th</sup> International Symposium on Lameness in Ruminants, Orlando, FL, USA, p. 417-420.
- Van Nuffel, A., Sprenger, M., Tuytens, F. and Maertens, W., 2009. Cow gait scores and kinematic gait data: Can people see gait irregularities. *Animal Welfare* 18 (4): 433-439.
- Vermunt, J., 2004. Herd lameness: a review, major causal factors, and guidelines for prevention and control. Proceedings of 13<sup>th</sup> International Symposium and 5<sup>th</sup> Conference on Lameness in Ruminants. Maribor, Slovenia, pp. 3-18.
- Warnick, L., Janssen, D., Guard, C. and Grohn, Y., 2001. The effect of lameness on milk production in dairy cows. *Journal of Dairy Science* 84: 1988-1997.



- Webster, A., 2002. Effects of housing practices on the development of foot lesions in dairy heifers in early lactation. *Veterinary Record* 151: 9-12.
- Whay, H. and Main, D., 1999. The way cattle walk: steps towards lameness management. *Cattle Practice* 7 (4): 357-364.
- Winckler, C. and Willen, S., 2001. The reliability and repeatability of a lameness scoring system for use as an indicator of welfare in dairy cattle. *Acta Agriculturae Scandinavica A* 51: 103-107.
- Zimmermann, A., 2001. Lameness in dairy cattle: are activity levels, hoof lesions and lameness correlated. The University of British Columbia, Faculty of Land and Food Systems, Vancouver, Canada, 32 pp.

## 23. Lighting for laying hens: the effect of environmental factors on bird behaviour

S. Gunnarsson

Department of Animal Environment and Health, Swedish University of Agricultural Sciences (SLU), P.O. Box 23, 53223 Skara, Sweden; [stefan.gunnarsson@slu.se](mailto:stefan.gunnarsson@slu.se)

### Abstract

The light rhythm, as well as the quality of the light source is important for the early development of the layer chicken. Lighting may influence the incidence of behavioural problems, e.g. cannibalism, and these problems decrease with appropriate rearing. Furthermore, the early exposure to perches and light type may influence the feeding and perching behaviour as well as later preference for light type. The aims of the studies were to investigate the individual differences in perching, and if environmental enrichment enhances perching at an early age, which is protecting against behavioural problems. The effect of natural and artificial light, respectively, on perching and feeding behaviour of laying hens was studied, as well as the light type preference of the birds at 14 weeks. In a separate on-farm study the lighting environments in common types of Swedish henhouses were investigated, and the HATO® light equipment was tested according to the legal requirements regarding bird health and welfare. It was found that the early perching of the chicks were positively associated with time spent under the perches, but negatively associated with social interaction. No significant effect of enrichment was found on the latency to start perching, although birds given access to enrichment on the floor had a tendency to roost earlier. It was found that chicks may change their feeding behaviour depending on day length, and access to daylight had a tendency to promote perching early in life. The start of night-time roosting was related to early day-time perch use. Birds reared in incandescent light showed a preference for incandescent light, in contrast to birds reared in natural light. In farms with various lighting systems, no severe problems of bird health or behaviour were found, except feather pecking.

**Keywords:** behaviour, perching, feeding, rearing, early development

### 23.1 Introduction

The domestic laying hen is, as its ancestor the red jungle fowl, a day-active gregarious bird. The red jungle fowl evolved in the equatorial jungle, which has a diurnal rhythm of 12 h of light and 12 h of darkness (Collias and Collias, 1967; 1996). Therefore, the lighting environment in egg production is crucial for laying hens and their egg laying.

The characteristics of the light differ depending on the source, with respect to both intensity (illuminance) and wavelength (spectrum; colour) of the light. Natural light has an even distribution of the wavelengths between 400 and 700 nm, but the content of the ultra violet A light (UVA, wavelength of 320 to 400 nm) is attenuating in natural light as the wavelength is shortening (Prescott and Wathes, 1999). The incandescent light, e.g. from ordinary light bulbs, contains more red and less blue wavelengths than natural light.

The bird eye has, in addition to the three types of cones which together register electromagnetic radiation between 400-730 nm, a fourth type of cone which allows perception of electromagnetic radiation below 400 nm. This enables the bird to perceive UVA-light (Hart *et al.*, 1999; Prescott and Wathes, 1999). Due to this, birds also have a greater spectral sensitivity than humans between 400 and 480 nm and 580-700 nm respectively, it is very likely that they will perceive light from certain light sources brighter than humans. The degree of brightness will however depend on the type of light source. Since the unit for illuminance (lux) is based upon the sensitivity of the human eye, it may not be suitable to use when describing and adjusting the light intensity in poultry houses. Instead it has been suggested that an alternative unit termed Gallilux should be used (Lewis and Morris, 1999).

Light rhythm, as well as the quality of the light source are important for the early development of chickens (Manser, 1996; Prescott *et al.*, 2003). In the wild, jungle fowl and feral hens usually roost on tree branches between dusk and dawn (Collias and Collias, 1996). However, in commercial practice hens do not always perform night-roosting, even if they have access to perches. One reason might be suboptimal light conditions, such as limited length of the light period. In organic egg production, hens shall be kept in natural light. However, there is little knowledge about the effect of different light sources on behavioural development of chicks. Early exposure to natural or artificial light might have an effect on the later preference for light type and on the behaviour of the pullets after being transferred to layer farms.

The European Union Directive on welfare of laying hens requires phasing out the battery cages by 2012 and replacement by non-cage systems and enriched cages. The ban of battery cages was motivated by the poor welfare for the hens by caused by the barrenness of the environment (Appleby, 2003). However, the non-cage systems may increase the risk of feather pecking and cannibalism (Appleby, 2003; Appleby *et al.*, 1992). Early rearing conditions influence the development of feather pecking and cloacal cannibalism (Gunnarsson *et al.*, 1999; Huber-Eicher and Audigé, 1999; Johnsen *et al.*, 1998). It has previously been found that early perch use facilitates the later use of 3-dimensional space and thus reduces floor laying and cloacal cannibalism (Gunnarsson *et al.*, 1999, 2000).

In Sweden all farm animals should have daylight inlets according to the Swedish animal welfare legislation. Therefore, all poultry houses, in conventional as well as in organic production, should have windows for natural light (SFS, 1988: 534,539). This means that buildings without proper windows or no windows at all, are required to have windows. However, inappropriate lighting management may increase the risk for behavioural problems, e.g. cannibalism and feather pecking. Thus, farmers are concerned about how to rebuild old henhouses to satisfy the legal requirements, and there are few guidelines in how to arrange these daylight inlets. Particularly in layer houses with furnished cages it may be difficult to arrange a suitable daylight inlet.

Incandescent light has until recently been the most common type of artificial light in commercial henhouses in Sweden, although it can be questioned if incandescent light is an optimal light source for to hens. It has been shown that hens prefer fluorescent tubes over incandescent light from light bulbs, mostly because of its blue wavelength (Widowski *et al.*, 1992) that physical

activities of hens might be greater in fluorescent light than in incandescent (Boshouwers and Nicaise, 1993).

There are several differences between natural and incandescent light which might have effects on the behaviour of the chicks. Natural light has a higher level of light (light intensity), it has a complete spectrum compared to incandescent light sources and its characteristics vary more than for incandescent light (Prescott *et al.*, 2003). Taylor and co-workers (2003) found that lower light intensities restricted the movement of birds, when measuring the ability to jump from perch to perch. Hens are able to show clear preferences for light, as Brown Leghorn hens were willing to work for increased light intensity and they also perceive the opportunity to control their light environment as rewarding (Taylor *et al.*, 2001).

Since the EU ban of opaque incandescent light bulbs in 2009 there is a need for replacement lighting in poultry houses in Sweden. A new lighting equipment (HATO® Agricultural Lighting) has been introduced in Sweden, that is reported to be more similar to natural light with a more even wavelength distribution between 400 and 700 nm, and it contains more of the ultraviolet A light (UVA).

According to Swedish animal welfare legislation, all new technical equipment should be approved before taken into use (SFS, 1988: 539). Scientific investigations of animal health and welfare of the housing system have to be carried out in order to give a base for making a decision on approval of the equipment. The HATO® was considered by the Swedish Agricultural Board to be a new technique in farm building and, therefore, it needed to be tested and evaluated regarding the impact on bird health and welfare, before unrestricted marketing in Sweden.

The aim of the studies was to investigate individual differences in start of perching, and if environmental enrichment enhances the latency to perch. Furthermore, the effects of different light rhythms and sources (natural and artificial light) on perching, feeding and light preferences of birds were studied. The aim of a separate study was to record the lighting environments on-farm in common types of Swedish henhouses, and as a part of this the HATO® was tested according to the legal requirements regarding bird health and welfare.

### 23.2 Animals, material and methods

In experiment 1, 90 Lohmann white day-old chicks were randomly assigned into groups of 5 individuals. All 18 pens were littered and had two wooden perches. The study included three kinds of treatments with six groups in each treatment: (C) control, (F) floor enrichment and (H) hanging enrichment. The control pens had no extra enrichment, while F pens included four wooden blocks (40×10×5 cm) and H pens had two CDs and two plastic 500 ml bottles hanging from the roof and adjusted to the eyelevel of the chicks. Behaviour of individual chicks was recorded by direct scan sampling day 5 and until day 40 (see Figure 23.1 and Heikkilä *et al.*, 2006 for details).

In experiment 2, 126 day-old LSL-chicks were randomly assigned into groups of 7 individuals distributed into littered 18 pens with two wooden perches. The study included three kinds of

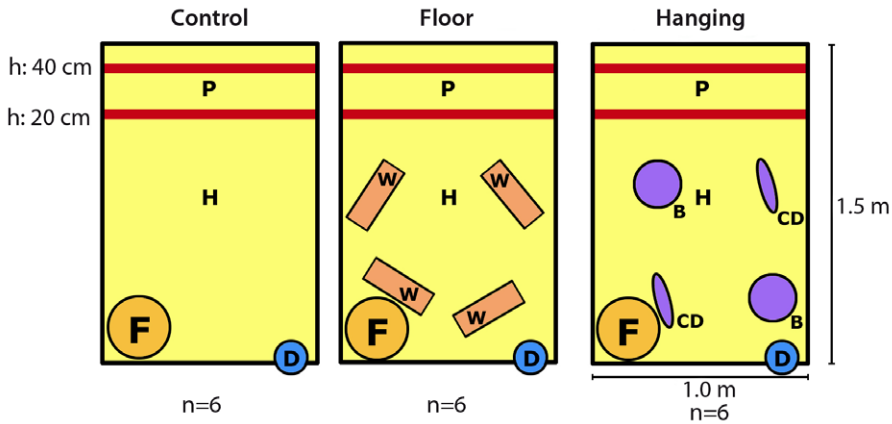

Figure 23.1. Treatment groups in experiment 1. Control had no enrichment, floor enrichment groups had four wooden blocks (W, 40×10×5 cm) on the floor and hanging enrichment groups had two CD's (CD) and two plastic bottles (B, 0.5 l) hanging from the roof. Perches (P, 20 and 40 cm), feeder (F), drinker (D) and heating lamp (H) were the same in all treatment groups (modified from Heikkilä *et al.*, 2006).

light environments: 8 h of incandescent light (A8), 16 h of incandescent light (A16) and 8 h of natural light (N8). The incandescent light was supplied by a light bulb (60 W). The natural light in N8 pens came from a window with a clear double glass. Each group of birds was video-recorded for 24 h every third day from 42 days of age to 76 days of age (see Gunnarsson *et al.*, 2008b for details). At the age of 14 weeks, the birds' light type preference was tested at group level. The test pen included one compartment illuminated by natural light, and one by incandescent light. Birds were habituated to the test pen before observations started. The number of birds in each compartment was counted using video-recording and scan sampling at 5-min intervals (see Gunnarsson *et al.*, 2008a for details).

As a pre-testing requirement of the Swedish Board of Agriculture, a limited study was performed in six commercial farms with laying hens in aviaries and modified cages, with HATO®, fluorescent or incandescent light bulbs and in one rearing farm (aviary type). Data regarding production, lighting intensity, bird health and qualitative behavioural measurements were recorded. The lighting environment was recorded regarding distribution of light in the compartments, light intensity and spectral distribution. Clinical inspections and qualitative behavioural studies were performed on a random sample of 100 birds in a rearing farm and during the egg laying period in an aviary farm and a farm with enriched cages, both with HATO®. Pullets were inspected at 1, 10 and 14 weeks of age, and the production flocks were inspected at 35, 55 and 70 weeks of age. The scoring was done modified after Gunnarsson *et al.* (1995) and Welfare Quality® (Anonymous, 2009). Qualitative behavioural records were performed according to methodology used in Welfare Quality® and based on principles developed by Wemelsfelder *et al.* (2001, 2007).

**23.2.1 Statistics**

In experiment 1 the individual behaviour data, as well as, the effect of treatment on the start of perching were analysed using ANOVA (SPSS 11.0). The effect of treatment on learning from social facilitation was analysed using the Prentice-William-Peterson (PWP) model of survival analysis (STATA 8.0).

In experiment 2, the daytime and night time feeding were modelled by one-way ANOVA using JMP Statistical Discovery Software (2003). The onset of night perching was analysed by Cox proportional hazards modelling and the preference of natural over incandescent light was modelled by linear mixed modelling using SAS PROC MIXED (SAS Institute Inc., 1997, 2003) comparing treatments with respect to the proportions of birds observed in natural light compartment before and after changing sides, calculated as group means (log-transformed) for all 5-min recordings during each test period, in total 24 observations. The model included treatment, test period (before and after reversing), and a random-intercept effect of group nested within treatment, accounting for repeated measures of groups (before and after reversing). The corresponding preferences were tested by calculating the differences between these proportions and 0.5 (no preference) on the log scale, dividing by standard error estimates and comparing to a t-distribution with 21 degrees of freedom.

**23.3 Results**

In experiment 1, the latency to perch was positively associated with time spent under the perches during the first 2 weeks of chicks' life ( $P=0.01$ ). Time spent under the heating lamp during the first 3 weeks and interacting with other chicks was negatively associated with latency to perch ( $P<0.01$ ). Perching latency was positively related to night-time roosting early in life ( $P=0.02$ ). The first perching observation was recorded during the day-time for every individual. There was no significant effect of the treatments on perching latency (overall  $P=0.21$ , ANOVA). There was no significant effect of treatment on social facilitation (overall  $P=0.15$ , PWP), although a tendency to a positive effect in enrichment on floor (C) was found (Figure 23.2).

In experiment 2, A8 and N8 birds did not differ in their feeding behaviour, whereas the mean proportion of birds feeding in A16 was significantly lower than in A8 ( $P<0.001$  during daytime and  $P<0.001$  during nighttime). N8 birds had a borderline significantly earlier onset of night perching than A8 birds (hazard ratio=8.5; Chi-square (1 df) =3.7;  $P=0.056$ ). A16 was not significantly different from A8 in latency for night perching ( $P=0.43$ ). In the preference test all birds entered the natural light compartment voluntarily at least once. A8 groups had a 2.6 times higher probability to choose natural light than N8 groups ( $P=0.04$ ) (Figure 23.3). Predicted mean proportions of birds choosing natural light in groups N8 and A8 were 0.36 and 0.13, respectively. A preference for incandescent light was seen in A8 ( $P<0.001$ ) but not in N8.

In the on-farm study, the median flock size in the production flocks was 15,840 (min 3,000; max 31,658) and median mortality during the production period (from delivery until end of lay) was 0.9% (min 0.8%; max 4.3%). The median laying rate was 93% (min 91%; max 94%) and the median feed consumption was 120 g per day and bird (min 114; max 124).

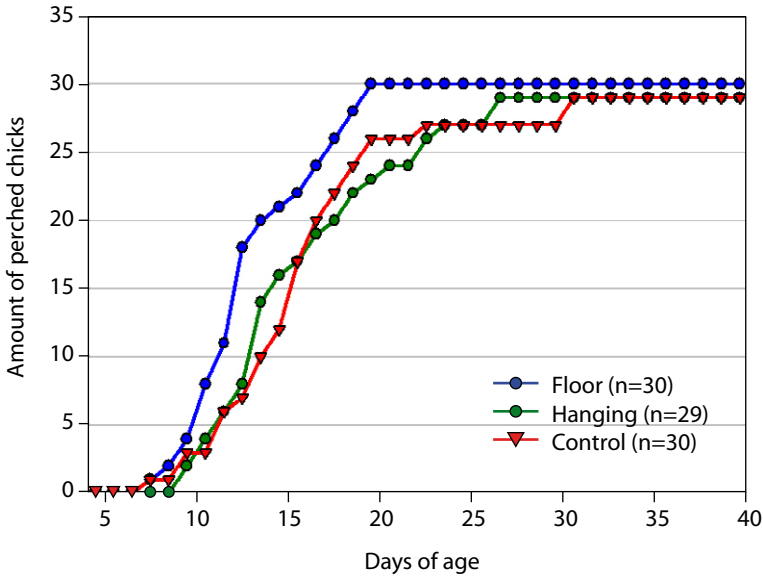

Figure 23.2. Cumulative number of chicks observed perching for the first time in experiment 1. The overall effect of treatment was not significant ( $P=0.21$ , ANOVA,  $n=18$ ). (Modified from Heikkilä et al., 2006).

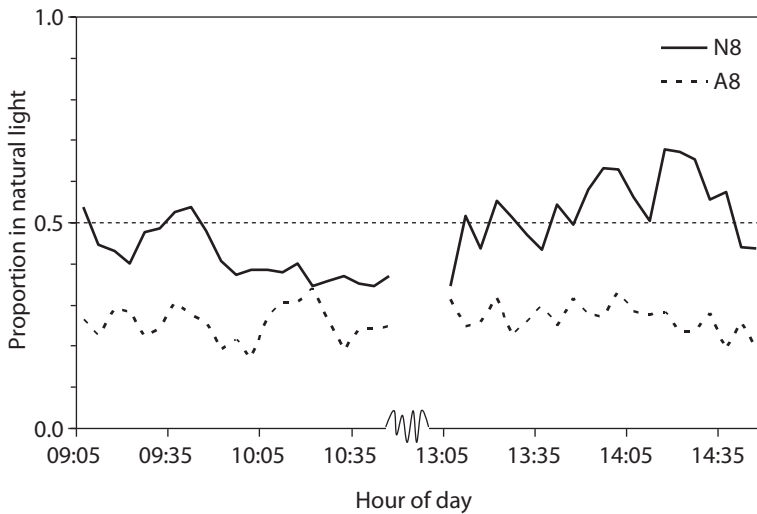

Figure 23.3. Mean proportion of birds in natural (as opposed to incandescent) light in a preference test of 12 groups of 14-week LSL chicken reared in 8 h of natural light per day (N8), or 8 h of incandescent light per day (A8), performed from 9:05 to 10:45 a.m. and from 1:05 to 2:45 p.m., 5 min recordings in one day in 2004. Natural light was presented in one test compartment in the morning and in the opposite compartment in the afternoon. (Modified from Gunnarsson et al., 2008a).

Analysis of the lighting environment showed that the light was evenly distributed in all farms, but the spectral distribution and the intensity varied between farms (median 2.2 lux; min 0.7 lux; max 26 lux). Farms with HATO® or fluorescent light were found to have higher light intensities than those with incandescent light bulbs.

All animals were scored normal during rearing at the rearing farm. In the aviary farms 26% to 64% of the birds were found to have mild keel bone deviation that increased with age. Aviary birds and birds in modified cages had deteriorating plumage with age and at end of lay almost all birds had featherless areas on neck, wings and breast (96-100%). More birds in aviary farms were featherless on the back than birds in modified cages (97% vs. 30%). Other severe clinical remarks were rare.

Qualitative behavioural observations performed by different observers at the same scoring time had an acceptable agreement. No significant difference was found for important parameters, but the scoring of birds in modified cages showed a larger variation compared to aviary birds.

### 23.4 Discussion

The rearing conditions have a great impact on later behaviour and welfare of hens (Blokhuis and Wiepkema, 1998; Huber-Eicher and Sebö, 2001; Johnsen *et al.*, 1998). Since perch use has been found to be very important for the welfare of the hens (Gunnarsson *et al.*, 1999; Huber-Eicher and Audigé, 1999), it is important to find the mechanisms influencing initiation of perching behaviour. It was found that certain behaviours are related to early perching and that night- and daytime perching latency are related. Furthermore, it was found that light rhythm affects the diurnal feeding behaviour of chicks. Chicks reared with a long night-time were observed feeding also during their dark night-time period and at a more intense schedule during the daytime. The results suggest that chicks are able to adapt their diurnal behaviour according to the lighting regime provided, although a long night-time period might force the chicks to feed in darkness. However, there was no significant difference in perching between birds reared in incandescent light, whether they had a short or long dark period. It was found that rearing chicks in natural light promotes an earlier onset of perching than when incandescent light is used. It has been suggested that exposure to natural light would be an ideal solution to many lighting problems and that it increases the welfare of domestic fowl (Prescott *et al.*, 2003). The present results support the idea that pullets for organic egg production can benefit from being reared with access to natural light. However, there is a need for investigating which aspects of natural light are crucial for the behaviour and welfare of adult hens, and how to expose the birds optimally to these factors.

Due to the limited number of observations in the on-farm study; it was not possible to perform any extended statistical analysis of the results. The lighting environment varied between the different lighting types as would be expected. No severe problems of bird health in the flocks studied were found except for feather pecking; but the pattern of feather pecking did not show a clear correlation to the housing or light system. The results will be considered by the Swedish Board of Agriculture in the process of approving the lighting equipment HATO®, in order to analyse if it can be excluded that the equipment has negative effects on bird health and welfare. Feather pecking has previously been reported to be caused by various risk factors related to e.g.



genetics, nutrition and rearing environment (Weeks and Nicol, 2006). It has also been reported that light sources with low wave lengths spectrum and high light intensities is increasing the risk of feather pecking (Mohammed *et al.*, 2010). However, in the present study it was not possible to identify single factors causing the feather pecking.

### **23.5 Conclusion**

Early start of perch use was positively associated with night-time roosting, but no significant effect of enrichment was found. Access to natural light was found to precipitate the onset of night-time perching in the life of the pullet. Furthermore, birds reared in incandescent light showed a preference for incandescent light, in contrast to birds reared in natural light.

Although lighting environment varied between the different farms in the on-farm study, no severe problems of bird health in the flocks studied were found, except for feather pecking. The pattern of feather pecking did not show a clear connection to the housing or light system.

### **References**

- Anonymous, 2009. Welfare quality® assessment protocol for poultry. ISBN/EAN 978-90-78240-06-8, Welfare Quality® consortium, Lelystad, the Netherlands, 119 pp.
- Appleby, M.C., 2003. The European Union ban on conventional cages for laying hens: history and prospects. *Applied Animal Welfare Science* 6: 103-121.
- Appleby, M.C., Hughes, B.O. and Elson, H.A., 1992. Poultry production systems: behaviour, management and welfare. Cab International, Wallingford, UK, 238 pp.
- Blokhuis, H.J. and Wiepkema, P.R., 1998. Studies of feather pecking in poultry. *Veterinary Quarterly* 20: 6-9.
- Boshouwers, F.M.G. and Nicaise, E., 1993. Artificial light sources and their influence on physical activity and energy expenditure of laying hens. *British Poultry Science* 34: 11-19.
- Collias, N.E. and Collias, E.C., 1967. A field study of the red jungle fowl in north-central India. *Condor* 69: 360-386.
- Collias, N.E. and Collias, E.C., 1996. Social organization of a red jungle fowl, *Gallus gallus*, population related to evolution theory. *Animal Behaviour* 51: 1337-1354.
- Gunnarsson, S., Odén, K., Algers, B., Svedberg, J. and Keeling, L., 1995. Poultry health and behaviour in a tiered system for loose housed layers. Report 35. Department of animal hygiene, SLU, Skara, Sweden, 112 pp.
- Gunnarsson, S., Keeling, L.J. and Svedberg, J., 1999. Effects of rearing factors on the prevalence of floor eggs, cloacal cannibalism and feather pecking in commercial flocks of loose housed laying hens. *British Poultry Science* 40: 12-18.
- Gunnarsson, S., Yngvesson, J., Keeling, L.J. and Forkman, B., 2000. Rearing with early access to perches impairs spatial skills of laying hens. *Applied Animal Behaviour Science* 67: 217-228.
- Gunnarsson, S., Heikkilä, M., Hultgren, J. and Valros, A., 2008a. A note on light preference in layer pullets reared in incandescent or natural light. *Applied Animal Behaviour Science*. 112: 395-399.
- Gunnarsson, S., Heikkilä, M. and Valros, A., 2008b. Effect of day length and natural versus incandescent light on perching and the diurnal rhythm of feeding behaviour in layer chicks. *Acta Agriculturae Scandinavica, Section A – Animal Science* 58: 93-99.

- Hart, N.S., Partridge, J.C. and Cuthill, I.C., 1999. Visual pigments, cone oil droplets, ocular media and predicted spectral sensitivity in the domestic turkey, *Meleagris gallopavo*. *Vision Research* 39: 3321-3328.
- Heikkilä, M., Wichman A., Gunnarsson S. and Valros, A., 2006. Development of perching behaviour in chicks reared in enriched environment. *Applied Animal Behaviour Science* 99: 145-156.
- Huber-Eicher, B. and Audige, L., 1999. Analysis of risk factors for the occurrence of feather pecking in laying hen growers. *British Poultry Science* 40: 599-604.
- Huber-Eicher, B. and Sebö, F., 2001. The prevalence of feather pecking and development in commercial flocks of laying hens. *Applied Animal Behaviour Science* 74: 223-231.
- Johnsen, P.F., Vestergaard, K.S. and Nørgaard-Nielsen, G., 1998. Influence of early rearing conditions on the development of feather pecking and cannibalism in domestic fowl. *Applied Animal Behaviour Science* 60: 25-41.
- Lewis, P.D. and Morris, T.R., 1999. Light intensity and performance of domestic pullets. *World's Poultry Science Journal* 55: 241-250.
- Manser, C.E., 1996. Effects of lighting on the welfare of domestic poultry: a review. *Animal Welfare* 5: 341-360.
- Mohammed, H.H., Grashorn, M.A. and Bessei, W., 2010. The effects of lighting conditions on the behaviour of laying hens. *Archiv für Geflügelkunde* 74: 197-202.
- Prescott, N.B., and Wathes, C.M., 1999. Spectral sensitivity of the domestic fowl (*Gallus g. domesticus*). *British Poultry Science* 40: 332-339.
- Prescott, N.B., Wathes, C.M. and Jarvis, J.R., 2003. Light, vision and the welfare of poultry. *Animal welfare* 12: 269-288.
- SAS Institute Inc., 1997. The PHREG procedure. In: SAS/Stat software: Changes and enhancements through release 6.12., Cary, NC, USA.
- SAS Institute Inc., 2003. The SAS system for windows, release 9.1.3 service pack 2, ts-level 01m3. SAS Institute Inc., Cary, NC, USA.
- SFS, 1988. The Swedish animal protection act. The Swedish Parliament, Stockholm, Sweden, p. 534.
- SFS, 1988. The Swedish animal protection ordinance. The Swedish Government, Stockholm, Sweden, p. 539.
- Taylor, P.E., Coerse, N.C.A. and Haskell, M., 2001. The effects of operant control over food and light on the behaviour of domestic hens. *Applied Animal Behaviour Science* 71: 319-333.
- Taylor, P.E., Scott, G.B. and Rose, P., 2003. The ability of domestic hens to jump between horizontal perches: effects of light intensity and perch colour. *Applied Animal Behaviour Science* 83: 99-108.
- Weeks C.A., and Nicol, C.J., 2006. Behavioural needs, priorities and preferences of laying hens. *World's Poultry Science Journal* 62: 296-307.
- Wemelsfelder, F., 2007. How animals communicate quality of life: the qualitative assessment of behaviour. *Animal Welfare* 16: 25-31.
- Wemelsfelder, F., Hunter, E.A., Mendl, M.T. and Lawrence, A.B., 2001. Assessing the 'whole animal': a free-choice-profiling approach. *Animal Behaviour* 62: 209-220.
- Widowski, T.M., Keeling, L.J. and Duncan, I.J.H., 1992. The preferences of hens for compact fluorescent over incandescent lighting. *Canadian Journal of Animal Science* 72: 203-211.



## 24. They have seen the light: 3D light distribution and effects of light intensity on animal welfare in swine husbandry<sup>7</sup>

A. Costa<sup>1</sup>, A. Van Brecht<sup>2</sup>, M. Porro<sup>1</sup>, D. Berckmans<sup>2</sup> and M. Guarino<sup>1</sup>

<sup>1</sup>Department of Health, Animal Science and Food Safety, Faculty of Veterinary Medicine, Università degli Studi, via Celoria 10, 20133 Milan, Italy; <sup>2</sup>M3-BIORES: Measure, Model & Manage Bioresponses, Katholieke Universiteit Leuven, Kasteelpark Arenberg 30, 3001 Leuven, Belgium; [annamaria.costa@unimi.it](mailto:annamaria.costa@unimi.it)

### Abstract

EU rules for the welfare of pigs define 40 lx for a minimum period of eight hours per day as the minimum standards of light intensity in swine buildings. The aim of this study was to verify if the 40 lx light intensity level requested by EU rules was achieved in naturally vs. artificially illuminated areas of a pig house and to investigate light intensity distribution within the building and the pens. For this purpose, light intensity was continuously monitored in two compartments of a piggery at the height of 1.50 m along the central corridor, according to standard inspections adopted in pig farms. As a second step, light intensity was measured in a three dimensional grid at 5 heights (0 to 1.5 m) in six different positions in the pens to investigate light distribution at the heights of animals and humans. The light intensity level required by EU rules was reached  $93 \pm 5.65\%$  (9:00 am to 5:00 pm) in the artificially illuminated areas. In pens illuminated only by natural light and without dunging areas, the 40 lx level was never reached, while in pens with dunging areas the 40 lx were reached  $83 \pm 1.83\%$  (9:00 am to 5:00 pm). Analysis of the 3D distribution of light intensity revealed that the light level remained very low (15 lx) inside the pen.

**Keywords:** pig house, light intensity, 3D light distribution, EU regulations, animal welfare

### 24.1 Introduction: lighting standards to meet pig welfare guidelines

Light is an important exogenous stimulus in the control of many physiological and behavioural processes of animals (Robbins *et al.*, 1984). Light intensity may influence motivation, particularly for visually mediated behaviours such as foraging and social interactions, via stimulation of different aspects of the visual system (e.g. photopic vs. scotopic vision).

The environmental control of this parameter is regulated by European rules (Commission Directive 2001/93/EC) defining minimum standards for the welfare of pigs. In addition to the relevant provisions of the Annex to Directive 98/58/EC, the following requirements apply: 'pigs must be kept in light with an intensity of at least 40 lx for a minimum period of eight hours per day'. The intention of this rule was to remedy to the practice of keeping pigs in dim light, as is widely done by farmers in order to reduce fights and competition. However, the rule does not

<sup>7</sup>The material presented in this chapter is taken from the paper: Costa, A., Van Brecht, A., Porro, M., Berckmans, D. and Guarino, M., 2009. Quantification of three dimensional light distribution in pig houses. Transactions of ASABE 52: 1677-1682.

specify protocols for measuring light intensity and does not justify the adoption of 40 lx as the standard for swine welfare.

There is wide and sometimes contradictory literature about light effects on pig behaviour and on animal performance. In general, light intensity does not seem to be a variable of great importance affecting the welfare of pigs. Van Putten (1980) was unable to prove experimentally that the behavioural repertoire of pigs, and indirectly their welfare, could be influenced by the presence or absence of light, although, according to anecdotal evidence, it is better to keep pigs in darkness to keep them calm and to avoid aggression. Nevertheless, tail biting was found to decrease greatly when, apart from other variables, pigs were maintained in a warm and low light environment (van Putten, 1968). Aggression among unfamiliar, recently grouped individuals was also greatly reduced when pigs were in darkness (Barnett *et al.*, 1994).

Frederiksen *et al.* (2006), studying the effects of artificial light programmes in entire male pigs, demonstrated that androstenone levels were lowered when pigs were reared in low light intensity, but the daily weight gain and the carcass weight increased.

Van Putten and Elshof (1983) stated that the welfare of pigs is reduced when kept at very low level environmental illumination (less than 0.2 lx). When pigs were allowed to move freely between two lightproof pens one of which was illuminated only by 0.1 lx (i.e. virtual darkness) and the other by 60 lx, there was no difference between time spent in each pen over a period of 8 days (van Rooijen, 1985). In addition, there was no evidence of illumination preference throughout the circadian rhythm. During the night, the pigs stayed in the twilight pen almost the same amount of time as in the light pen (Baldwin and Meese, 1977, Van Rooijen, 1985).

Nevertheless, as reported in the Report of the Scientific Veterinary Committee (1997), pigs seem to dislike intense light. When pigs were kept in darkness and trained to operate an infrared beam to obtain 40 seconds of light, they spent 54% of their time over the 24-hour period activating an intense light lamp (110 lx). When the light intensity was reduced to 10 lx, pigs activated the beam only 63% of time. Low light levels do not reduce fighting or wounding of pigs during weaning (Christison, 1996), although for fattening pigs, tail damage was greatest in the brightly lit pens compared to completely dark ones (Van Putten, 1984). Baldwin and Start (1985) suggest that piglets prefer to be in bright light (110 lx) rather than in dim light (10 lx), while other studies (Taylor *et al.*, 2003) show that piglets prefer darkness (<4 lx) rather than bright illumination (400 lx). McGlone and Curtis (1985) found that nursery pigs showed no benefit from any specific photoperiod. The preference of light intensity seems to be related to other variables such as management and environmental conditions.

The situation is different for breeding sows: Stevenson *et al.* (1983) demonstrated that providing supplemental light (16 h/d) in farrowing rooms for lactating sows increased the weight of litters weaned at 4 wk of age and resulted in more prompt return to oestrus after weaning.

However, to our knowledge, the 3D spatial distribution of light intensity in livestock houses has never been measured in field conditions. Like all other micro-environmental variables, even light

intensity will have spatial variations, and few studies have been reported to determine lighting distribution and intensity in pig houses.

The aim of this study was to evaluate light intensity within two different compartments for fattening pigs varying in floor type, ventilation system and lightning (artificial vs. natural light) in the same pig house. Measurements were conducted to verify if the 40 lx indicated by EU rules as the minimum standards for the welfare of pigs was reached in two different illumination systems. The 3D distribution of light intensity within the two compartments was compared in natural vs. artificial light, to document the spatial differences in light intensity at human and at pig height.

## 24.2 Materials and methods

### 24.2.1 Static measurements

The trial was performed from the end of May until the beginning of September 2005 in a piggery in Northern Italy. Animals lodged in the building were fattening pigs for Parma ham production (from 90 to 160 kg). The top view of the piggery, the barn orientation and the compartment subdivision in pens are represented in Figure 24.1.

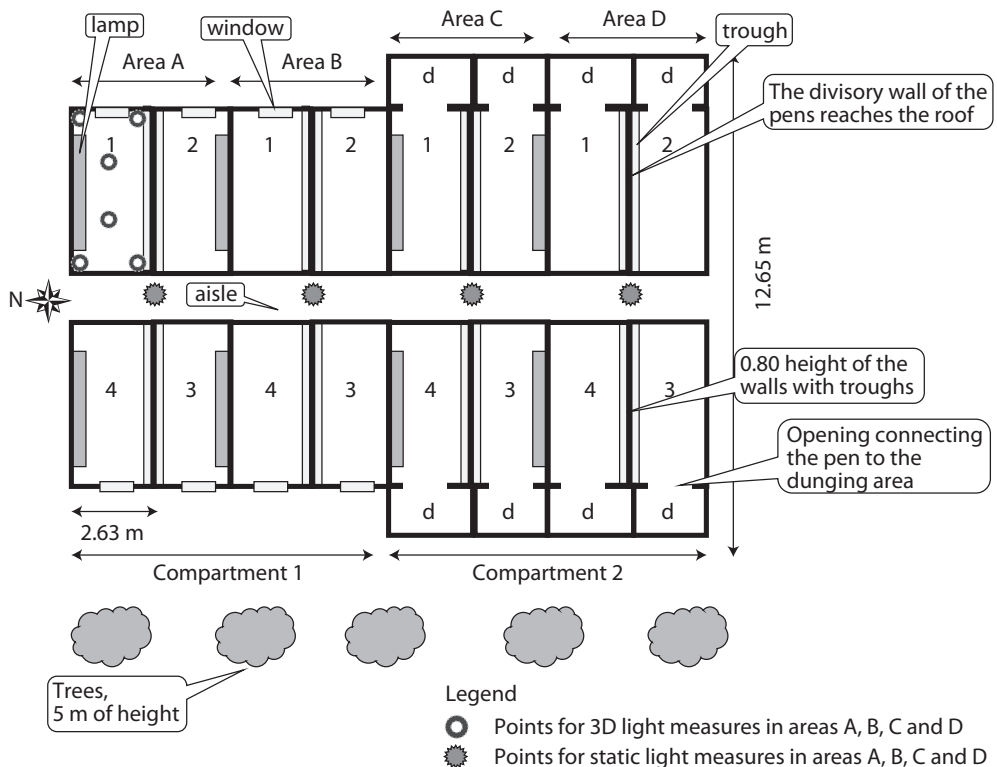

Figure 24. 1. Layout of the pig house.

The pig house containing the two compartments was a building 21 m long and 12.5 m wide. The building had concrete block walls 2.05 m high, with or without inlets depending on the room ventilation system. The roof was made of pre-cast concrete sheets and had an inclination angle of about 30°. A 1.3 m aisle, running the length of the building was used for both access and the movement of pigs to the weighing system. The barn surface made of pre-cast concrete blocks was not painted.

The floor was solid concrete with pen fronts and sides constructed of pre-cast concrete blocks approximately 1 m high. Every compartment was divided in 8 pens each 5.63 m long and 2.63 m wide. Each pen had a vertical window designed to introduce light into the building. Windows (see Figure 24.1) had a surface of 1.32 m<sup>2</sup> (0.6×2.2 m; H×W) and were located 2 m above the floor. Pens within the same area were separated by a wall made of concrete blocks of a height of 1 m. Each pen could be opened for cleaning and removal of the manure. Each pen provides the same length of trough space per animal. Compartment 1 had a concrete slatted floor, with 10 cm wide slats and 2 cm wide gaps. This compartment was mechanically ventilated with the extraction of the exhaust under the pit.

Compartment 2 with a solid concrete floor, had an external dunging area (d in Figure 24.1, 1 m wide) and natural ventilation. Fresh air entered the compartment through the dunging area doors, and exhaust air was removed through windows and a chimney placed in the middle of the roof. The openings (Figure 24.1) between dunging area and inside were 1.20 m high and 0.60 m wide.

Each compartment was subdivided in two areas. In each compartment one area (A and C) was artificially illuminated from 9:00 am to 5:00 pm, while the other ones (B and D) were illuminated only by natural light. As shown in Figure 24.1, four lamps per area (one per pen) were positioned 3 m above the floor in the pens artificially illuminated areas. The lamps (GE Lighting, Cod. RS 377-9305, GE lighting Italia SPA, Cavazzale, Italy) had a reflector 2 micron thick, high-gloss, anodized aluminium, 1.5 m long, the power was 58 W×2 lamp with a medium beam of 16°-25°.

### **24.2.2 Light intensity measurements**

#### *Static measurements*

During the four months of experimental study, light intensity was recorded continuously using light sensors (MW8501.7 LSI instruments, Settala, Milano, Italy). The luxmetric probe was placed 1.50 m above the floor along the central corridor, in the middle of each area (Figure 24.1), as the most representative location for daily light intensity. The 1.50 m height was chosen according to the conventional procedure adopted for light level inspections in pig farms. The probe was connected to a Datalogger (BABUC M, LSI Instruments, Settala, Milano, Italy) to collect data with a frequency of 1 minute.

#### *3D Measurements*

During two clear sunny days in September from 9:00 am to 5:00 pm, light intensity was also measured on a three dimensional grid at a height of 0, 20, 75, 100 and 150 cm from the floor in

six different positions within each pen. The same sensor was used to conduct static measurements (MW8501.7 LSI instruments, Settala, Milano) every corner of the pen and in two points along the longitudinal axis of the pen, as shown in Figure 24.1 (6 points for 5 heights). During the first day, light intensity was recorded in Compartment 1 (areas A and B). During the second day, measurements were performed within Compartment 2 (areas C and D). Every measurement lasted 8 minutes per height and 48 minutes per pen. Animals were moved from the pen before measurements were taken to avoid any animal effects.

The data recorded on the three dimensional grid were processed by Matlab (MathWorks, Inc., Natick, MA, USA) to visualize the three dimensional light distribution.

Assuming that the light intensity between two measured positions in the grid is linear, a linear interpolation describes light distribution in the whole pen area. In this way, the 3D distribution of light intensity in the whole pen was calculated on the measured intensity in 6 positions (Figure 24.1). The light intensity sensor was positioned in the barn as reported in Figure 24.1. The sensor had an efficiency of 0-25 Klux, an accuracy of 3%, and a response time (T90) of 0.1 s. The sensitive element was a Silicon cell, and the parameters obtained were lighting (lx) and source light intensity.

These measured values were used to calculate the 3D gradients in light intensity, or the variation of light intensity, in a single pen and in a compartment.

### 24.2.3 Statistical Analysis

Statistical analysis of the data was performed using SAS statistical software (2008) in order to evaluate mean values in time of exposure to light in the pen. The effects of the type of room and type of lighting (artificial vs. natural) on light intensity were investigated (one-way ANOVA), and, in order to identify values lower and higher than 40 lx from 9:00 am to 5:00 pm a Frequency Analysis was performed (Proc FREQ). Light distribution inside the barn was studied using the graphical 'patch' function of MATLAB.

## 24.3 Results and discussion

The recorded mean daily light intensities (taken from 9.00 am to 5.00 pm) in the four areas of the building during the full trial are shown in Figure 24.2. On average over time, the light level was 17 lx higher ( $P<0.05$ ) in the artificially illuminated areas (A and C),  $57\pm 6$  lx (mean  $\pm$  standard deviation (SD)), compared to the naturally illuminated areas (B and D),  $40\pm 5.56$  lx (mean  $\pm$  SD). In addition, the average maximum value over time was 21 lx higher ( $P<0.05$ ) in the artificial illuminated areas,  $63\pm 8$  lx (mean  $\pm$  SD), compared to the naturally illuminated areas,  $42\pm 6$  lx (mean  $\pm$  SD). Moreover, the average minimum value was still 14 lx higher in the artificial illuminated areas,  $52\pm 6.43$  lx (mean  $\pm$  SD), compared to the naturally illuminated areas,  $38\pm 7$  lx (mean  $\pm$  SD). Area B, which was illuminated only by natural light, was on average the darkest area, with an average light intensity of  $34\pm 2.44$  lx over the whole period of observation, from May to September. Naturally illuminated area D, which had a dunging area and was located more externally in the building, had an average illumination of  $45\pm 4$  lx, which was 10 lx higher



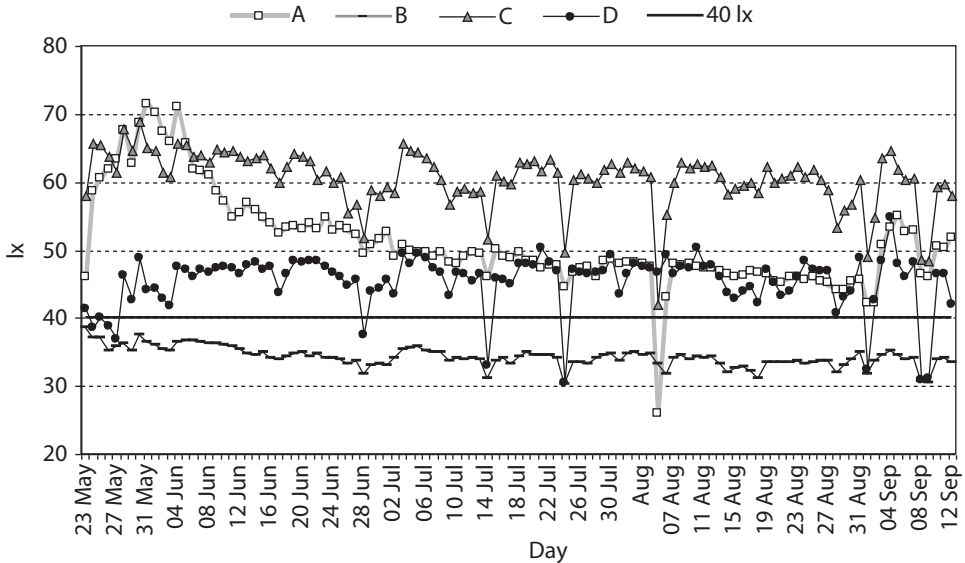

Figure 24.2. Daily mean light intensity levels from 9:00 am to 5:00 pm in the areas A, B, C and D measured at 1.5 m from the floor. The minimum light intensity value of 40 lx for keeping pigs in a piggery is shown.

than naturally illuminated area B ( $34 \pm 3$  lx). In the dunging area, the light intensity increased for the naturally illuminated area above the minimum light intensity value of 40 lx for keeping pigs as required by EU rules (2001).

The Proc Freq (SAS, 2011) performed on static measurements revealed that in the four areas, light intensity from 9:00 am to 5:00 pm was higher or equal to 40 lx for 89% of the time in area A (artificially illuminated), 0% of the time in area B, 97% of the time in area C (artificially illuminated), and 83% of the time in area D.

The analysis of three dimensional light distributions is shown in Figure 24.3, where light distribution is shown at three heights: 0 m, 0.75 m, and 1.50 m. These three heights were considered in the 3D analysis since the pig house lodged fattening pigs, so the light intensity analysis was addressed at heights with pigs lying on the floor (0 m), animal's eye level (0.75 m) and at men's eyes level (1.5 m).

Even though these heights refer to the same conditions in the same building, they show different lighting levels. At 0 m (Figure 24.3a), light intensity was almost equal to zero, probably because of the distance of the inlets from the floor. This situation could reflect positively on pigs' welfare during lying or sleeping time, since darkness has a calming effect on pigs reared in intensive livestock facilities (Van Putten, 1984).

At 0.75 m (Figure 24.3b), equivalent to pig eye level, light intensity reached the maximum value of 25 lx (indicated by the red colour) only in areas A and B (pens 1 and 2), which were located on the

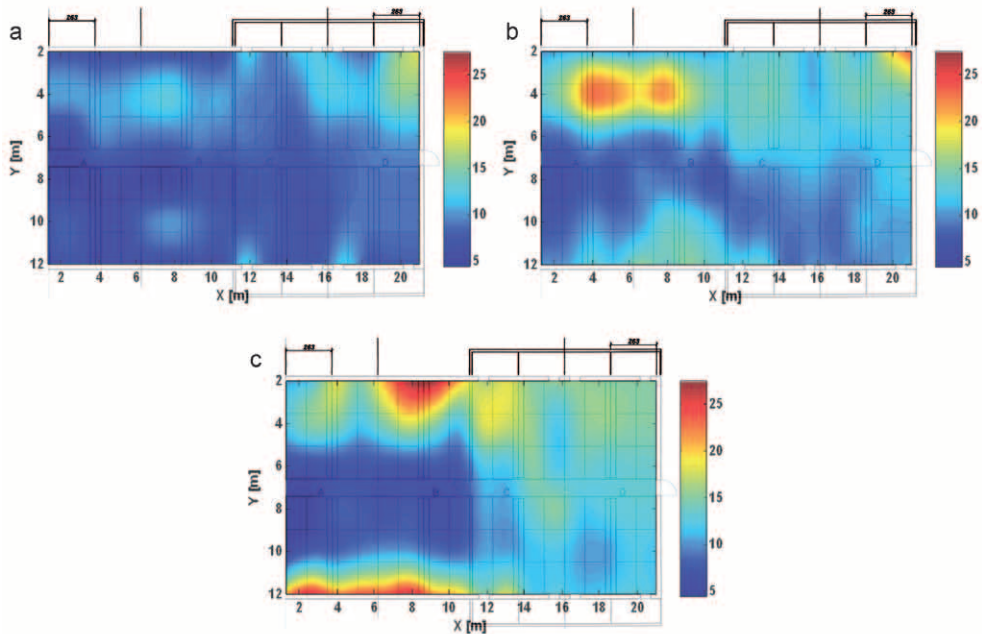

Figure 24.3. Daily mean values of light distribution in the barn at three heights: (a) 0 m, (b) 0.75 m and (c) 1.50 m from the floor, on the right in the figure the scale of light intensity (from blue= 5 lx to red=27 lx).

west side, without dunging areas, where light came primarily from the windows. The absence of windows in compartment 2 (areas C and D, pens 1 and 2, with dunging areas) prevented natural light from entering the building. The pen dividing walls with troughs were 0.80 m high, but the walls dividing the areas reached the ceiling. The same thing happened in the two compartments of the building oriented to the east. In this case, artificial lighting could not guarantee a sufficient level of light at animal eye level.

At 1.50 m (Figure 24.3c), equivalent to human eye level, the light intensity was noticeably higher, resulting from natural light coming from the windows in areas A and B and from the openings to the outside in areas C and D. Nevertheless, even at this height, the light level remained very low (<27 lx indicated by the red colour in the figure) and insufficient for a correct inspection of animals by the veterinarian or the farmer. The 3D gradients in light intensity measured in a single pen reached a value of 3.98 lx/m, while the gradient in a compartment reached 4.45 lx/m.

As stated earlier, pigs must be kept in light with an intensity of at least 40 lx for a minimum period of 8 h per day from 9:00 am to 5:00 pm (CEC, 2001), but the results obtained in this study from static measurements showed that in area B, illuminated only by natural light, the required light level was never reached. The same applied to the artificially illuminated areas, even though in this case the difference between the results obtained in this study and the required standard was minimal. The static measurements taken at human height showed that the threshold of 40 lx was

not reached, as a mean value, only in area B (Figure 24.2). The 3D measurements, conducted at six points in the pens at human height, revealed that the light intensity did not reach the mean value of 40 lx in all four areas. As shown in Figure 24.3, light intensity reached the maximum value of 27 lx indicated by the red colour.

Figure 24.4 shows an example of the three dimensional light and frequency distribution from the data collected at noon in a naturally illuminated pen (pen 2 in area B). This example was chosen because this was the darkest area in the building, based on analysis of the static measurements. The required intensity level of at least 40 lx of light intensity for a minimum period of 8 h per day was never reached. It is clear from this figure that the window in the upper left corner of the pen (2.0 m above the floor, 1.2 m wide and 0.6 m high) transmitted light to the pen. However, the penetration level of natural light into the pen was low. Only the area of the pen close to the window was slightly illuminated, down to a height of about 1 m from the floor. At the animals' height, the light intensity was very low, and the pigs did not receive any natural light. According to the histogram in Figure 24.4, high variations in light distribution occurred in this pen, from 27 to 4.5 lx over a horizontal distance of 3 m. Most of the positions in this pen had a light intensity of about 9 lx. Wider windows, or positioned closer to the floor, could improve the lighting of the pen, avoiding the use of artificial light.

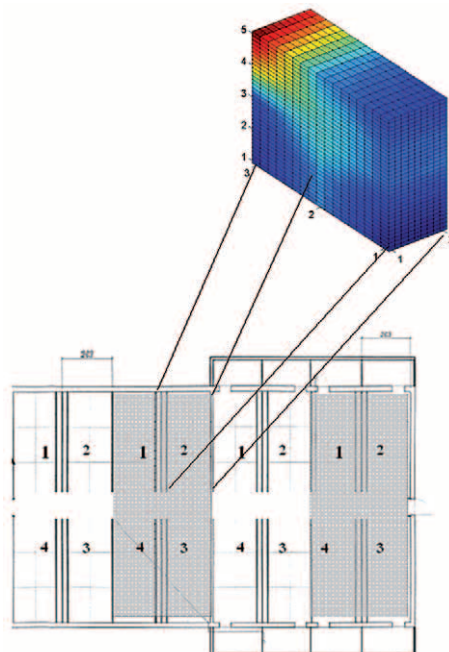

Figure 24.4. 3D distribution of light intensity and the histogram in a single pen which shows the volume of the zones as a function of the natural light conditions (area B, pen 2), upper in the figure the scale of light intensity (from blue = 5 lx to red = 27 lx).

A higher light level was reported in area D, which was also illuminated only by natural light, due to the presence of the dunging areas and the southern exposure. However, both artificially illuminated areas (A and C, see Figure 24.5) had higher light levels on average than the naturally illuminated areas (B and D, see Figure 24.6).

### 24.4 Conclusions

In this study, light intensity measurements were performed in a pig house. Static measurements were performed in the corridor at human level. 3D measures were conducted at ground (pig resting), animal (pig eye height) and human eye level in the pens.

The static measurements performed at the height of 1.5 m indicated that the light intensity of 40 lx, as required by EU rules for pig welfare, was reached 89% and 97% of the time respectively between 9:00 am and 5:00 pm in pens without dunging areas and in pens with dunging areas in the artificially illuminated areas of the building. In the naturally illuminated areas, the 40 lx level was never reached in pens without dunging areas, while light level between 9:00 am and 5:00 pm was met 83% of the time in pens with dunging areas.

The variability in light intensity measured inside the building depended mainly on the structure of the building, the position of the pen, and the orientation of the building. The light intensity was highly heterogeneous, with values 17 lx higher in the artificially illuminated areas (A and C),  $57 \pm 6$  lx (Mean  $\pm$  SD), in comparison with the naturally illuminated areas (B and D), and  $40 \pm 5.56$  lx (Mean  $\pm$  SD).



*Figure 24.5. Pigs reared in an artificially lit barn: animals are well illuminated, this condition is ideal for farmer's inspections.*



Figure 24.6. Light from a window in a naturally lit swine barn: pigs are almost in the dark during daylight time.

The results suggested that larger or better positioned windows could improve the illumination as well as artificial lighting, leading the farmer to save money, considering that the yearly cost of artificial light in a pig house is about 0.58 € per pig place. Otherwise, to obtain the required conditions while keeping artificial lighting energy costs to a minimum, a sensor could be used to turn the lights on when necessary.

The southern exposure of some pens, combined with the presence of openings for dunging areas, seemed to positively affect light intensity levels in those pens.

The analysis of the 3D light distribution, performed under clear sky conditions, revealed that the light intensity varied with height and was very low at all the levels, mainly at floor level (4.5 lx), during the day. Under these conditions, animal inspection by the farmer or veterinarian could be difficult. The 3D gradients in light intensity, or light intensity variation, measured in a single pen reached 3.98 lx/m, while the gradient in a compartment reached 4.45 lx/m, showing a non-homogeneous light distribution in the building.

Experience acquired by researchers in environmental and behavioural animal science shows the importance of differentiating between illumination measured in the environment and the light levels actually perceived by animals. A more detailed study is needed to investigate the distribution of natural and artificial light in pig houses to meet the required conditions for each period of life of the animals. Moreover, official standard rules must specify the procedure for measuring light intensity, and should reference the criteria used for adopting the standard.

## References

- Baldwin, B.A. and Meese, G.B., 1977. Sensory reinforcement and illumination preference in the domesticated pig. *Animal Behaviour* 25(2): 497-507.
- Baldwin, B.A. and Start, I.B., 1985. Illumination preferences of pigs. *Applied Animal Behaviour Science* 14(3): 233-243.
- Barnett, J.L., Cronin, G.M., McCallum, T.H. and Newman, E.A., 1994. Effects of food and time of day on aggression when grouping unfamiliar adult pigs. *Applied Animal Behaviour Science* 39(3-4): 339-347.
- CEC, 2001. Commission Directive 2001/93/EC of 9 November 2001 amending Directive 91/630/EEC: Laying down minimum standards for the protection of pigs. Commission of the European Communities, Brussels, Belgium.
- Christison, G.I., 1996. Dim light does not reduce fighting or wounding of newly mixed pigs at weaning. *Canadian Journal of Animal Science* 76(1): 141-143.
- Frederiksen, B., Nafstad, O., Lium, B.M., Marka, C.H., Dahl, D. and Choinski, J.U., 2006. Artificial light programmes in entire male pig production – effects on androstenone, skatole and animal welfare. *Acta Veterinaria Scandinavica* 48 (Suppl 1): 2.
- McGlone, J.J. and Curtis, S.E., 1985. Behaviour and performance of weanling pigs in pens equipped with hide areas. *Journal of Animal Science* 60(1): 20-24.
- Robbins, K.R., Adekunmi, A.A. and Shirley, H.V., 1984. The effect of light regime on growth and pattern of body fat accretion of broiler chickens. *Growth* 48(3): 269-277.
- SAS, 2008. SAS user's guide: statistics. Ver. 8.2. SAS Institute, Inc., Cary, NC, USA.
- SAS, 2011. SAS user's guide: statistics. Ver. 9.2. SAS Institute, Inc., Cary, NC, USA.
- Scientific Veterinary Committee, 1997. The welfare of intensively kept pigs. Document No. XXIV/B3/ScVC/0005/1997. Available at: [http://ec.europa.eu/food/fs/sc/oldcomm4/out17\\_en.pdf](http://ec.europa.eu/food/fs/sc/oldcomm4/out17_en.pdf).
- Stevenson, J.S., Pollmann, D.S., Davis, D.L. and Murphy, J.P., 1983. Influence of supplemental light on sow performance during and after lactation. *Journal of Animal Science* 56(6): 1282-1286.
- Taylor, N.R., Perry, G., Potter, M., Prescott, N.B. and Wathes, C.M., 2003. Preference of pigs for illuminance. In: Ferrante, V. and the Scientific Committee (eds.) *Proceedings 37<sup>th</sup> International Congress on Applied Ethology in Farm Animals*. International Society for Applied Ethology, Abano Terme, Italy, p. 165.
- Van Putten, G. 1968. Een onderzoek naar staarbijten bij mestmarkens. Ph.D. Thesis. University of Amsterdam, Amsterdam, the Netherlands.
- Van Putten, G. 1980. Objective observations on the behaviour of fattening pigs. *Animal Regulatory Studies* 3: 105-108.
- Van Putten, G. 1984. The influence of three levels of light on the behaviour of fattening pigs. *Applied Animal Behaviour Science* 13(1-2): 180.
- Van Putten, G. and Elshof, W.J., 1983. De invloed van licht op het welzijn van mestvarkens: een eerste indruk. *Bedrijfsontwikkeling* 14(2): 139-142.
- Van Rooijen, J. 1985. Possibilities and limitations of choice tests in relation to animal well-being. In: Unshelm, J., Van Putten, G and Zeeb, K. (eds.) *Proceedings International Congress on Applied Ethology in Farm Animals*. International Society for Applied Ethology, pp. 353-357.



## **Part 8**

# **Occupational and community health aspects of animal production**





## 25. Challenges to occupational and community health and the environment in animal production and housing: a North American perspective

*K.J. Donham*

*Iowa's Centre for Agricultural Safety and Health, Department of Occupational and Environmental Health, College of Public Health, University of Iowa, Iowa City, IA 52242, USA; [kelley-donham@uiowa.edu](mailto:kelley-donham@uiowa.edu)*

### Abstract

Public concerns relative to adverse consequences of livestock production have been increasingly voiced since the late 1960s. These concerns have been exacerbated by several demographic and social developments, including: (1) the percent of the general public in most industrialized countries involved in agriculture production (approximately 2%) is far outnumbered by the population not involved in agriculture (98%); (2) farming is generally no longer considered a 'special' industry by the general population in regards to environmental and social norms (e.g. supported and accepting of minor odours or other nuisances). This fact is heightened by the decline of traditional family farming relative to large scale production. Additional to general environmental concerns, occupational health of workers has become more relevant as many operations now have employees, which may bring them under the scrutiny of governmental occupational safety and health authorities. Livestock producers and their associations often criticize the claims of environmental and animal rights groups asserting that they lack science based evidence and are driven mainly by emotion. This chapter will explore the science basis of occupational, community, and environmental impacts associated with modern livestock production in industrialized countries. Further, recommendations will be made to help promote sustainability of livestock industry within the context of engineering and housing design that addresses human health and environmental issues, maintaining good stewardship of our environment and preservation of human capital.

**Keywords:** livestock, confinement facilities, dust, gases, health

### 25.1 Introduction

Since the ending of hunter gatherer societies and the beginning of agricultural societies some 15,000 years ago, there has been a trade-off between the process of producing food for society, and stress on the natural environment and the people that produce the food. Furthermore, the advent of the industrial revolution in the early 1800s charted a path of increasing productivity and intensification of agriculture and non-agriculture industries that has further stressed the health of the workers, the communities, and the natural environment. The latter not only challenges the urban environment, but also rural environments as urban discharges and emissions reach rural residents' via air and surface waters that connect urban and rural landscapes. As industrialized nations' economies grew strong and basic necessities of life were generally cared for, the political

and social controversies have increased as fewer of nations' populations are involved in agriculture (approximately 2% in developed countries) (Donham and Thelin, 2006).

Research has indicated that water and air pollution are now global issues, and agricultural production has been pulled into an international debate on environmental pollution as a contributor to the problem. As agricultural production has become more concentrated into larger and more intensive operations, awareness and attention has increased from the public and regulatory agencies regarding water, air, and soil contamination including related community and worker health concerns. Emotions are high among people who are concerned, complicating specific diagnoses for persons who claim to suffer health problems from these exposures. On the other hand, a large portion of the agriculture community feel threatened that their industry has been negatively portrayed, and they fear excessive regulation will unnecessarily burden the economic profitability of their operations, making it impossible to farm. Because of all these reasons, animal scientists, agriculture engineers, veterinarians, livestock producers, rural health and environmental professionals should be as (or even more) knowledgeable and concerned about worker health, community and environmental issues as are their urban counterparts. My objective is to review current scientific information to help create, to the extent possible, an unbiased awareness on the part of the reader enabling them to be better prepared to participate in informed public debate and provide information regarding the nature and prevention of resulting occupational, community health effects, and environmental concerns associated with livestock production and housing.

This author has previously reported on the concern of lack of inclusion of human health and environmental concerns as key issues in sustainability of agriculture (Donham, 1995; Donham and Thu, 1993). Savitz and Weber (2006) proposed a model for sustainable businesses that can be well suited to agriculture. They promote the concept of a 'triple bottom line' for long term sustainability of businesses. The triple bottom line integrates on equal footing, three building blocks; healthy humans (workers and public), healthy planet (minimal environmental pollution), and healthy profits. Although progress is being made in the building blocks of their model, consumers will continue to demand more attention to the health of the environment and the people the health of the environment and the people. We need to recognize that agricultural production is a dynamic industry shaped by global economic forces (Donham and Thu, 1993). New issues arise regularly, challenging the balance of the profit, people, and planet building blocks. Agricultural enterprises must be nimble in their management approach to recognize and practice management methods that will result in healthy people and planet in addition to healthy profits. (Done *et al.*, 2005; Lee *et al.*, 2005)

## **25.2 Types of animal feeding operations and associated housing**

There exists today a wide variance among livestock or poultry production methods and related housing. The big shift over the past three decades however, has been from smaller more outdoor to large more concentrated enclosed operations. There have also been buildings designed that provide a partially confined operation for moderate sized operations. Hoop structures are such an example used in some swine and beef operations. However, the predominant housing for livestock or poultry production in most industrialized countries involves enclosed confinement

## 25. Challenges to occupational and community health and the environment

structures associated with animal feeding operations (AFO). The US Environmental Protection Agency (EPA) has a specific definition of AFO that includes the confinement of animals for at least 45 days in a 12-month period, and in a structure or lot where vegetation or crops will not grow. The term: confined animal feeding operation (CAFO) is used to describe AFO over a specified size that are a risk as a point source for water pollution, and therefore require regulation (US EPA, 2002). In regard to occupational and community health, water, air, and solid waste pollution, there is no agricultural operation that is totally free from those issues. However, there are special concerns for CAFO because of the sheer size and concentration of animals (total number and number of animals per unit space) and related potential pollutants in a small area. Pollutants may include manure (usually handled in liquid form for swine and cattle), dead animals, flies, associated gases, particulates, odorants, pharmaceuticals used in production, and infectious diseases. There are concerns that the manure cannot be recycled completely, or other substances cannot be managed without pollution on such a small area, and that local and regional air and water quality therefore suffers (Thorne, 2007; Vos and Zonneveld, 1993). Because the vast majority of animals in industrialized countries are now raised in these CAFO-type facilities, they are the focus of concern from the public's point of view. Numerous publications, regional, national and international conferences and commissions have been held on the subject since 1994 (Merchant *et al.*, 2002; Pew Commission on Industrial Farm Animal Production, 2008; Thu, 1995; Thu and Durrenberger, 1998). When considering health effects on human beings of livestock operations, most people think of observable/objective signs and symptoms of illness or injury. However, the public health perspective on definition of health is much broader. The World Health Organization defines health as: '...a state of complete physical, mental, and social well-being and not merely the absence of disease or infirmity' (WHO, 1972). This (rather broad/inclusive) definition makes it difficult for agricultural producers to defend against claims of adverse health effects from livestock operations.

One reason large scale livestock production has raised public concern is that it has separated from traditional family farming and has developed like any other industry in management, structure, employment, and concentration. One of the public's concerns is that in the US there is 130 times more animal waste produced (by weight) yearly than human waste and this waste generally is not treated sanitarly as is human waste before it is returned to the environment (Esteban, 1998). In the subsequent discussion, a new review of the scientific literature is presented which builds onto and updates prior publications (Donham, 2010), with a focus on the occupational health of pork producers and employees, assessed health effects of air contaminants from swine CAFO on community residents, and the general contamination of the environment. Swine production facilities are emphasized here as a model as it has been the target of the bulk of the research and concern from the public's perspective, and has garnered the bulk of this author's professional experience. However, the reader should note that poultry, beef cattle and dairy operations have similar issues, but perhaps at a lower level of concern.

### 25.3 Occupational health of swine producers and employees

Research on the health and safety of people working in swine confinement environments first began in 1977 (Donham *et al.*, 1977). This research focus was advanced in subsequent years by many other researchers on several continents (Radon *et al.*, 2003). Potentially hazardous dust and

gases are present in many swine CAFO buildings. The following paragraphs will review the air exposures, their sources, known occupational health effects, and prevention.

### **25.3.1 Respiratory exposures and health risks**

CAFO dust is a complex mixture of agents that are generated primarily from the animals (hair and dander), dried faeces, and feed (Donham and Gustafson, 1982; Donham *et al.*, 1985a; Nilsson, 1984). Gases are generated inside the building from decomposition of animal urine and faeces (ammonia, hydrogen sulphide). In buildings with liquid manure storage under slatted floors, hydrogen sulphide and ammonia may be produced (along with numerous other gases of minor health concern). Furthermore, fossil fuel-burning heaters present in some farrowing, nursery, and poultry or chick facilities may emit carbon monoxide and carbon dioxide. The animals' respiration emits carbon dioxide and heat.

These dusts and gases may accumulate to concentrations that may be acutely or chronically hazardous to human and animal health. The mixture and concentrations of dusts and gases inside CAFO vary depending on numerous factors including management practices, ventilation and other engineering controls, the age, number and type of animals in the building, and the design and management of the feeding and waste handling systems. The relationship between these factors and pollutant levels were extensively studied in Australia (Banhazi *et al.*, 2009b) and Europe (Radon *et al.*, 2002) as well as North America (Donham, 2010).

Dust particles in swine CAFO consist of approximately 25% protein, and range in size from less than 2 µm to 50 µm in diameter (Donham *et al.*, 1985a,b), although there is variation regards to the specific source of the particles, and the livestock species. In general terms, one-third of the particles are within the inhalable size range (aerodynamic mean approximately 10 µm in diameter, and arise mainly from animal feed) (Donham *et al.*, 1985a; Nilsson, 1984). However, the sub-component of particles arising from faecal material is smaller (5 µm) relative to other dust components, and consists of high concentrations of gut-flora bacteria and exfoliated gut epithelium. This component of the dust constitutes a major burden to small airways and alveoli of the respiratory tract. The larger particles primarily impact the upper airways. Also present are animal dander, broken bits of hair, bacteria, endotoxins, pollen grains, insect parts, and fungal spores (Donham, 1986; Donham *et al.*, 1985a; Takai *et al.*, 1998). In recent years, researchers have focused on the microbial by-products contained in this dust, as the primary hazardous substances. Endotoxin, and (1-3) beta-D-glucan, originates respectively from the cell wall of gram-negative bacteria and certain yeasts, moulds, and bacteria (Seedorf *et al.*, 1998). They are toxins and inflammatory mediators. The dust absorbs ammonia and possibly other toxic or irritating gases adding to the potential hazards of the inhaled particles (Donham and Gustafson, 1982; Donham *et al.*, 1982b; Do Pico, 1986; Sigurdarson *et al.*, 2004). A recent study has shown that the mixed exposure to dust and ammonia in CAFO results in 2 to 4 times the respiratory health hazard (assessed by decline in pulmonary function over a work period) (Donham *et al.*, 2002).

In animal and poultry housing where manure is handled in a solid form, the potential gas emitted of health concern is ammonia (NH<sub>3</sub>) (Li *et al.*, 2011). However, where manure is stored and

## 25. Challenges to occupational and community health and the environment

handled in liquid form, at least 160 different gases are generated in anaerobically degenerating manure. Of these gases, hydrogen sulphide ( $\text{H}_2\text{S}$ ),  $\text{NH}_3$ , methane ( $\text{CH}_4$ ), carbon dioxide ( $\text{CO}_2$ ), and carbon monoxide ( $\text{CO}$ ) are primary health hazardous gases present (Donham *et al.*, 1982a,b, 1988; Donham and Gustafson, 1982; Donham and Popendorf, 1985). These gases may escape into the work environment in buildings with pits under the building, creating chronic and acute health hazards (Donham *et al.*, 1988b). Additional to  $\text{NH}_3$  emitted from the manure pit, 40% of the ammonia that has been measured in-building is released by bacterial action on urine and faeces on the confinement house floors (Donham and Gustafson, 1982). Methane, another emitted gas from liquid manure systems is not a toxic respiratory hazard in these buildings. However, methane may be an occasional fire or explosive hazard in some buildings.

### 25.3.2 Who is exposed to these pollutants, and when?

In the US, an estimated 700,000 persons work in livestock and poultry confinement operations (Donham, 1990). With a combined population of pigs in the US, the EU 15, and Canada, one can estimate there are 500,000 working in the pork production industry in these countries, all with similar production style and housing (Eurostat, 2012).

This number includes owner-operators, hired farm workers, women, children, veterinarians, and service technicians. There are an estimated 60,000 workers in swine production in Denmark, one of the highest pig producing countries in the EU. However, pigs are raised throughout the EU, and along with poultry, many people can be exposed. Figure 25.1, is a map of pig farms in the EU, and presents a relative view of where exposed owner/operators and workers would be located. Additional to Europe, the US, Canada, Brazil, Australia, China are among other major swine producing countries.

The risk of acute and chronic respiratory health effects in CAFO workers is related to their individual relative genetic susceptibility to endotoxin (Smit *et al.*, 2008) or allergens, the length of time the person has worked, whether the person smokes or not, whether they have other respiratory conditions, and the concentration of pollutants in these buildings. Although some individuals may have adverse health effects within the first week of work, most will not develop symptoms until they have worked more than two hours daily and for six or more years (Donham *et al.*, 1977, 2000; Donham and Gustafson, 1982).

Dust and gas concentrations increase in winter when the houses are tightly closed and ventilation rates reduced to conserve heat (Donham *et al.*, 1977). Also, dust concentrations increase when animals are being moved, handled, and fed, or when buildings are being cleaned by high-pressure spray washing or sweeping (Nilsson, 1984; O'Shaughnessy, 2012). Ventilation systems are designed to control heat and humidity in the building and often will not reduce dust or gas levels adequately to insure a healthy environment for humans. During the cold seasons, should the ventilation systems fail for several hours,  $\text{CO}_2$  from animal respiration, combined with  $\text{CO}_2$  and  $\text{CO}$  from area fossil fuel burning heaters and manure pits can rise to asphyxiating or toxic levels. In the warm seasons, the greater risk to animals from ventilation failure is heat stress from high temperature and humidity. These latter two situations are mainly animal health risks. They

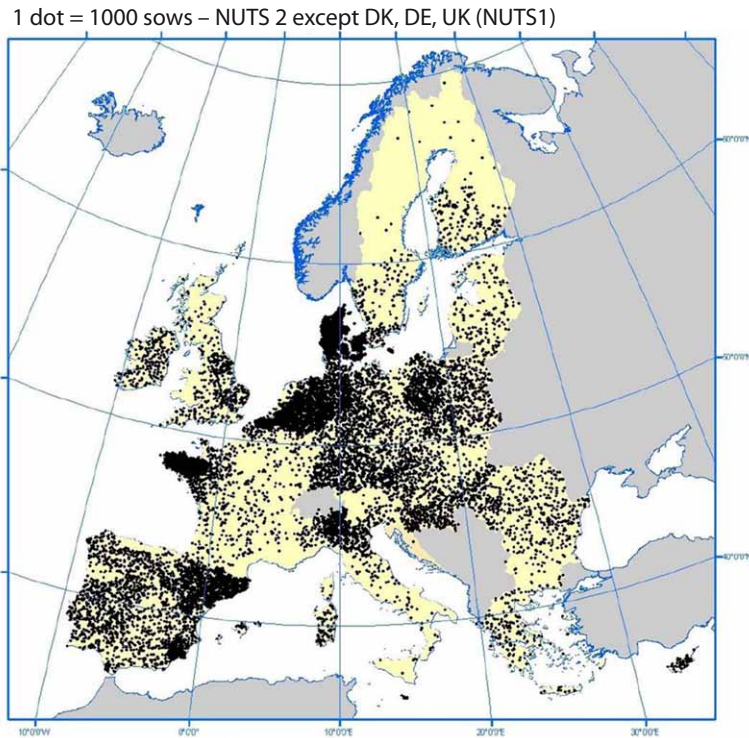

Figure 25.1. Concentration of swine production in the EU Countries (Eurostat, 2012: [http://epp.eurostat.ec.europa.eu/statistics\\_explained/index.php/Pig\\_farming\\_statistics](http://epp.eurostat.ec.europa.eu/statistics_explained/index.php/Pig_farming_statistics)).

would not create an acute human health threat, as they are not so acute as to prevent workers from leaving the building safely in time.

Hydrogen sulphide may pose an acute hazard whenever the liquid manure slurry is agitated within a confined space (Donham *et al.*, 1982b; Osborn and Crapo, 1981). During agitation, H<sub>2</sub>S can be suddenly released resulting in a rise in concentrations from usual ambient levels of less than 5 mg/m<sup>3</sup>, to lethal levels of over 500 mg/m<sup>3</sup> (Donham *et al.*, 1982b, 1988). The greater the agitation, the more rapid and greater concentration of H<sub>2</sub>S released. Animals and workers have died or become seriously ill in swine CAFO when H<sub>2</sub>S has risen to high concentrations from agitated manure in pits under the building. Several workers have died when entering a pit during or soon after the emptying process to repair pumping equipment or to clean out solids in a pit or sump, to retrieve tools or animals that have fallen in or to repair pit ventilation (Beaver and Field, 2007; Donham *et al.*, 1982b). Persons attempting to rescue these workers also have died (Donham *et al.*, 1982b). Hydrogen sulphide exposure is most hazardous when the manure pits are located beneath the houses. However, an acutely toxic environment may result from outside storage facilities or if gases backflow into a building due to inadequate gas traps or other design faults or if a worker enters a separate confined-space storage facility such as a manure slurry wagon.



### 25.3.3 How commonly do excessive exposures occur?

In the US, typical dust concentrations in swine CAFO are 2 to 6 mg/m<sup>3</sup> (Donham *et al.*, 1985a; O'Shaughnessy *et al.*, 2010). Concentrations of 10 to 15 mg/m<sup>3</sup> may be seen during cold weather or when moving or sorting the pigs (O'Shaughnessy *et al.*, 2012).

Based on research in Sweden and the US, maximum recommended safe concentrations of total dust is 2.5 mg/m<sup>3</sup> to prevent chronic respiratory conditions in pig producers and workers (37 mm closed-faced cassettes; or 4.5 mg/m<sup>3</sup> as measured with IOM sampler) (Donham *et al.*, 1995; Reynolds *et al.* 1996, 2009) which are considerably lower than the 15 mg/m<sup>3</sup> for nuisance dust set by the US Occupational Safety and Health Administration (OSHA) for industrial standards (limits in the EU and Australia are much lower, in the 5 mg range).

The majority of buildings exceed these recommended exposures during cool seasons (O'Shaughnessy *et al.*, 2012). The greater relative toxic nature of this organic dust is its high degree of biological activity, its inflammatory constituents (endotoxin and 1-3,β-D-glucans) and the additive and synergistic actions of the mixed dust and gas exposures. Nearly 60% of swine confinement workers who have worked for six or more years, experience one or more respiratory symptoms (Clark *et al.*, 1983; Donham *et al.*, 1984, 1989; Thedell *et al.*, 1980). Prevalence of respiratory symptoms among workers in CAFO is 25%, compared to about 12% in non-confinement swine workers, or 15% in grain farmers (Andersen *et al.*, 2004; Donham, 1990; Radon *et al.*, 2003).

### 25.3.4 Respiratory effects of inhaling confinement house dusts and gases

Human health effects of work in swine CAFO was first described by Donham *et al.* (1977). Since that time, numerous studies by many different authors in various countries have been published regarding the complex set or syndrome of respiratory responses that include symptoms of acute and chronic bronchitis, non-allergic occupational asthma, mucous membrane irritation, and organic dust toxic syndrome (Donham and Zejda, 1992; Donham *et al.*, 1989; Mustajabegovic *et al.*, 2001; Thelin *et al.*, 1984). These inflammatory and toxic processes may occur alone or in combination, resulting in one or perhaps several conditions simultaneously (Donham, 1991; Donham *et al.*, 1989; Prior *et al.*, 2001).

The risk and severity of symptoms in workers differ according to several biological and exposure variables. In general, the symptoms are more frequent and severe among smokers (Donham and Gustafson, 1982; Marmion *et al.*, 1990; Markowitz *et al.*, 1985) and in those working in larger swine operations (related to longer hours working inside CAFO buildings) or working in buildings with high levels of dusts and gases (Donham *et al.*, 1995, 2000; Reynolds *et al.*, 1996). Banhazi *et al.* (2008b) also identified a statistically significant relationship between piggery size and elevated levels of airborne pollutants in piggery buildings. Further, there is a marked variation in biological susceptibility to the inflammatory effects of endotoxin (which is a component of the cell wall of gram negative bacteria, and found in high concentrations inside swine and poultry buildings) (Smit *et al.*, 2008).



Although irreversible airways obstruction has not been a general finding in confinement house workers, there is objective evidence that long-term obstructive airways disease may be occurring. Pulmonary function studies show evidence of air trapping in the lungs. Lavage studies of bronchial fluids show a persistent leucocytosis, and sputum studies show persistent inflammatory cells, and epithelial cells (Djuricic *et al.*, 2001; Schwartz *et al.*, 1990). Baseline pulmonary function studies (forced vital capacity; FVC), forced expiratory volume in one second (FEV<sub>1</sub>) of healthy confinement workers usually do not differ significantly from those of workers in conventional swine buildings (Donham *et al.*, 1989, 1990). However, flow rates at 25% to 75% of lung volume (FEF<sub>25-75</sub>) are significantly lower. Furthermore, work shift declines in FEV<sub>1</sub> and flow rate values are seen in most confinement house workers following a 2 to 4 h exposure. These findings suggest that chronic obstructive pulmonary disease may occur among these workers in future years (Schwartz *et al.*, 1995). Although end-stage lung disease in CAFO workers has not yet been systematically studied, the authors have experienced many anecdotal case studies where workers have quit because of health reasons. One study of owner/operators revealed a dropout rate of 10% over a six-year period for respiratory health reasons (Holness *et al.*, 1987).

A point to note; objective findings of allergic asthma (also called atopic asthma) is rarely found in producers or workers from farms with swine house exposures. This is thought to be the result of early exposures in life to these dusts and thus the body's 'acceptance' of these foreign substances (hygiene hypothesis) (Ernst and Cormier, 2000; Riedler *et al.*, 2001). An additional explanation is that workers who are allergic may leave the job early, leaving a 'healthy workforce'.

Although respiratory exposures are extremely common among CAFO workers, there are several other occupational hazards that should be considered. There are certain infectious agents involving the respiratory tract that humans may contract from animals in CAFO. These include, but are not limited to, swine influenza, erysipeloid, *Streptococcus suis*, and methicillin resistant *Staphylococcus aureus* (Holness *et al.*, 1987, Smith *et al.*, 2009). Injuries to CAFO workers from animals, pinch points in gates and pens, cuts and needle sticks are common. Furthermore, high noise levels in these facilities can lead to noise-induced hearing loss. These hazards are discussed elsewhere in much more detail (Donham and Thelin, 2006: 221-223).

## **25.4 Prevention**

Regarding respiratory health, prevention must first aim to provide air quality in livestock buildings that is not hazardous to respiratory health. Through several on farm studies, on two different continents (North American and Europe), we have established recommended maximum exposure levels for swine and poultry housing. Table 25.1 lists these maximum exposure recommendations, relative to a general recommending body (American Conference of Governmental Industrial Hygienists; ACGIH), and a governmental regulatory agency (Occupational Safety and Health Administration; OSHA).

Achieving these levels of air quality first depends on the ability to quantitatively assess the air quality. In Australia, specialized equipment was developed especially designed for conducting air quality assessment on farms (Banhazi, 2009). Details of assessment methods and equipment are reviewed in Donham and Thelin (2006: 117-121). Improvements in air quality are based

## 25. Challenges to occupational and community health and the environment

Table 25.1. Recommended and legal exposure limits pertaining to CAFO dust and gases (Donham and Thelin, 2006: 100; Donham et al., 2000).

Airborne pollutants	Current Research – based maximum exposure recommendations for swine and poultry CAFO	Typical findings in CAFO	ACGIH <sup>1</sup> recommendations	US OSHA <sup>2</sup> permissible exposures limits
Total dust (mg/m <sup>3</sup> )	2.5	3-6	4	15
Inhalable dust (mg/m <sup>3</sup> )	0.23	0.5-1.5	-	-
Ammonia (ppm)	7	5-15	25	50
Hydrogen sulphide (mg/m <sup>3</sup> ) -		0.5-5	10	10
Carbon dioxide (mg/m <sup>3</sup> )	1,500	1000-4,000	5,000	5,000
Endotoxin (EU)	100	50-1000	-	-

<sup>1</sup> American Conference of Governmental Industrial Hygienists.

<sup>2</sup> Occupational Safety and Health Administration.

<sup>3</sup> Dust as measured gravimetrically using closed-faced 37 mm cassettes (note using IOM cassettes, adjust the concentrations by dividing by 0.56).

on a comprehensive management system, including the following components: (1) decreased generation of dusts and gases by improved management procedures and engineering controls; (2) dilution of contaminants once in the air, e.g. ventilation; and (3) proper protection of the individual with respirator use. A prevention model for confinement house problems, based on education and industrial hygiene consultation has demonstrated its effectiveness (Donham *et al.*, 1990). Some examples of management practices to reduce the sources of dusts and gases include: (1) delivering feed by extension spouts into covered feeders, rather than letting feed fall freely a meter or more from automatic delivery systems into open feeders; (2) using extra fat or oil (1%) in the feed to reduce dust; (3) sprinkling or misting the environment with vegetable-based oil; (4) regular (every three to four weeks) washing buildings with power sprayers (operators must use respiratory protection during this procedure); (5) using flooring which is relatively self-cleaning (e.g. plastic-coated wire mesh); and (6) assuring that heating units are clean, vented, and functioning properly. Details of control measures are published elsewhere (Banhazi *et al.*, 2008a, 2009a,b; Donham, 1991). Effectiveness of control techniques can be assessed by measuring dust and gas concentrations. These buildings should be routinely monitored to assure air contaminants are within safe limits.

Because it is economically impossible to completely eliminate the formation of dusts and gases in CAFO, techniques for removing contaminants from the air of confinement houses are critically important. Ventilation can help dilute dusts and gases, to minimal hazardous levels. Ventilation systems must be properly designed and maintained, and ventilation rates adjusted to include

consideration of air quality. Operators often keep these rates too low in winter because of concerns for conserving heat, causing dust and gas concentrations to rise. A number of engineering techniques (e.g. use of heat exchangers which allow increased ventilation while capturing some waste heat) have been tried with varying degrees of success (Donham, 1993).

We only recommend wearing respirators as an adjunct to environmental control. Even if the concentrations of dusts and gases are below recommended limits, we recommend that anyone working in a swine or poultry confinement house for two or more hours in a day should be advised, at a minimum, to wear a National Institute for Occupational Safety and Health (NIOSH) approved N-95 two strapped dust mask. Recent research has shown that different tasks in pork production operations have greater exposures than others. As it is inconvenient and uncomfortable for workers to wear respirators 100% of the time while working, we recommended wearing dust respirators at a minimum during the following tasks: (1) processing piglets; (2) feeding; (3) moving and sorting hogs; and (4) load out (O'Shaughnessy *et al.*, 2010). Persons exposed to houses with high dust or gas concentrations, or persons with respiratory conditions, may need to use a more sophisticated respirator, such as a half-mask cartridge respirator or powered air supplying respirator (e.g. 3M air helmet). Proper selection and fitting of respirators for CAFO work are reviewed in detail in Donham and Thelin (2006: 121-129).

Preventing exposure to high concentrations of H<sub>2</sub>S from manure pits requires stringent controls. General safety measures include constructing manure pits outside of the confinement building, constructing openings so that lids or other objects cannot fall into the pit requiring a worker to enter the pit for retrieval, and erecting safety guards around open pits and warning signs. Whenever a pit that is under a confinement house is being agitated, people should stay out of the building, ventilation of the house should be maximized, and animals should be removed or observed from outside the building.

Even when not being agitated, manure pits can seldom be entered safely. If entrance is imperative, adequate protection is only assured when a self-contained breathing apparatus is worn by an individual trained in its use. All operators should understand that high concentrations of H<sub>2</sub>S cannot be smelled and that H<sub>2</sub>S above 1,000 mg/m<sup>3</sup> produces unconsciousness and respiratory arrest in only one to three breaths. A variety of H<sub>2</sub>S gas alarms give an accurate indication of hazard.

Poor air quality in the confinement house has also been shown to be associated with health problems and lowered productivity in the swine (Donham, 1991). Advising this economic fact to a swine producer may be the most expedient way to create environmental improvement that would help the person, the animals, and the economics of the operation. Two relevant comprehensive multi-factored prevention programs (Swine Confinement and Respiratory Health Project, and the Certified Safe Farm) have been trialled with success in pork production. (Ferguson *et al.*, 1989; Gjerde *et al.*, 1991; Kline *et al.*, 2007).

These programs incorporate the combination of environmental assessment, education, health screening, safety audit, health and safety goals setting, with incentives for achieving objectives. These programs work to reduce the risks of adverse occupationally – related health incidents,

## 25. Challenges to occupational and community health and the environment

and they reduce health care costs to address them. However, they do require a management commitment and resources to administer and maintain them. This author thinks there is sufficient science-based recommendations and program examples to guide this action, and advances are being made in the industry in this regard. However, it seems apparent that broader and more integrated implementation is a work in progress which should be encouraged.

### 25.5 Community health issues

#### 25.5.1 Air emissions from CAFO

Merkel *et al.* (1969) published the first qualitative assessment of gases emitted from liquid swine manure. Nearly 200 compounds emitted from animal manure have been detected (O'Neill and Phillips, 1992). These compounds can be grouped into the following chemical classes: mercaptans, sulphides, disulphides, amines, organic acids, phenols, alcohols, ketones, indoles, skatoles, carbonyls, esters, and nitrogen heterocyclics. The health risks of most of these substances (at the concentrations present) are not known. Some of these substances have a very low odour threshold (e.g. 1 µg/m<sup>3</sup>). Ammonia and hydrogen sulphide are the most important health significant emissions from livestock waste in regards to direct human health risks. Methane as well as carbon dioxide are important greenhouse gases.

The primary sources of gaseous compounds originate from the degradation of faeces and urine applied to land and from animal wastes stored in liquid or solid phase. Ammonia is a by-product of almost any treatment method of animal waste. Other fixed compounds and trace compounds come primarily from the anaerobic decomposition of manure in liquid storage systems.

In addition to gases, often overlooked are the particulate substances that are emitted from livestock feeding operations. There is a large quantity of organic dust generated from feed sources and the pigs (e.g. hair, dander, and dried faeces). This dust contains the bioactive substances endotoxin and glucans (Donham *et al.*, 1986). Also, there is a bio-aerosol component of this dust. Many Gram negative and Gram positive bacteria, fungi, and moulds have been identified (Thorne *et al.*, 1992). Some of these organisms also grow within confinement buildings, contributing to concentrations of organisms that are also found in the air outside the building (Kiekhaefer, 1995). The vast majority of organisms identified in the air are saprophytic and very few pathogens are identified. They are combined with dust that becomes a part of the total aerosolized particulates. The size of the particulates emitted is relatively small. About 50% are less than 10 microns, which means they are inhalable (will penetrate to the airways).

#### 25.5.2 Odours, odorants and particulates

Most of the public concern on CAFO has been about odour (Nimmermark, 2004; Radon *et al.*, 2004). An odour is an unpleasant sensation in the presence of an odorous substance (odorant). The odorant may or may not have additional harmful toxic effects. Ritter and Chirnside (1984) identified the classes of compounds from animal manure which are odorants, as previously mentioned. Ammonia and hydrogen sulphide among the fixed gases are also odorants.

Riskowski (1991) described an odour phenomenon associated with the livestock environments where ammonia and hydrogen sulphide are detected at much lower odour threshold concentrations than previously published; apparently due to interactions within the mixture of emitted chemicals and particulates.

Researchers have looked at the fixed gases (e.g. ammonia and hydrogen sulphide) as potential surrogates for emissions and odours. However, the results of several researchers have shown that there is a poor correlation between ammonia and hydrogen sulphide and odour strength (Payne, 1994; Smith and Kelly, 1996).

Goodrich (1975) has shown, relative to background, a very high level of viable organisms downwind of manure sprinklers, as well as inside beef and turkey facilities. Pickerel (1991) has shown swine barn environments to have significantly greater particle and microbe concentrations compared to other livestock environments. These concentrations are up to  $10^6$  times greater inside swine buildings compared to outside (Kiekhaefer, 1995). Very little is known about hazardous concentrations of odorants in outdoor air around CAFO. We do know there are worker health problems caused by  $H_2S$  and  $NH_3$  and dust in the interior. However, it is difficult to infer health risks outside these buildings based on occupational health studies. Available data (Reynolds *et al.*, 1997) suggests  $NH_3$  and  $H_2S$  are on the order of  $10^3$  times greater inside buildings compared to outside.

Concerns about odours from livestock facilities can be considered a nuisance, which is often how courts treat them. However, there is growing evidence that odours may cause physical illness (Nimmermark, 2004; Radon *et al.*, 2004; Wing *et al.*, 2008). Overcash *et al.* (1983) indicated odours may cause nausea, vomiting, headache, shallow breathing, coughing, sleep disorders, upset stomach, appetite depression, irritated eyes, nose and throat irritation, mood disturbances including agitation, annoyance, and depression. Ackerman (1990) reported odours can result in strong emotional and physical responses, particularly after repeated exposures. Schiffman *et al.* (1995) studied the profile of mood states of 44 people living near large animal facilities. Compared to controls they found that people living near the facilities were more angry, confused, tense, depressed and fatigued. In order to determine acceptable odours relative to distance from the source, Walsh *et al.* (1995) surveyed persons living in a 5 km area surrounding a large cattle feed lot. They measured odours according to an odour panel and found acceptable odour levels within the 5 km radius. Results of other research suggest that the physical symptoms (more relevant to worker exposure than community residents) may also be caused by chronic inflammation, secondary to inhaled dust and gases (Donham *et al.*, 1995; Pickrell, 1991).

### **25.5.3 Physical health**

When considering the health hazards of residents living in the vicinity of CAFO, there is relatively sparse dose-response or objective evidence of physical damage to human tissues from air emissions. For example, Jacobson (1997) and Davidson *et al.* (1987) reported  $H_2S$  levels in the vicinity of CAFO, well under the threshold limit value (TLV) for occupational health set at  $10 \text{ mg/m}^3$ . Also, in a study by Reynolds *et al.* (1997) levels of ammonia in the vicinity of swine CAFO were generally less than  $1 \text{ mg/m}^3$ . Concentrations of endotoxin and dust were near the

## 25. Challenges to occupational and community health and the environment

lower limits of detection of the instrumentation used (which was around 10 endotoxin units/m<sup>3</sup> of air, and dust less than 0.5 mg/m<sup>3</sup>). However, several studies have reported findings of excess respiratory symptoms in community residents compared to controls, including symptoms of bronchitis and asthma (Merchant *et al.*, 2005; Radon *et al.*, 2007).

Possible reasons for this observation include the fact that residents live in the area more than 8 hours per day. Also, there may be vulnerable populations who react at much lower levels than occupational limits. For example, several states have limits for hydrogen sulphide at 20 to 50 µg/m<sup>3</sup> three orders of magnitudes below the occupational exposure limit, and most federal agencies limits for environmental exposure (30 µg/m<sup>3</sup>) (Merchant *et al.*, 2002).

Kilburn (1996) reported on neurobehavioral effects of hydrogen sulphide gas. This small study reported neurological deficits in 16 exposed persons, including: decreases in balance, reaction times, visual field performance, colour discrimination, hearing, cognition, motor speed, verbal recall, and mood states. H<sub>2</sub>S is a toxin with several effects, including tissue irritation and poisoning of cellular respiration mechanisms with a predilection for brain cells. However, health effect of chronic low level H<sub>2</sub>S exposure remains uncertain.

Several studies of physical and mental health concerns of residents near CAFO have reported similar findings. These were controlled studies of self-reported symptoms and no attempts were made to document objective correlates of health impairment (Schiffman *et al.*, 1995; Thu *et al.*, 1997; Wing and Wolf, 2000). Thu *et al.* (1997) reported respiratory symptoms (significant relative to comparison populations controls) almost identical in type and pattern to workers in CAFO. Schiffman *et al.* (1995) reported excessive mood alterations in CAFO neighbours. There are numerous instances of similar studies in other environmental settings, including community concerns around paper pulp mills, hazardous waste sites, refineries, and solid waste disposal sites. Although most of these studies have not documented objective findings of toxic physical insult to humans, a few studies have reported subtle findings such as increased concentrations of urinary catecholamine or mucosal immune alterations (Avery *et al.*, 2004). Additionally, most of these studies have not shown evidence of known toxic concentrations of substances in the environment.

### 25.5.4 Extra-toxic mechanisms

Although the concentrations of potentially hazardous air contaminants are usually below known harmful levels, adverse health symptoms are commonly reported by community residents. One possible explanation for this is the phenomenon described by one researcher as 'extra-toxic effects' of low levels of emissions (Shusterman, 1992; Shusterman *et al.*, 1988). This literature has focused on trying to explain symptoms of community members who may be exposed to waste sites, sewage treatment plants, and other large population-based community exposures. Medical research and regulatory agencies have difficulty dealing with these situations, as they are not clear-cut. Clear-cut would include an objective finding (e.g. a measureable effect such as an altered blood chemistry or abnormal radiograph) of an adverse health effect, measured toxic substances at known toxic concentration, and an obvious dose response relationship. These community exposures are much more complex, as they are a mix of physical, mental, emotional, and social

stressors. ‘Genetic memory’ and other very basic limbic-level self-preservation mechanisms may be involved. The following paragraphs will review some of the literature that helps to explain adverse health symptoms that people in the community may experience where there is an absence of objective health and toxicological data.

### **25.5.5 The somatization of adverse odours**

Two different cranial nerves innervate the nasal mucosa: the first cranial nerve (i.e. olfactory) and the fifth cranial nerve (i.e. trigeminus) (Shusterman, 1992). The olfactory nerve is primarily responsible for odour detection. The trigeminus nerve has many branches that penetrate the oral mucosa and provides additional information to the brain on odour sensation such as irritation or pungency, which triggers protective responses, including decreased respiratory rate, rhinitis, tearing, cough, gag reflex, and bronchoconstriction. These are all warning indicators that something associated with the odour may be harmful and our genetic-based ‘instinctive protective’ mechanisms telling us to make physiologic changes to meet the impending insult, or to get out of the area (Shusterman, 1992; Shusterman *et al.*, 1988). Therefore, it makes sense that odours can result in symptoms of mucosal irritation including respiratory symptoms, nausea, and feelings of ‘disease’ (Shusterman, 1992; Shusterman *et al.*, 1988).

Complexed with these physiological responses to low level irritants and odours, there are behavioural interactions (e.g. perceived loss of property value, loss of control of one’s personal space) that may explain health symptoms of illness associated with odours. There are five theoretical mechanisms for extra-toxic odour-related physical symptoms (Shusterman, 1992).

#### *Innate odour aversions*

As a basic protective mechanism, our body wants to avoid certain odours that may signify potential harm. For example, odours in putrefaction gases (e.g. H<sub>2</sub>S, mercaptans, and other sulphur-containing chemicals) are common substances that stimulate physiologic effect and the drive to avert from those substances at lower than toxic levels. These gases may be associated with spoiled food, but are also associated with animal manure, as are many of the odours associated with these innate odour responses.

#### *Negation of normal pheromone phenomena*

Pheromones stimulate physiologic responses, especially around sexual reproduction. These are most overt for insects, but many mammals, including humans respond to them. Some odours might destroy normal positive pheromone responses resulting in impaired sexual function for people living in the vicinity of CAFO. (Shusterman, 1992; Shusterman *et al.*, 1988)

#### *Exacerbation of underlying conditions*

Previous research has shown that workers with underlying conditions (e.g. asthma, atopy, bronchitis, heart conditions) are more susceptible to the CAFO environment than others (Schiffman *et al.*, 1995). Furthermore, it is now evident that individuals genetically differ in



## 25. Challenges to occupational and community health and the environment

their susceptibility to endotoxins. Research by a number of researchers (Meggs, 1997; Meggs *et al.*, 1996; Rylander, 2004) also lends strength to the theory that underlying conditions (such as asthma) may amplify exposures.

### *Aversive conditioning*

Some people previously exposed to high levels of odorous gases, causing toxic effects, may respond physiologically to less than toxic levels (i.e. slight odour) of this substance in future exposures. The condition described as multiple chemical sensitivity may have similarities to aversive conditioning (Bell *et al.*, 1992).

This author has observed this condition in several cases of CAFO workers who experience symptoms and anxiety when smelling CAFO odours following a severe CAFO gas exposure episode. This conditioned stimulus is probably an innate protective mechanism. This can also happen with lower level exposures over a long period of time (acquired odour intolerance) (Meggs, 1997; Meggs *et al.*, 1996).

### *Stress-induced illness*

Odour-related stress-induced illness has been discussed as a component of 'environmental stress syndrome'. This phenomenon has been seen following disaster sites such as Three Mile Island (Shusterman *et al.*, 1988). Studies have shown there is increased urinary catecholamine in the affected individuals. They also have a feeling of depression, helplessness, and a high degree of environmental worry which is exacerbated by detection of the offending odour. Community members may be excessively worried that their property values are falling because of the odour source in their neighbourhood. Odours can act as a cue for these individuals stimulating adverse physiologic risks relative to an associated exposure. Long-term stress can be associated with muscle tension, headaches, coronary artery disease and peptic ulcers.

### *Summary of extra-toxic mechanisms*

In studies of physical health complaints in communities around CAFO, it would be expected that objective findings of toxicity would be difficult to obtain. However, that does not and should not discount the fact that people experience valid symptoms. The reasons have to do with complex interactions of the brain and somatic systems. First of all, odours may initiate somatic symptoms based on enervations of the trigeminal nerve. Furthermore, odours may initiate physiologic activity in response to primordially-acquired (limbic-level) aversions to toxic substances. These responses may be modulated and exacerbated by the person as they generally worry about environmental threats and the frequency with which odours are experienced. Furthermore, these conditions may be exacerbated by previous toxic exposures to the substances in question, creating a learned response of avoidance even when very low exposures are present. Further exacerbation may occur when combined with a feeling that the person has no control over their situation, with fears of declining property values. The combined physical and psychological effects have been described as resulting in 'environmental stress syndrome'. If an individual has an underlying health condition, such as asthma, further complications may be present.



## 25.6 Environmental pollution concerns

### 25.6.1 Animal wastes and inorganic fertilizers

Although it is difficult to quantify sources of water contaminants from agriculture and non-agriculture activities, livestock production is an important source of water and air contamination. Environmental contaminants from livestock production include products found in animal wastes (e.g. nitrogen compounds, phosphorus, particles, chloride, calcium, magnesium, antibiotics, microbes, antibiotic resistant genetic material and veterinary pharmaceuticals, etc.). The first six of these compounds (note that crop production is a major contributor of these substances as well as livestock production) have been called the 'foot print' of agriculture water pollution (Hamilton and Helsel, 1995). Nitrates and phosphorus are the most important elements of this foot print. The latter three have relatively little environmental health consequence. Manure is typically directly applied to land as a plant nutrient, and it contains relatively high concentrations of nitrogen and phosphorus (depending on animal species and prior treatments). Other pollutants associated with manure include potassium, microbes (some of which might be antibiotic resistant), and veterinary pharmaceuticals. A more detailed discussion of each of these follows.

### 25.6.2 Nitrates

As nitrogen is a fundamental element of life, recycling of nitrogen (the nitrogen cycle) is a fundamental ecologic principle. The nitrogen in the air (and soil) is 'fixed' by special soil bacteria into nitrate or ammonia, which can be taken up by plants as a food source. Plants fed to animals are digested and the nitrogen is incorporated into animal proteins. The nitrogen is then recycled to the air and soil as animal waste is applied to soil. The process of nitrification and denitrification by bacteria in our soils and waters convert this nitrogen to ammonia, nitrate and other oxidized forms (primarily nitrous and nitric oxide), and finally to nitrogen gas ( $N_2$ ) and back to the atmosphere. However, when nitrogen sources are added to fields faster than plants can utilize it, one of the major breakdown products (nitrate [ $NO_3$ ]) accumulates. Nitrate is very susceptible to run off to rivers and lakes or finally the oceans, or into our ground waters. Nitrate, when consumed (such as in contaminated water), will be reduced to nitrite in the GI tract of animals, which combines with haemoglobin to form methemoglobin, which cannot carry oxygen. Furthermore there are concerns of nitrites combining with amino acids or the herbicide atrazine in the gut to form carcinogens.

The nitrogen cycle is out of balance in a large part of agriculture in industrialized and in some developing countries. Although non-agricultural industry and auto exhaust are significant nitrogen sources, agriculture makes up 86% of the human generated nitrogen. The quantity of applied fertilizer is increasing, as 50% of fertilizer ever applied to crops has been applied since 1984. Only 50% of the applied nitrogen ever reaches plant tissues (Follett and Delgado, 2002). The remainder escapes by runoff or volatilization to overburden the nitrogen cycle. The problem has advanced strongly as our agriculture systems have evolved from small diversified low input operations to larger more intensive monoculture operations dependent on larger amounts of fertilizers and crop protection products. The pollution from land application is exacerbated by tiling, and other drainage techniques that increase the speed of water in

## 25. Challenges to occupational and community health and the environment

watersheds, reduced water recharge capacity, excess water runoff, less surface foliage, and more soil erosion (Novotny, 1999).

### 25.6.3 Phosphorus

Second to nitrate, phosphorus (P) is the most ubiquitous agricultural environmental pollutant. It travels with nitrate as its main sources are from inorganic crop fertilizers, and animal manures. Phosphorus is a component of manure, and exists in a ratio of around 10:1 with nitrogen. However, plants utilize about 7 parts of N to about 1 part of P resulting in a build-up of P in soils, if manure is applied to meet N requirements (Donham, 2000). An excess of P is often left, which is not highly soluble, and tends to be stored in soil, to the point where it reduces water filtration capacity and degrades the fertility of the soil for many years. Furthermore, P may leave the farm as run off, primarily with eroded soil, to contaminate surface waters. An example of how serious degraded soil fertility can become, a large number of acres of the Netherlands (a country with high pig production and small land mass) is degraded because of excess P, from excessive animal manure applications. Regulations have been developed in response to this concern (Wossick, 2008).

Most industrialized countries have environmental regulations that guide the amount of animal manure and inorganic fertilizers that can be applied to land so as to prevent excess N and P to the soils. However, enforcement of these regulations is challenged by the numerous farms, relative to the number of enforcement personnel. Although most producers are conservation minded, there are some who either by choice or accident may over apply N and P, resulting in soil, water and air contamination.

### 25.6.4 Trace elements

Sodium (Na), potassium (K), copper (Cu), and zinc (Zn) are found in animal manure as they are additives to animal feeds, often at levels higher than the animal is capable of metabolizing. Although there is probably no toxic health hazards to humans from this kind of exposure, there are problems with soil fertility degradation or eutrophication and from toxicity to grazing animals (mainly Cu).

### 25.6.5 Microbes

Microbial contamination of ground and surface waters can occur from livestock operations. Organisms that have been associated with animal waste with human health implications include *Helicobacter pylori*, (Lee, 1993) *Campylobacter*, *Salmonella*, *Cryptosporidium*, *Listeria* (Fayer, 1998); and *Salmonella* Typhimurium (Fone and Barker, 1994). Although there may be hundreds of species of organisms found in swine waste, it is important to note that most pathogens do not survive in animal wastes very long because they are not well suited to survive desiccation, sunlight, low pH, high osmolality and high ammonia concentrations in stored swine waste slurry (Donham and Dauge, 1985; Donham *et al.*, 1988) For example, *Salmonella* and *Leptospira* species were found to survive only 3 days in swine waste (Will and Diesch, 1972), or 19 days (*Salmonella*) in poultry manure and longer in cattle slurry (Berkowitz *et al.*, 1974; Bitton and Harvey, 1992).

Survival of organisms after land application is only a few days and is retarded by low temperatures, low soil moisture, low pH, sunlight, and competition with other organisms.

### **25.6.6 Antibiotics**

Field studies in the vicinity of poultry and swine confinement facilities have revealed the presence of antibiotics in a variety of water sources, including lagoons, monitoring wells, field tiles, streams, and rivers. The following antibiotics were found at a concentration of around 100 micrograms/litre of water: tetracyclines, sulpha,beta-lactams (e.g. penicillin), macrolids (e.g. erythromycin), and fluroquinolones (e.g. enterofloxacin) (Campagnolo *et al.*, 2002). It is fairly evident that there is a risk for consumption of antibiotics and antibiotic resistant organisms in well or surface waters, from runoff or seepage into the ground waters from CAFO. The health significance of consumption of these levels of antibiotics in water is uncertain. However, the risk is comprised of cumulative exposures, included with other sources of antibiotics and antibiotic resistant organisms.

### **25.6.7 Veterinary pharmaceuticals**

Small quantities of antibiotics, paracitocides, and growth enhancers (or their by-products) pass in the urine or faeces of animals and find their way to soils and water sources through manure application. However, relatively little is known about the fate and environmental impact of these substances. Perhaps the primary concern for environmental health is from excessive antibiotic use and possible influence on emerging antibiotic-resistant organisms. Generally, pharmaceuticals are a potential concern, but are secondary in importance to nitrogen, volatile organic compounds and pathogens.

## **25.7 Summary**

Public concerns relative to adverse consequences of large scale livestock production have been increasingly voiced since the late 1960s. A review of the literature on the occupational, community health and environmental concerns of current large scale livestock production systems and associated housing was conducted. The industry has recognized the public's concerns, and the livestock production industry and related governmental institutions are including these issues as an important component of their research and policy priorities. Critical to the sustainability of large scale livestock production is adoption and practice of Savitz and Weber's three pronged principle of business sustainability; people health (workers and community), planet health (environmental stewardship), and of course healthy profits. In this author's opinion, current research in environmental controls with livestock production is adequate to achieve Savitz and Weber's people and planet goals, if they are applied and managed properly. However, they are not practiced widely enough at this time. Further, facilities are still not designed to control indoor dust and gases to published target maximum exposure concentrations for worker health. New construction and management of livestock housing often does not deploy optimal research to practice. Evidence and recommendations are made in this review that hopefully will address these issues. In this chapter, the scientific literature was reviewed and recommendations were made to help promote sustainability of livestock industries within the context of engineering

## 25. Challenges to occupational and community health and the environment

and housing designing that addresses human health and environmental issues, maintains good stewardship of the environment and preserves human capital. The following dot-points help to summarize actions that may be taken to help limit occupational and community exposures, and promote sustainability. These points are a combination of both prior research, and experience based on consulting work within the industry.

### 25.7.1 Summary of control and prevention strategies

The following section will summarize a broad and conceptual overview of control and prevention methods, from a public health and industrial hygiene perspective. The general concepts of this strategy could apply to any type/species of livestock housing.

Control and prevention of environmental exposures within a building and emissions to the outdoors can be divided into three compartments: (1) the contaminant source; (2) the pathway to the worker or outdoors; and (3) the individual person/worker (Donham, 1989).

The source of the contaminant has to be considered. All too often most control mitigation strategies have focused excessively on the pathway. Source of swine contaminants include the animals (urine, manure, exfoliated skins cells and hair fibres (among others), and the feed. These contaminants can be divided into dusts, and gases (Banhazi *et al.*, 2008a,b; Cambra-Lopez *et al.*, 2010; Li *et al.*, 2011; O'Shaughnessy *et al.*, 2012). The following outlines the principle methods of source; pathway, individual, and emission control have been investigated.

#### 1. Source control

- a. Dust source control (Donham, 1989)
  - i. Routine high pressure washing of building (the whole building, crates, and floor) between lots of pigs (all in all out systems)
  - ii. Additional oil to feed sources (1%)
  - iii. Assure proper ventilation without area drafts or dead spaces
  - iv. Proper veterinary management to control lice, mange, and enhance good skin condition
  - v. Maintain indoor humidity between 50 and 70%
  - vi. Install oil emulsion sprinkling system (Nonnenman, 2004)
- b. Gas source control (Donham, 1989)
  - i. Ammonia
    - Routine power washing
    - Urease inhibitor to slurry (with pit under slats)
    - Assure flooring materials clean easily (eg. plastic or smooth concrete) (Hamelin *et al.*, 2010)
    - For pit under slats, or gutter flush, assure pit does not become over concentrated, and run fresh water over gutters following flushing
  - ii. Hydrogen sulphide (Donham *et al.*, 1982b; Osbern and Crapo, 1981)
    - Provide as minimal agitation as possible when emptying the pit
    - Monitor pH of pit to keep between 7 and 8
    - Add slacked lime if excessive acid (pH 5 or below)

## K.J. Donham

- Avoid water source to building with sulphates >500 mg/l (will contribute to excess hydrogen sulphide concentrations)

### 2. Pathway control

- Conduct routine air quality monitoring (both warm and cold seasons) for aerosolized dust, ammonia, and hydrogen sulphide (Donham, 2000)
- Assure proper functioning and maintenance of ventilation, and manage ventilation to control dust and gases according to the following – dust <2.5 mg/m<sup>3</sup> (37 mm open-faced cassette, or 3.6 mg/m<sup>3</sup> AOM sampler) (O’Shaughnessy *et al.*, 2010)
- Use a dry or wet electrostatic precipitation system (Almuhanna *et al.*, 2009, Chai *et al.*, 2009)

### 3. Individual control (note this is the lowest level of protection and not to be used in as a substitute for source and pathway control)

- Personal protective equipment (at a minimum, wear a properly fitting N-95 filtering respirator if working >2 hours per day in the building)

### 4. Control of emission outside the building (Donham *et al.*, 2007)

- Bio filtration (Chen and Hoff, 2009)
- Living environmental buffers (Parker *et al.*, 2012)

## References

- Ackerman, D., 1990. Smell. In: A natural history of the senses. Chapman, London, UK, pp. 5-59.
- Almuhanna, E., Maghirang, R., Murphy, J. and Erickson, L., 2009. Laboratory scale electrostatically assisted wet scrubber for controlling dust in livestock buildings. *Applied Engineering in Agriculture* 25(5): 745-750.
- Andersen, C., Von Essen, S., Smith, L., Spencer, J., Jolie, R. and Donham, K., 2004. Respiratory symptoms and airway obstruction in swine veterinarians: a persistent problem. *American Journal of Industrial Medicine* 46(4): 386-392.
- Avery, R., Wing, S., Marshall, S. and Schiffman, S., 2004. Odour from industrial hog farming operations and mucosal immune function in neighbours. *Archives of Environmental Health* 59: 101-108.
- Banhazi, T., 2009. User-friendly air quality monitoring system. *Applied Engineering in Agriculture* vol. 25(2): 281-290.
- Banhazi, T., Currie, E., Quartararo, M. and Aarnink, A., 2009a. Controlling the concentrations of airborne pollutants in broiler buildings. In: Aland, A. and Madec, F. (eds.) *Sustainable animal production: the challenges and potential developments for professional farming*. Wageningen Academic Publishers, Wageningen, the Netherlands, pp. 347-364.
- Banhazi, T., Currie, E., Reed, S., Lee, I.-B., Aarnink, A., 2009b. Controlling the concentrations of airborne pollutants in piggery buildings. In: Aland, A. and Madec, F. (eds.) *Sustainable animal production: the challenges and potential developments for professional farming*. Wageningen Academic Publishers, Wageningen, the Netherlands, pp. 285-311.

## 25. Challenges to occupational and community health and the environment

- Banhazi, T., Rutley, D. and Pitchford, W., 2008a. Identification of risk factors for sub-optimal housing conditions in Australian piggeries – Part IV: Emission factors and study recommendations. *Journal of Agricultural Safety and Health* 14: 53-69.
- Banhazi, T., Seedorf, J., Rutley, D. and Pitchford, W., 2008b. Identification of risk factors for sub-optimal housing conditions in Australian piggeries – Part II: Airborne pollutants. *Journal of Agricultural Safety and Health* 14: 21-39.
- Beaver, R. and Field, W., 2007. Summary of documented fatalities in livestock manure storage and handling facilities – 1975-2004. *Journal of Agromedicine* 12: 3-23.
- Bell, L., Miller, C. and Schwartz, G., 1992. An olfactory-limbic model of multiple chemical sensitivity syndrome: possible relationships to kindling an affective spectrum disorders. *Biological Psychiatry* 32: 218-242.
- Berkowitz, J., Kraft, D. and Finstein, M., 1974. Persistence of salmonellae in poultry excreta. *Journal of Environmental Quality* 3, 158-161.
- Bitton, G. and Harvey, R., 1992. Transport of pathogens through soils and aquifers, In: Mitchell, R. (ed.) *Environmental microbiology*. Wiley-Liss Inc, New York, NY, USA, pp. 103-124.
- Cambra-Lopez, M., Aarnink, A.J.A., Zhao, Y., Calvet, S. and Torres, A.G., 2010. Airborne particulate matter from livestock production systems: a review of an air pollution problem. *Environmental Pollution* 158(1): 1-17.
- Campagnolo, E., Johnson, K., Karpati, A., Rubin, C., Kolpin, D., Meyer, M., Esteban, J., Currier, R., Smith, K., Thu, K. and McGeehin, M., 2002. Antimicrobial residues in animal waste and water resources proximal to large-scale swine and poultry feeding operations. *Science Total Environment* 299: 89-95.
- Chai, M., Lu, M., Keener, T., Khang, S., Chaiwatpongsakorn, C. and Tisch, J., 2009. Using an improved electrostatic precipitator for poultry dust removal. *Journal of Electrostatics* 67(6): 870-875.
- Chen, L. and Hoff, S., 2009. Mitigating odours from agricultural facilities: a review of literature concerning biofilters. *Applied Engineering in Agriculture* 25(5): 751-766.
- Clark, C., Rylander, R. and Larsson, L., 1983. Airborne bacteria, endotoxin and fungi in dust in poultry and swine confinement buildings. *American Industrial Hygiene Association Journal* 44: 537-541.
- Davidson, L., Fleming, R. and Baum, A., 1987. Chronic stress, catecholamines, and sleep disturbance at Three Mile Island. *Journal of Human Stress* 13: 75-83.
- Djuricic, S., Zlatkovic, M., Babic, D., Gligorijevic, D. and Dlamenc, P., 2001. Sputumcytopathological finding in pig farmers. *Pathology Research and Practice* 197: 145-155.
- Do Pico, G., 1986. Workgroup report on diseases. *American Journal of Industrial Medicine* 10: 261-266.
- Done, S., Chennells, D., Gresham, A., Williamson, S., Hunt, B., Taylor, L., Bland, V., Jones, P., Armstrong, D., White, R., Demmers, T., Teer, N. and Wathes, C., 2005. Clinical and pathological responses of weaned pigs to atmospheric ammonia and dust. *Veterinary Record* 3: 71-80.
- Donham, K., 1986. Hazardous agents in agricultural dusts and methods of evaluation. *American Journal of Industrial Medicine* 10: 205-220.
- Donham, K., 1989. Relationships of air quality and production in intensive swine housing. *Agri-Practice* 10(6): 15-26.
- Donham, K., 1990. Health effects from work in swine confinement buildings. *American Journal of Industrial Medicine* 17: 17-25.
- Donham, K., 1991. Association of environmental contaminants with disease and productivity in swine. *American Journal of Veterinary Research* 52: 1723-1730.
- Donham, K., 1993. Respiratory disease hazards to workers in livestock and poultry confinement structures. *Seminars in Respiratory Infection* 14: 49-59.

- Donham, K., 1995. Agricultural medicine and environmental health: the missing components of the sustainable agricultural movement. In: Human sustainability in agriculture. CRC Press, Inc, Boca Raton, FL, USA, pp. 583-589.
- Donham, K., 2000. The concentration of swine production. effects on swine health, productivity, human health, and the environment. *Veterinary Clinics of North America: Food Animal Practice* 16: 559-597.
- Donham, K., 2010. Community and occupational health concerns in pork production: a review. *Journal of Animal Science* 88: E102-E111.
- Donham, K. and Dauge, R., 1985. Chemical and physical parameters of liquid manure from swine confinement facilities: Health implications for workers, swine, and the environment. *Agricultural Wastes* 14: 97-113.
- Donham, K. and Gustafson, K., 1982. Human occupational hazards from swine confinement. *Annals of the American Conference of Governmental Industrial Hygienists* 2: 137-142.
- Donham, K. and Pependorf, W., 1985. Ambient levels of selected gases inside swine confinement buildings. *American Industrial Hygienic Association Journal* 46: 658-661.
- Donham, K. and Thelin, A., 2006. *Agricultural Medicine: Rural Occupational and Environmental Health for the Health Professions*. Blackwell Publishing. Ames, IA, USA.
- Donham, K. and Thu, K., 1993. Relationships of agricultural and economic policy to the health of farm families, livestock, and the environment. *Journal of the American Veterinary Medical Association* 202(7): 1084-1091.
- Donham, K. and Zejda, J., 1992. Lung dysfunction in animal confinement workers – chairman's report to the Scientific Committee of the Third International Symposium: Issues in health, safety, and agriculture, held in Saskatoon, Saskatchewan, Canada. *Polish Journal of Occupational Medicine and Environmental Health* 5: 277-279.
- Donham, K., Carsons, T. and Adrian, B., 1982a. Carboxyhemoglobin values in swine relative to carbon monoxide exposure: Guidelines to monitor for animal and human health hazards in swine buildings. *American Journal of Veterinary Research* 5: 813-816.
- Donham, K., Cumro, D. and Reynolds, S., 2002. Synergistic effects of dust and ammonia on the occupational health effects of poultry production workers. *Journal of Agromedicine* 8: 57-76.
- Donham, K., Cumro, D., Reynolds, S. and Merchant, J., 2000. Dose-response relationships between occupational aerosol exposures and cross-shift declines of lung function in poultry workers: recommendations for exposure limits. *Journal of Occupational Environmental Medicine* 42: 260-269.
- Donham, K., Haglind, P., Peterson, Y., Rylander, R. and Belin, L., 1989. Environmental and health studies of workers in Swedish swine buildings. *British Journal of Industrial Medicine* 46: 31-37.
- Donham, K., Knapp, L., Monson, R. and Gustafson, K., 1982b. Acute toxic exposure to gases from liquid manure. *Journal of Occupational Medicine* 24: 142-145.
- Donham, K., Merchant, J., Lassise, D., Pependorf, W. and Burmeister, L., 1990. Preventing respiratory disease in swine confinement workers: intervention through applied epidemiology, education, and consultation. *American Journal of Industrial Medicine* 18: 241-262.
- Donham, K., Reynolds, S., Whitten, P., Merchant, J., Burmeister, L. and Pependorf, W., 1995. Respiratory dysfunction in swine production facility workers: dose-response relationships of environmental exposures and pulmonary function. *American Journal of Industrial Medicine* 27: 405-418.
- Donham, K., Rubino, M., Thedell, T. and Kammermeyer, J., 1977. Potential health hazards of workers in swine confinement buildings. *Journal of Occupational Medicine* 19: 383-387.
- Donham, K., Scallon, L. and Pependorf, W., 1986. Characterization of dusts collected from swine confinement buildings. *American Industrial Hygiene Association Journal* 47: 404-410.



## 25. Challenges to occupational and community health and the environment

- Donham, K., Scallon, L., Popendorf, W., Treuhaft, M. and Roberts, R., 1985a. Characterization of dusts collected from swine confinement buildings. *American Industrial Hygiene Association Journal* 46: 658-661.
- Donham, K., Wing, S., Osterberg, D., Flora, J., Hodne C., Thu, K. and Thorne, P., 2007. Community health and socioeconomic issues surrounding concentrated animal feeding operations. *Environmental Health Perspectives* 115: 317-320.
- Donham, K., Yeggy, J. and Dague, R., 1985b. Chemical and physical parameters of liquid manure from swine confinement facilities: health implications for workers, swine, and environment. *Agricultural Wastes* 14: 97-113.
- Donham, K., Yeggy, J. and Dauge, R., 1988. Production rates of toxic gases from liquid manure: Health implications for workers and animals in swine buildings. *Biological Wastes* 24: 161-173.
- Donham, K., Zavala, D. and Merchant, J., 1984. Acute effects of the work environment on pulmonary functions of swine confinement workers. *American Journal of Industrial Medicine* 5: 367-376.
- Ernst, P. and Cormier, Y., 2000. Relative scarcity of asthma and atopy among rural adolescents raised on a farm. *American Journal of Respiratory Critical Care Medicine* 161: 1563-1566.
- Esteban, E., 1998. The confinement animal feeding operation workshop. Centers for Disease Control and Prevention, National Center for Environmental Health, Atlanta, GA, USA.
- Eurostat, 2012. Pig Population. Available at: [http://appsso.eurostat.ec.europa.eu/nui/show.do?dataset=apro\\_mt\\_lspig&lang=en](http://appsso.eurostat.ec.europa.eu/nui/show.do?dataset=apro_mt_lspig&lang=en).
- Fayer, R., 1998. Sources of environmental contamination with *Cryptosporidium*: the role of agriculture. In: *Animal feeding operations and ground water: issues, impacts, and solutions – a conference for the future*, St. Louis, MO, USA.
- Ferguson K., Gjerde, C., Mutel, C., Donham, K., Hradek, C., Johansen, K. and Merchant, J., 1989. An educational intervention program for prevention of occupational illness in agriculture. *Journal of Rural Health* 5: 33-47.
- Follett, R. and Delgado, J., 2002. Nitrogen fate and transport in agricultural systems. *Journal of Soil and Water Conservation* 57: 402-408.
- Fone, D. and Barker, R., 1994. Associations between human and farm animal infections with *Salmonella typhimurium* DT 104 in Herefordshire. *Communicable Disease Report* 4: R136-R140.
- Gjerde, C., Ferguson, K., Mutel, C., Donham, K. and Merchant, J., 1991. Results of an educational intervention to improve the health knowledge, attitudes, and self-reported behaviors of swine confinement workers. *Journal of Rural Health* 7: 278-286.
- Goodrich, P., 1975. Airborne health hazards generated while treating and land disposing waste. *Third International Symposium on Livestock Wastes*, St Joseph, MI, USA, pp. 7-10.
- Hamelin, L., Godbout, S., Theriault, R. and Lemay, S., 2010. Evaluating ammonia emission potential from concrete slat designs for pig housing. *Biosystems Engineering* 105(4): 455-465.
- Hamilton, P. and Helsel, D., 1995. Effects of agriculture on ground-water quality in five regions of the United States. *Ground Water* 33: 217-226.
- Holness, D., O'Blenis, E., Sass-Kortsak, A., Deliger, C. and Nethercott, J., 1987. Respiratory effects and dust exposures in hog confinement farming. *American Journal of Industrial Medicine* 11: 571-580.
- Jacobson, L., 1997. No correlation between hydrogen sulphide and odour. *Minnesota Pork Journal*, Swine Center, University of Minnesota, St. Paul, MN, USA.
- Kiekhaefer, M., 1995. Cross seasonal studies of airborne microbial populations and environment in swine buildings: implications for worker and animal health. *Annals of Agricultural and Environmental Medicine* 2: 37-44.



- Kilburn, K., 1997. Exposure to reduced sulfur gases impairs neurobehavioral function. *Southern Medical Journal* 90: 997-1006.
- Kline, A., Leedom-Larson, K., Donham, K., Schneiders, S. and Rautiainen, R., 2007. Farmer assessment of the Iowa Certified Safe Farm program. *Journal of Agromedicine* 12(3): 33-43.
- Lee, A., 1993. Pathogenicity of *Helicobacter pylori*: a perspective. *Infection and Immunity* 61: 1601-1610.
- Lee, C., Giles, L., Bryden, W., Downing, J., Owens, P., Kirby, A. and Wynn, P., 2005. Performance and endocrine responses of group housed weaner pigs exposed to the air quality of a commercial environment. *Livestock Production Science* 93: 255-262.
- Li, S., Li, H., Xin, H. and Burns, R., 2011. Particulate matter concentrations and emissions of a high-rise layer house in Iowa. *Transactions of the American Society of Agricultural and Biological Engineers* 54: 1093-1101.
- Markowitz, L., Hynes, N., De la Cruz, P., Campos, E., Barbaree, J., Plikaytis, B., Mosier, D. and Kaufmann, A., 1985. Tick-borne tularemia: an outbreak of lymphadenopathy in children. *Journal of the American Medical Association* 254(20): 2922-2925.
- Marmion, B., Ormsbee, R., Kyrkow, M., Wright, J., Worswick, D., Izzo, A., Esterman, A., Feery, B. and Shapiro, R., 1990. Vaccine prophylaxis of abattoir-associated Q fever: eight years experience in Australian abattoirs. *Epidemiology and Infection* 104(2): 275-287.
- Meggs, W., 1997. Hypothesis for induction and propagation of chemical sensitivity based on biopsy studies. *Environmental Health Perspectives* 105: 473-478.
- Meggs, W., Elshick, T. and Metzger, W., 1996. Nasal pathology and ultrastructure in patients with chronic airway inflammation (RADS and RUDS) following an irritant exposure. *Clinical Toxicology* 34: 383-396
- Merchant, J., Naleway, A., Svendsen, E., Kelley, K., Burmeister, L., Stromquist, A., Taylor, C., Thorne, P., Reynolds, S., Sanderson, W. and Chrischilles, E., 2005. Asthma and farm exposures in a cohort of rural Iowa children. *Environmental Health Perspectives* 113: 350-356.
- Merchant, J., Ross, R. and Hodne, C., 2002. Iowa concentrated animal feeding operations air quality study. Iowa City, University of Iowa and Iowa State University, USA.
- Merkel, J., Hazen, T. and Miner, J., 1969. Identification of gases in a confinement swine building atmosphere. *Transactions of the American Society of Agricultural Engineers* 12: 310-315.
- Mustajabegovic, J., Zuskin, E., Schachter, E., Kern, J., Vrcic-Keglevic, M., Vitale, K. and Ebling, Z., 2001. Respiratory findings in livestock farm workers. *Journal of Occupational and Environmental Medicine* 43: 576-584.
- Nilsson, C., 1984. Dust investigations in pig houses, In: *Proceedings of the International Society of Animal Hygiene*. University of Hanover, Hanover, Germany, pp. 31-37.
- Nimmermark S. 2004. Odour influence on well-being and health with specific focus on animal production emissions. *Annals of Agricultural and Environmental Medicine* 11: 163-173.
- Nonnenmann, M., 2004. Vegetable oil sprinkling as a dust reduction method in swine confinements. *Journal of Agricultural Safety and Health* 10(1): 7-15.
- Novotny, V., 1999. Diffuse pollution from agriculture. *Water Science and Technology* 39: 1-13.
- O'Neill, D. and Phillips, V., 1992. A review of the control of odour nuisance from livestock buildings. *Journal of Agricultural Engineering Research* 53: 23-50.
- Osborn, L. and Crapo, R., 1981. Dung lung: a report of toxic exposure to liquid manure. *Annals of Internal Medicine* 95: 312-314.
- O'Shaughnessy, P., Donham, K., Peters, T., Taylor, C., Altmaier, R. and Kelly, K. 2010. A task-based assessment of swine worker exposure to airborne dust. *Journal of Occupational and Environmental Hygiene* 7: 7-13.

## 25. Challenges to occupational and community health and the environment

- O'Shaughnessy, P., Peters, T., Donham, K., Taylor, C., Altmaier, R. and Kelly, K., 2012. Assessment of swine worker exposures to dust and endotoxin during hog load-out and power washing. *Annals of Occupational Hygiene* 56(7): 843-851
- Overcash, M., Humenik, F. and Miner, J., 1983. *Livestock wastes management*, vol I & II. CRC Press Inc, Boca Raton, FL, USA, pp 1-11 (vol I), pp. 165-173 (vol II).
- Parker, D., Malone, G. and Walter, D., 2012. Vegetative environmental buffers and exhaust fan deflectors for reducing downwind odour and VOCs from tunnel-ventilated swine barns. *Transactions of the American Society of Agricultural and Biological Engineers* 55(1): 227-240.
- Payne, H., 1994. Maximum exposure limits for gases and dust in pig buildings. *Air Quality Workshop*, Adelaide, Australia.
- Pew Commission on Industrial Farm Animal Production. 2008. *Putting meat on the table: industrial farm animal production in America*, 35pp.
- Pickrell, J., 1991. Hazards in confinement housing – gases and dusts in confined animal houses for swine, poultry, horses, and humans. *Veterinary and Human Toxicology* 33: 32-39.
- Prior, C., Falk, M. and Frank, A., 2001. Longitudinal changes of sensitization to farming-related antigens among young farmers. *Respiration* 68: 46-50.
- Radon, K., Peters, A., Praml, G., Ehrenstein, V., Schulze, A., Hehl, O. and Nowak, D., 2004. Livestock odours and quality of life of neighbouring residents. *Annals of Agricultural and Environmental Medicine* 11: 59-62.
- Radon, K., Danuser, B., Iversen, M., Monso, E., Weber, C., Hartung, J., Donham, K., Palmgren, U. and Nowak, D., 2002. Air contaminants in different European farming environments. *Annals of Agricultural and Environmental Medicine* 9(1): 41-48.
- Radon, K., Garz, S., Riess, A., Koops, F., Monso, E., Weber, C., Danuser, B., Iversen, M., Opravil, U., Donham, K., Hartung, J., Pedersen, S. and Nowalk, D., 2003. European farmers' project. [Respiratory diseases in European farmers-II. Part of the European farmer' project] *Pneumologie* 5(9): 510-517.
- Radon, K., Schulze, A., Ehrenstein, V., Van Strien, R., Praml, G. and Nowak, D., 2007. Environmental exposure to confined animal feeding operations and respiratory health of neighboring residents. *Epidemiology*. 18: 300-308.
- Reynolds S., Nakatsu, J., Tillery, M., Keefe, T., Mehaffy, J., Thorne, P.S., Donham, K., Nonnenmann, M., Golla, V. and O'Shaughnessy, P., 2009. Field and wind tunnel comparison of four aerosol samplers using agricultural dusts. *Annals of Occupational Hygiene* 53(6): 585-594.
- Reynolds, S., Donham, K., Stookesberry, J., Thorne, P., Subramanian, P., Thu, K. and Whitten, P., 1997. Air quality assessment in the vicinity of swine production facilities. *Journal of Agromedicine* 4: 37-45.
- Reynolds, S., Donham, K., Whitten, P., Merchant, J., Burmeister, L. and Popendorf, W., 1996. Longitudinal evaluation of dose-response relationships for environmental exposures and pulmonary function in swine production workers. *American Journal of Industrial Medicine* 29(1): 33-40.
- Riedler, J., Braun-Fahrlander, C., Eder, W., Schreurer, M., Waser, M., Maisch, S., Carr, D., Schierl, R., Nowak, D. and Von Mutius, E. and the ALEX Study Team, 2001. Exposure to farming in early life and development of asthma and allergy: a cross-sectional survey. *Lancet* 358: 1129-1133.
- Riskowski, G., 1991. Methods for evaluating odour from swine manure. *Applied Engineering in Agriculture* 7: 248-253.
- Ritter, W. and Chirnside, A., 1984. Impact of land use on ground-water quality in southern Delaware. *Ground Water* 22: 38-47.
- Rylander, R., 2004. Organic dust and disease: a continuous research challenge. *American Journal of Industrial Medicine* 46: 323-326.

- Savitz, A. and Weber K. 2006. The triple bottom line: how today's best-run companies are achieving economic, social and environmental success – and how you can too. Josey-Baas, San Francisco, CA, USA.
- Schiffman, S., Miller, E., Suggs, M. and Graham, B., 1995. The effect of environmental odours emanating from commercial swine operations on the mood of nearby residents. *Brain Research Bulletin* 37: 369-375.
- Schwartz, D., Donham, K., Olenchock, S., Pependorf, W., Van Fossen, D., Burmeister, L. and Merchant, J., 1995. Determinants of longitudinal changes in spirometric function among swine confinement operators and farmers. *American Journal of Respiratory Critical Care Medicine* 151: 47-53.
- Schwartz, D., Donham, K., Pependorf, W., Lassise, D., Hunninghake, G. and Merchant, J., 1990. Are work shift changes in lung function predictive of underlying lung disease? In: 1990 World Conference on Lung Health, American Lung Association, American Thoracic Society.
- Seedorf, J., Hartung, J., Schroder, M., Linkert, K., Phillips, V., Holden, M., Sneath, R., Short, J., White, R., Pedersen, S., Takai, H., Johnsen, J., Metz, J., Groot Koerkamp, P., Uenk, G. and Wathes, C., 1998. Concentrations and emissions of airborne endotoxins and microorganisms in livestock buildings in northern Europe. *Journal of Agricultural Engineering Research* 70: 97-109.
- Shusterman, D., 1992. Critical review: the health significance of environmental odour pollution. *Archives of Environmental Health* 47: 76-87.
- Shusterman, D., Balmes, J. and Cone, J., 1988. Behavioral sensitization to irritants/odorants after acute overexposures. *Journal of Occupational and Environmental Medicine* 30: 565-567.
- Sigurdarson, S., O'Shaughnessy, P., Watt, J. and Kline, J., 2004. Experimental human exposure to inhaled grain dust and ammonia: towards a model of concentrated animal feeding operations. *American Journal of Industrial Medicine* 46: 345-348.
- Smit, L., Heederik, D., Doekes, C., Blom, C., Van Zweden I. and Wouters, I. 2008. Exposure-response analysis of allergy and respiratory symptoms in endotoxin-exposed adults. *European Respiratory Journal* 31(6): 1241-1248.
- Smith, R. and Kelly, J., 1996. A comparison of two methods for estimating odour emissions from area sources. In: International Conference on Air Pollution from Agricultural Operations, Kansas City, MO, USA, pp. 263-269.
- Smith, T., Male, M., Harper, A., Kroeger, J., Tinkler, G., Moritz, E., Capuano, A., Herwaldt, L. and Diekema, D., 2009. Methicillin-resistant *Staphylococcus aureus* (MRSA) strain ST398 is present in Midwestern US swine and swine workers. *PLoS ONE* 4: e4258
- Takai, H., Pedersen, S., Johnsen, J., Metz, J., Groot Koerkamp, P., Uenk, G., Phillips, V., Holden, M., Sneath, R., Short, J., White, R., Hartung, J., Seedorf, J., Schroder, M., Linkert, K. and Wathes, C., 1998. Concentrations and emissions of airborne dust in livestock buildings in northern Europe. *Journal of Agricultural Engineering Research* 70: 59-77.
- The Dell, T., Mull, J. and Olenchock, S., 1980. A brief report of gram-negative bacterial endotoxin levels in airborne and settled dusts in animal confinement buildings. *American Journal of Industrial Medicine* 1: 3-7.
- Thelin, A., Tegler, O. and Rylander, R., 1984. Lung reactions during poultry handling related to dust and bacterial endotoxin levels. *European Journal of Respiratory Disease* 65: 266-291.
- Thorne, P., 2007. Environmental health impacts of concentrated animal feeding operations: Anticipating hazards – searching for solutions. *Environmental Health Perspectives* 115: 296-297.
- Thorne, P., Keikhaefer, M. and Donham, K., 1992. Comparison of bioaerosol sampling methods in barns housing swine. *Applied Environmental Microbiology* 58: 2543-2551.

## 25. Challenges to occupational and community health and the environment

- Thu, K. and Durrenberger, P. (eds.), 1998. Pigs, profits, and rural communities. State University of New York, Albany, NY, USA.
- Thu, K., 1995. Understanding the impacts of large-scale swine production. In: Proceedings from an Interdisciplinary Scientific Workshop, Des Moines, IA, USA.
- Thu, K., Donham, K. and Ziegenhorn, R., 1997. A control study of the physical and mental health of residents living near a large-scale swine operation. *Journal of Agricultural Safety and Health* 3: 13-26.
- US EPA, 2002. Animal feeding operations. In: National Pollutant Discharge Elimination System (US Environmental Protection Agency).
- Vos, C. and Zonneveld, J., 1993. Patterns and processes in a landscape under stress: the study area landscapes ecology of a stressed environment. Chapman and Hall, London, UK.
- Walsh, P., Lunney, C. and Casey, K., 1995. Odour impact survey. Milestone Report No. 18, Meat Research Corporation Project No. DAQ-079; Department of Primary Industries, Beef Industry Group; Toowoomba, Qld, Australia.
- Will, L. and Diesch, S., 1972. Leptospire in animal waste treatment--animal health problem? Proceedings, 76<sup>th</sup> Annual Meeting of the US Animal Health Association, pp. 138-149.
- Wing, S. and Wolf, S., 2000. Intensive livestock operations, health and quality of life among East North Carolina residents. *Environmental Health Perspectives* 108(3): 233-238.
- Wing, S., Horton, A., Marshall, S., Thu, K., Tajik, M., Schinasi, L. and Schiffman, S., 2008. Air pollution and odour in communities near industrial swine operations. *Environmental Health Perspectives* 116: 1362-1368.
- World Health Organization, 1972. Health hazards of the human environment. WHO, Geneva, Switzerland.
- Wossink, A., 2008. The failure of marketable permit systems and uncertainty of environmental policy: a switching regime model applied to the Dutch phosphate quota program. American Agricultural Economic Association, Tampa, FL, USA.



## Keyword index

### A

- accelerometers – 421
- actinomyces – 165
- ADG – 185, 305
  - effect of stocking density – 310
  - effect of stocking rate – 309
  - factors affecting ~ – 307
  - of pigs – 309
- aerobic
  - decomposition – 166
  - microorganisms – 165
- aerosol – 465
- age segregated rearing – *See*: ASR
- agonistic behaviour – 42
- AIAO – 298, 309, 342, 345, 355, 383
- airborne bacteria, measurement – 287
- airborne particles
  - in piggery – 302
  - in poultry buildings – 282
  - measurement – 286, 300
  - reduction by oil-spraying – 288, 290
- airborne pollutants – 315
  - health effects on horses – 282
  - in piggery buildings – 297
  - measurement – 320
  - reduction – 310
  - synergistic effect – 317
- air quality index – *See*: AQI
- air speed – 251
- air velocity – 217
- air volume – 248
- airway inflammation in pigs – 317
- all in/all out – *See*: AIAO
- allogrooming – 42
- ammonia
  - avoidance behaviour – 317
  - concentration in piggery – 302
  - emission – 267
  - emission and manure removal – 268
  - emission and temperature – 269
  - emission and ventilation – 270
  - emission from soiled manure – 172
  - exposure to ~ – 262
  - from bedding – 133
  - from manure – 162
  - from poultry manure – 170
  - from solid manure – 169, 174
  - health effects on pigs – 262
  - health effects on poultry – 263
  - reduction by oil-spraying – 291
  - TLV for poultry – 318
- AMS – 38
- ancient Egypt – 22
- animal feeding operations – *See*: AFO
- Animal Needs Index – 59
- animal welfare analysis network –  
*See*: AWALAN
- anoxia in piglets during birth – 98
- antibiotics pollution – 472
- AQI – 320
- aquarium heaters – 156
- asbestos – 252
- ASR – 298
- asthma – 462
- atrophic rhinitis – 321
- automated milking systems – *See*: AMS
- automation on dairy farms – 393
- average daily gain – *See*: ADG
- AWALAN – 401

### B

- back arch of cows – 420, 426
- battery cages – 168, 432
- bedding – 77
  - and pig health – 87
  - bark – 79
  - compost – 79
  - for horses – 129
  - material – 125
  - sand – 79
  - sawdust – 79
  - straw – 45, 78
  - straw in cubicles – 78
  - straw-manure-mattresses – 78
  - treatment of ~ material – 284
  - wood chips – 79

## Index

- behaviour
    - diurnal ~ of laying hens – 437
    - excretory ~ of pigs – 377
    - of female rabbits – 128
  - behavioural needs – 31
  - bio-aerosol – 297
  - biofilms – 348
  - biofilter – 270
    - packing material – 271
  - biosecurity – 332
  - bloat – 46
  - boar taint – 341
  - body temperature of cows – 396
  - botanical composition
    - goats diet – 118
    - horse diet – 116
    - sheep diet – 118
  - botulism – 123
  - bovine respiratory disease – 196
  - Brachyspira hyodysenteriae – 340
  - broiler – 223
  - Bronze Age – 22
  - BSE – 122
  - bursitis – 87
- C**
- CAFO – 457
  - Campylobacter jejuni – 344
  - cannibalism – 432
  - Canola oil – 285
  - carbon – 163
  - carbon dioxide – 267
  - carpus lesions – 85
  - cattle diet, botanical composition – 116
  - cereal grains preservation – 123
  - CF – 383
  - cfu – 316
  - classical swine fever – *See: CSF*
  - claw disorders – 338
  - claw-floor contact – 82
  - claw health – 81
  - claw lesions in cows – 420
  - cleaning – 332
    - efficiency – 356
    - methods – 372
    - operations – 345
  - cleaning-disinfection, efficacy – 348
  - cleanliness – 332, 379
    - of bulls – 345
    - of cattle – 344
    - programs to improve ~ – 339
  - climate
    - control – 212
    - (indoor) in cow houses – 399
  - cold stress in cows – 40
  - colony forming units – 358 – *See: cfu*
  - colostrum – 117
  - composting – 136
    - optimum C/N ratio – 136
    - phases – 165
  - concrete flooring – 125
  - condition score – 196
  - confined animal feeding operation –
    - See: CAFO*
  - continuous flow – *See: CF*
  - cooling – 228
  - copper intoxication in sheep – 124
  - coughing sound of pigs – 409
  - cough sound
    - amplitude – 410
    - localization – 415
    - of humans – 408
    - of pigs – 407
    - recognition – 411
  - cow comfort – 55
    - score – 63
    - score system – 58
  - cow dirtiness – 130
  - creep – 102
  - crop rotation – 27
  - crushing of piglets – 97, 99
  - CSF – 332
  - cubicle refusal – 130
  - cubicles – 38
    - width – 41
- D**
- data acquisition parameters
    - for cow welfare – 395
  - deed tossing – 39

- deep litter – 84, 162, 165, 167
    - management – 177
    - turning – 168
  - deep straw bedding – 38, 86
  - degreaser – 362, 365, 372
  - dermatitis – 44, 338
    - in chickens – 88
  - disinfectants – 356
  - disinfection – 332, 346
  - docking – 339
  - domestication – 32
  - drinking habits
    - of calves – 117
    - of cattle – 117
    - of horses – 116
    - of sheep – 118
  - drinking water
    - factors affecting ~ temperature – 151
    - reservoirs – 155
    - seasonal variation of ~ temperature – 153
    - temperature of ~ for pigs – 148
  - dung
    - foraging – 339
    - heap – 134
  - dunging area
    - in farrowing pen – 103
    - of pigs – 377
  - dunging behaviour
    - interventions – 387
    - patterns in pigpen – 384
  - dust – 263, 281, 346, 458, 465
    - and activity of pigs – 265, 272
    - and air cleaning – 273
    - and humidity – 272
    - and laying hens – 272
    - and ventilation – 272
    - exposure limits – 463
    - from swine production – 461
    - health effects on humans – 264
    - health effects on pigs – 264
    - removal with oil-water mixture – 274
    - TLV for poultry – 318
  - dust bathing – 128
- E**
- electronic controllers – 185
  - emissions – 267, 282
    - extra-toxic effects – 467
  - enclosed operations – 456
  - endophyte-infected grass – 196
  - endotoxin – 264, 317, 458
  - enteric disorders in pigs – 340
  - environmental
    - exposure – 473
    - issues – 456
    - pollution – 30, 47
    - stress syndrome – 469
  - eradication policy – 28
  - Escherichia coli – 120, 335
  - evaporative cooler – 230
  - excessive regulation – 456
  - exercise – 43
  - exploratory behaviour – 86
    - of pigs – 127
  - exposure of workers – 459
  - extra-toxic effects – 467
- F**
- faecal material – 356
  - fallow land – 25
  - farm yard manure – *See: FYM*
  - farrowing crate – 93
    - behaviour of sows – 95
    - dimensions – 95
    - health effects – 94
    - room for piglets – 96
  - farrowing pens – 84, 102
    - design recommendations – 104
  - farrowing rail – 100
  - fattening pigs – 86
  - FE – 185
  - feather pecking – 132, 432, 437
  - feed
    - efficiency – *See: FE*
    - intake and heat production – 196
    - selection by cows – 40
  - feeders in farrowing pens – 103
  - feeding behaviour of laying hens – 435
  - fertilisation of cows – 47



## Index

fish ponds – 171  
flaming to clean floors – 362, 372  
flies – 135  
floor – 75  
– abrasive surface – 81  
– elastic cover – 82  
– epoxy resin cover – 83  
– friction – 82  
– grooves – 82  
– hardness – 45  
– hygiene – 81  
– properties – 76  
– requirements – 76  
– slatted – 77, 81  
– zonation in sow pens – 342  
floor heating in farrowing pens – 102, 103  
FMD – 332  
– transmission by farmer – 333  
food  
– expenditure – 30  
– safety – 30  
foot and mouth disease – *See*: FMD  
foot lesions of finishing pigs – 86  
foot pad dermatitis – 132  
foot rot – 131  
forage supplements – 46  
free range  
– conditions – 94  
– pigs – 132  
fungi – 165  
FYM – 162

**G**  
gait – 397  
– aberrations – 420  
– analysis – 420  
gases from manure – 135, 459, 465  
– exposure limits – 463  
gas trap – 266  
GHG – 162, 174, 178, 267  
 $\beta$ -glucans – 324, 458  
grain diet of feedlot cattle – 197  
grazing – 39  
– cattle – 116  
– horse – 115

– rabbit – 119  
– sheep – 117  
greenhouse gases – *See*: GHG  
growth rate of pigs – 298

## H

haemolytic ureamic syndrome – *See*: HUS  
hard flooring – 131  
head flies – 45  
health  
– occupational ~ of pork producers – 457  
– of dairy cows – 393  
– records – 58  
– status – 55, 58  
– WHO definition of human ~ – 457  
heat exchange  
– latent – 215  
– sensible – 215  
heat exchangers – 464  
heat increment – 197  
heat load  
– from moving of cattle – 201  
– index – *See*: HLI  
– via thermal radiation – 227  
heat loss of broiler chickens – 219  
heat production – 212  
– of pigs – 221  
heat stress  
– control – 228  
– control in dairy housing – 226  
– economic losses – 189  
– in cattle – 189  
– indicator – 219  
– in heifers – 195  
– night-time recovery – 191  
– of cows – 40  
– of sows – 94, 103, 216  
– susceptibility – 193  
heat tolerance – 195  
heat transfer  
– by conduction – 216  
– by convection – 216  
– by radiation – 217  
– from pigs – 224  
– latent – 219

- heat treatment – 367
  - heat wave – 190
  - Hilbert Transform – 410
  - history
    - of animal production – 27
    - of farms – 23
  - HLI – 192
  - hock lesions – 80, 126, 130
  - hoof imprint – 421
  - horse – 282
  - houseflies – 343
  - housing systems – 185
  - humidity – 191, 251
  - HUS – 120
  - hybrid ventilation – 213
    - in pig houses – 227
  - hydrofoamers – 347
  - hydrogen sulphide – 139, 266, 460
    - exposure prevention – 464
  - hygiene – 356
    - definition of ~ – 331
    - in pig houses – 340
  - hygiene-pavers – 357
  - hypothermia of piglets – 100, 102
- I**
- image processing – 421, 424
  - incandescent light – 432
  - incineration of solid manure – 178
  - indoor foraging – 39
  - infectious
    - agents – 462
    - diseases – 47
  - inhalable dust – 458
  - insulated roofs – 252
  - insulating material – 246
  - intensification – 28, 30, 38
  - intersucking – 39
- K**
- keel bone deviation – 437
  - Klebsiella – 130, 338
- L**
- lactating sows – 84
  - lameness – 44, 81, 95, 130, 338, 397, 419
    - automatic detection – 401
    - classification in cows – 427
    - indicators – 424
    - observer score – 423
  - laminitis – 41
  - latent heat of vaporization – 219
  - lateral recumbence – 84
  - LBI – 319
    - in pig and chicken houses – 322
  - LCT – 132, 185, 237
  - leg disorder symptoms – 397
  - leucocytosis – 462
  - light
    - daylight inlets in layer houses – 432
    - distribution in pig pens – 445
    - effect on hen behaviour – 433
    - effects on pig behaviour – 442
    - EU standards for pig houses – 441
    - perception by birds – 432
    - wavelength – 431
  - lighting environment
    - of laying hens – 431
  - light intensity – 431
    - and hen movement – 433
    - and pig behaviour – 442
    - in pig houses – 441, 445
  - lignified biomass – 165
  - lime – 172
  - lime solution as cleaning agent – 370
  - liquid manure
    - fertilization of pasture with ~ – 124
    - solids content of ~ – 135
  - liquid manure handling – 135
    - hygienic aspects – 138
  - Listeria – 122
  - litter management for poultry – 87
  - litter moisture control – 233
  - livestock burden index – *See*: LBI
  - locomotion – 43, 397, 420
    - monitoring – 398
    - sensors – 421
  - locomotor problems – 45
  - lower critical temperature – *See*: LCT
  - luxmetric probe – 444

## Index

- lying area – 44, 76
  - of cattle – 126
  - of pigs – 378
- lying time – 59
  - for cows – 44

## M

- malodour – 135
- management
  - guidelines for thermal control – 253
  - to reduce dust and gases – 463
  - to reduce heat stress in cattle – 196
- manure – 161
  - bacterial composition – 373
  - cooling – 269
  - excessive application – 471
  - handling – 133
  - health risks of application – 138
  - separators – 135
  - solid poultry ~ – 163
  - transport – 162
- mastitis – 45, 129, 337, 396
- maternal behaviour of sows – 100
- mats – 80
- mattresses – 80
- meal – 123
- mechanical ventilation – 213
- melengestrol actate – 195
- meningitis – 122
- methane emission – 171, 174
  - from manure application – 176
- microbial contamination – 471
- Middle Ages – 24
  - housing for farrowing sows – 25
  - meat consumption – 25
  - swine herds – 25
- milking parlours – 38
- milk quality estimation – 396
- mineral imbalances – 46
- monitoring of air quality – 300
- multi-gas monitoring – 286, 301
- mycotoxins – 123

## N

- natural behaviour of dairy cows – 38

- natural light in pig houses – 447
- natural ventilation – 169, 210, 212
- Neolithic revolution – 21
- nest building – 94
- nesting behaviour of sows – 101
- nitrate – 470
- nitrification-denitrification – 168
- nitrite – 46, 470
- nitrogen – 163
  - cycle – 470
  - deposition – 267
  - leaching – 172
- nitrous oxide
  - emission – 173
  - from animal houses – 170
  - from manure application – 175
  - from solid manure – 164
- noxious gases – 41

## O

- odour – 162, 199, 266, 465
  - health effects – 466
  - health symptoms – 468
- oestrus behaviour – 44, 48
- oil-impregnated bedding – 290
- oil spraying system – 283
- olfactory nerve – 468
- organic matter transformation – 164
- ovarian activity – 47
- oxytocin – 98

## P

- parasites – 46
- Parvovirus – 334
- pasture rotation – 124
- pathogens – 47, 316
  - recycling through feces – 340
  - survival in manure – 137, 334, 471
  - survival in soil – 138
  - transportation – 334
- peat – 170
- pen design – 100
- pen fouling by pigs – 378
- pen hygiene – 381
  - and wetted floors – 384

perching – 435, 437  
 phosphorus – 162, 471  
 pig behaviour – 128  
 piggery buildings in Australia – 238  
 piglet mortality – 94  
   – and farrowing crates – 98  
   – and litter size – 98  
 piglets – 85  
 pipe diameter – 155  
 play chains – 386  
 pleuropneumonia in pigs – 408  
 PLF – 394  
 posture  
   – abnormal ~ of sows – 131  
 precision animal management – 202  
 precision livestock farming – *See*: PLF  
 preening – 128  
 pressure washing – 362  
   – and aerosols – 365  
 prions – 122  
 pulmonary function studies – 462

**R**

rebound behaviour – 43  
 renewable energy – 162  
 respiration rate – 191  
 respirators – 464  
 respiratory diseases – 262, 281, 298, 316  
   – diagnostic tool – 416  
   – health hazard – 458  
   – in pigs – 355, 407  
   – monitoring – 412  
   – symptoms in community residents – 467  
   – symptoms of workers – 461  
 ridge ventilation – 246  
 ridge vents – 252  
 rinderpest – 28  
 rodents – 252, 343  
 Roman Age  
   – housing for pregnant sows – 24  
   – poultry houses – 24  
 roof pitch – 246  
 roosting – 432  
 rooting – 118, 127  
 roughage – 117

rubber mats – 78  
 rumination – 40, 397  
   – of cattle – 116  
   – of sheep – 117  
 runoff – 470

**S**

Salmonella – 121, 139, 343  
 sandwich panel buildings – 252  
 sanitation – 356  
 sanitation break – 343  
 savaging – 99  
 sawdust – 129, 386  
   – oil impregnated ~ – 380  
 SCC – 334, 338  
   – in milk – 396  
 scraped floors – 84  
 scrapers – 134, 339  
   – for solid manure – 167  
 scratching – 119  
 segregation – 332  
 separation of urine – 136  
 shade – 199  
 sheep liver fluke – 23  
 silage – 124  
 skin surface area – 230  
 skin wetness – 234, 251  
 slatted floor – 84  
   – and risk of infection – 87  
   – for pigs – 85  
   – in pig houses – 341  
   – partially ~ for pigs – 377  
   – with metal studs – 383  
 slippery floors – 44  
 slip resistance – 82  
 slurry – 163  
   – from poultry manure – 170  
 soil temperature – 199  
 solar radiation – 191, 198  
 solid manure – 162  
   – emissions from ~ – 168  
   – handling – 134  
   – hygienic aspects – 137  
   – storage – 171  
   – turning – 171

## Index

somatic cell count – *See*: SCC  
sound analysis in piggeries – 408  
sow welfare – 95  
specialisation – 30  
spreading contagious agents – 137  
sprinkling – 233  
– cattle – 199  
starvation of piglets – 100  
statistical analysis – 150  
stereotypies – 94, 127  
stillborn piglets – 98  
stocking density in piggeries – 253, 414  
stocking rate and pen fouling – 384  
straw – 126, 127  
– emission reduction by ~ – 169  
– in solid manure – 167  
stress  
– in piggeries – 311  
– response to crating – 95  
sustainability – 31, 456  
sustainable livestock production – 30  
synchronised behaviour – 41

## T

tail biting – 127, 131  
TAN – 164, 179  
temperature – 308  
– air ~ in piggery – 156, 241  
– and pen fouling – 382  
– measurement – 239  
– pig drinking water – 151  
– sensors – 148  
– variation in piggeries – 242  
temperature-humidity index – *See*: THI  
thermal comfort – 209  
– of immature animals – 220  
thermal control  
– factors – 244  
– model – 244  
– of Australian piggeries – 252  
– of piggery buildig – 250  
thermal deficiency – 250  
thermal environment of pigs – 378  
thermal needs – 185  
– of farrowing environment – 102

thermal shield – 227  
thermoneutral zone – 185 – *See*: TNZ  
THI – 190, 323  
threshold limit values – *See*: TLVs  
thrush – 129  
tie stalls – 38  
TLVs – 316, 321  
TNZ of pigs – 237  
tongue rolling – 39  
total ammoniacal nitrogen – *See*: TAN  
triple bottom line – 456  
tunnel designs – 224  
tunnel ventilated barn – 223, 224  
turkeys – 120, 133

## U

UCT – 185, 237  
udder health – 331  
udder hygiene – 337  
upper critical temperature – *See*: UCT  
ureic acid hydrolysis – 170  
urinating habits of horses – 126  
urine – 268  
– fertilization with ~ – 124  
– pH – 137  
urogenital tract infections in sows – 340

## V

vacuum activities – 127  
veal calves – 344  
ventilation – 200, 463  
– designed by King – 210  
– designed by Rutherford – 211  
– dust and gas concentrations – 459  
– history – 210  
video recordings – 425  
vigilance – 41

## W

wallowing – 238, 339  
warm drinking water – 156  
washing – 346  
water contaminants – 470  
water hygiene standards – 124  
water intake

- of beef cattle - 198
- of sows - 157
- water pipes - 154
- water pressure - 154
- water requirement
  - of chickens - 119
  - of domestic pigs - 119
  - of rabbits - 119
- water reservoirs - 155
- water temperature - 147
  - on Australian pig farms - 149
  - on cattle feedlots - 198
- weed seeds - 172
- welfare - 30
  - assessment of cow ~ - 393
  - automated ~ evaluation - 394
  - monitoring - 398
  - of dairy cows - 393
  - of laying hens - 432
  - quality assessment - 56
  - status of cows - 60
- well-being - 209
- wind speed - 191

## Y

- Young Identification Criterion - 415











